

Cleaning technology · Municipal technology

Hako
Clean ahead



Operating Manual **Citymaster 650 (147015)**

Issue: 02.2020

Part number: 88-10-3206-4001-02

Introduction

Foreword

Dear customer,

We are certain that the excellent qualities of the vehicle will justify the faith you have shown in us by your purchase.

To guarantee you safe working with the vehicle, please read the Safety Notes chapter before putting it into service.

Your own safety, as well as the safety of others, depends essentially on your ability to control the vehicle. Please read this **original operating manual** before you use the vehicle for the first time, act accordingly and keep these instructions for future reference or subsequent users. The operating manual (to ISO 3600) contains all important information for operation, maintenance and care. We have provided the places in this operating manual concerning your safety with a danger pictogram. Your authorised Hako dealer is available at all times to answer further questions about the vehicle or the operating manual.

We would expressly advise you that no legal claims may be asserted based on the contents of this operating manual. In the case of necessary repair work, please make sure that only original spare parts are used. Spare parts must be original spare parts to guarantee safety. We reserve the right to make changes in the interests of further technical development.

Hako GmbH
23843 Bad Oldesloe, Germany
Hamburger Str. 209-239
Phone +49 4531 806-0

Issue:

Index	Part number	Valid as from:	FIN
0	88-10-3206-4001-02	03.2020	WHW14701500001200

Applications

The Citymaster 650 is a multi-purpose machine for commercial and municipal use throughout the year. The Citymaster 650 can be used as vacuum sweeping system, lawn mowing system, sweeping system, snow clearing system and transport system. The basic vehicle **Fig. 1-A** without attachments is described in chapter 1 to 5. The following attachments are described in chapter 6:

- Vacuum sweeping system with the sweeping unit, suction mouth, dirt hopper and trolley **Fig. 1-B**
- Lawn mowing system with the mower **Fig. 1-C**
- Sweeping system with front sweeping machine **Fig. 1-D**
- Snow clearing system with the front sweeping machine or a snow blade **Fig. 1-E**. The salt and grit spreader **Fig. 1-F** can be used for spreading.

The loading platform **Fig. 1-G** is used for holding salt and grit.

- Transport system with the loading platform or with trailer **Fig. 1-H**.

Your authorised Hako dealer is available to you at all times to answer questions on further applications.



Fig. 1:

Vehicle data

Your vehicle is described clearly by the following data. Please always quote these data in correspondence or when making a telephone query to your authorised Hako dealer or our company.

- Vehicle type: _____
- Chassis number: _____
- Engine number: _____
- Start-up on: _____

Please enter the data applicable to your vehicle in the list above. The data are immediately available in the case of enquiries or spare parts orders.

Your nearest authorised Hako dealer

- Address: _____

- Telephone: _____

Intended use

The Citymaster 650 is a multi-purpose machine intended for commercial and municipal use throughout the year and with the attachments approved by Hako it is suitable for use for mowing and sweeping and for snow clearing. Any use extending beyond this is not intended use. The manufacturer is not liable for any damage resulting from this and the user alone bears the risk. Intended use also includes compliance with the operating, maintenance and servicing conditions specified by the manufacturer. The vehicle may be used, maintained and repaired only by persons who are familiar with this work and instructed about the dangers. The vehicle and its attachments correspond by virtue of their design and construction as well as in the version distributed by us to the usual health and safety requirements of the EC Directives (see Declaration of Conformity and CoC documents). These documents lose their validity in the event of a modification not authorised by us. The manufacturer is not deemed liable for any damage resulting from unauthorised modifications to the machine.

Notes on warranty

The terms defined in the purchase agreement apply. Claims for compensation in relation to damage are excluded from the terms of the warranty when the damage is the result of the failure to observe rules concerning servicing and maintenance. Maintenance work must be carried out by authorised Hako dealers and confirmed in the "Maintenance Report", which serves as a warranty logbook. The following are excluded from the terms of warranty: wear and tear through overuse, defective fuses, improper handling and use and unauthorised modifications. Claims under the terms of the warranty are also annulled when damage occurs to the vehicle resulting from the use of parts or accessories not explicitly approved of by us or from failure to observe maintenance rules.

Acceptance of the vehicle

Inspect the vehicle immediately on delivery for signs of transport damage. You will be compensated if the damage is immediately confirmed by the haulage contractor and the damage report is sent to our authorised Hako dealer together with the consignment note.

Conditions for approval

The Citymaster 650 is a multi-purpose machine (tractor for use in agriculture or forestry) in terms of the EU Regulation 167/2013. The manufacturer provides an EC Certificate of Conformity and an EC Declaration of Conformity. Based on the EC Certificate of Conformity, the local licensing authorities will produce the registration certificate part 2 (vehicle registration) and part 1 (vehicle registration). For use on public roads, paths and areas the Citymaster 650 has to be licensed and display an official license plate. In accordance with the StVZO, in Germany the vehicle must carry a first aid kit, warning triangle and the vehicle type approval when used on public roads, paths and pedestrian precincts. In Germany the Citymaster 650 is subject to regular general inspection according to § 29 StVZO (every 24 months).



Warning

If any modifications or additions are made to the Citymaster 650, which affect the contents and are not contained in the registration certificate, it will become void. In consequence the insurance cover and the vehicle tax will also become void.

To acquire a new registration certificate, the vehicle must be presented to an officially accepted expert to produce a new report. The modifications have to be included in the registration certificate by the registration authorities. In the EC Declaration of Conformity the manufacturer declares that the attachments approved by Hako adhere to the rulings in the EC Directive 2006/42/EC.

In other countries, the corresponding national regulations must be complied with.

Driving license

According to the driving license law in Germany, the Citymaster 650 may be driven as a multi-purpose machine (tractor) by drivers with driving license class B. Driving license class B includes vehicle class L (certain agricultural machinery).

In other countries, the corresponding national regulations must be complied with.

Equipment

According to § 53 StVZO the following equipment has to be kept with the vehicle in the Federal Republic of Germany (not included in the scope of supply):

- 1 warning triangle of approved type
- 1 warning light of approved type
- 1 warning vest
- 1 first aid kit corresponding at least to the requirements of DIN 13164, Sheet 1 standard. In other countries, the corresponding national regulations must be complied with.

Required documents

Within the Federal Republic of Germany, the following documents must always be available:

- Approval certificate (Part I) of the vehicle
- Valid driving license of the driver
- Operating manual (kept in the left-hand operating console)

In other countries, the corresponding national regulations must be complied with.

Vehicle inspection

- All occupational accident insurance schemes in the Federal Republic of Germany require a **safety inspection** of your vehicle according to BGV D 29, which must be made at least once annually by an expert. An inspection label should be attached to the vehicle in addition so that the driver knows when the next expert inspection is due.
- According to § 29 StVZO of the Federal Republic of Germany, a general inspection (**HU**) must be made regularly:
 - For vehicles of less than / equal to 3.5 t permitted overall weight every 24 months (for vehicles which are hired commercially without provision of a driver, 12 months apply).
 - For vehicles of more than 3.5 t permitted overall weight every 12 months.

In other countries, the corresponding national regulations must be complied with.

	Introduction	2
	Foreword	2
	Applications	3
	Vehicle data	4
	Intended use	5
	Notes on warranty	5
	Acceptance of the vehicle	5
	Conditions for approval	5
	Driving license	6
	Equipment	6
	Required documents	6
	Vehicle inspection	6
1	Safety Instructions	11
1.1	Marking of warning and danger symbols	11
1.2	General safety instructions	12
1.3	Operating safety instructions	12
1.4	Safety instructions for attachments	14
1.5	Information about special risks	16
1.6	Safety instructions for maintenance and servicing	17
1.7	Environmental protection instructions	19
1.8	Shutting down and disposal	20
1.9	Labels on the vehicle	21
2	Use.....	25
2.1	Overviews	25
2.1.1	Front view	26
2.1.2	Rear view	28
2.1.3	Driver's cab	30
2.2	Multifunction display	35
2.2.1	Start screen	35
2.2.2	Menu guidance	35
2.2.3	Menu structure	36
2.2.4	Normal view	37
2.2.5	Working menu (A menu)	38
2.2.6	Operating menu (B menu)	40
2.2.7	Configuration menu (C menu)	42
2.2.8	Warning and information symbols	49
2.3	Controls in the driver's cab	53
2.3.1	Steering column control panel	53
2.3.2	Comfort steering wheel (optional)	56
2.3.3	Left-hand control panel	59
2.3.4	Right-hand control panel	59
2.3.5	Arm rest control panel	62
2.3.6	Roof control panel	63
2.3.7	Accelerator pedal	64
2.3.8	Coarse material flap	64
2.3.9	Brake system	65
2.3.10	Driver's seat	66
2.3.11	Seat belt	68
2.3.12	Cab heating	69
2.3.13	Air conditioning system	70
2.3.14	Doors	71
2.4	Operating elements on the vehicle	72

2.4.1	Auxiliary tool	72
2.4.2	Ball cock circulating water	72
2.4.3	Front tool carrier	73
2.4.4	Connections for front attachments	76
2.4.5	Connections for rear attachments	77
3	Operation	78
3.1	Instruction	78
3.1.1	Climbing up and down	78
3.2	Before start-up of the vehicle	79
3.2.1	Check-list – Before start-up of the vehicle	80
3.3	Starting and driving the vehicle	83
3.3.1	Starting and driving the vehicle	84
3.3.2	Diesel particle filter	87
3.3.3	Troubleshooting	89
3.4	Shutting down the vehicle	90
3.4.1	Shutting down after the end of work	90
3.4.2	Shutting down in work breaks	90
3.4.3	Shutting down on occurrence of faults	90
3.5	Transporting and towing the vehicle	91
3.5.1	Transporting the vehicle	91
3.5.2	Towing the vehicle	92
3.6	Working with attachments	93
3.6.1	Ballast	94
4	Technical data	97
5	Maintenance and Servicing	100
5.1	Maintenance plan	101
5.2	Panelling and covers	102
5.2.1	Removing the engine cover	102
5.2.2	Opening the side panelling on the left and right	102
5.2.3	Removing radiator cover	102
5.3	Engine	103
5.3.1	Checking the engine oil level	103
5.4	Fuel system	104
5.4.1	Emptying the water trap	104
5.5	Cooling system	105
5.5.1	Cleaning the cooling system	105
5.5.2	Checking the coolant level	106
5.6	Air filter	107
5.6.1	Checking the air filter	107
5.6.2	Cyclone separator and dust ejection valve	107
5.6.3	Cleaning/changing the air filter	108
5.6.4	Changing the safety cartridge	108
5.7	Hydraulic system	109
5.7.1	Important information for using BIO OIL	110
5.7.2	Checking the hydraulic oil level	111
5.8	Driver's cab	112
5.8.1	Changing the cab air filter	112
5.9	Wheels	113
5.9.1	Tyre changing	113
5.10	Electrical system	114







5.10.1	Lamps	114
5.10.2	Fuses and relays	116
5.10.3	Battery	119
5.11	Lubrication plan	121
5.12	Cleaning the vehicle	122
5.12.1	General notes	122
6	Attachments and Options.....	124
6.1	Vacuum sweeping system	125
6.1.1	Labels on the unit	126
6.1.2	Vacuum sweeping system safety instructions	126
6.1.3	Mounting	127
	Mounting the suction mouth	127
	Mounting the sweeping unit	128
	Mounting the dirt hopper.	130
6.1.4	Operation	133
	Check-list – Before start-up of the vacuum sweeping system	133
	Checklist – Vacuum sweeping	135
	Checklist – Settings for vacuum sweeping	141
	Check-list – Cleaning the vacuum sweeping system	143
6.1.5	Technical data	146
6.1.6	Maintenance	148
	Maintenance plan	148
	Inserting the safety strut	149
	Checking the rotating brushes	149
	Checking the rotating brush pressure	150
	Checking the sweeping level	150
	Checking the suction mouth sealing strips	151
	Checking the suction duct seal	152
	Lubrication points	152
6.1.7	Troubleshooting	153
6.1.8	Accessories	153
6.2	Lawn mowing system	154
6.2.1	Labels on the unit	155
6.2.2	Mowing system safety instructions	155
6.2.3	Mounting	156
	Mounting the mower	156
6.2.4	Operation	157
	Check-list – Before start-up of the mowing system	157
	Checklist – Mowing	158
6.2.5	Technical data	159
6.2.6	Maintenance	160
	Maintenance plan	160
	Changing mowing blades	161
	Changing the V-belt	161
	Cleaning the mower	161
	Cleaning the suction nozzle	161
	Lubrication points	161
6.2.7	Troubleshooting	162
6.2.8	Accessories	162
6.3	Sweeping system	163
6.3.1	Labels on the unit	164
6.3.2	Sweeping system safety instructions	164
6.3.3	Mounting	165
	Mounting the front sweeping machine	165

6.3.4	Operation	166
	Check-list – Before start-up of the sweeping system	166
	Checklist – Sweeping	167
6.3.5	Technical data	169
6.3.6	Maintenance	169
	Maintenance plan	169
	Changing the sweeping roller	169
	Checking the sweeping level	169
	Checking the V-belt tension	170
	Changing the gearbox oil	170
	Lubrication points	171
6.3.7	Troubleshooting	171
6.3.8	Accessories	171
6.4	Snow clearing system	172
6.4.1	Labels on the unit	173
6.4.2	Snow clearing system safety instructions	173
6.4.3	Mounting	174
	Mounting the snow blade	174
	Mounting the loading platform	175
	Mounting the spreader	178
6.4.4	Operation	179
	Checklist – Before start-up of the snow clearing system	179
	Check-list – Snow clearing	180
6.4.5	Technical data	182
6.4.6	Maintenance	182
6.4.7	Accessories	182
6.5	Transport system	183
6.5.1	Labels on the unit	184
6.5.2	Safety instructions	184
6.5.3	Mounting	184
	Mounting the trailer hitch plate (optional)	184
	Mounting the jaw coupling (optional)	185
	Mounting the ball head coupling (optional)	185
6.5.4	Operation	186
	Coupling the trailer	186
	Uncoupling the trailer	186
	Starting transport	186
6.5.5	Technical data	187
6.5.6	Maintenance	187
6.5.7	Accessories	187
6.6	Options	188
	EC conformity declaration.....	189

1 Safety Instructions

1.1 Marking of warning and danger symbols

Important tasks concerning the safety of the operator and vehicle are named as follows in this operating manual and emphasised by symbols:

	<p>Danger Indication of a direct danger with high risk, in which death or severe physical injury can occur if it is not avoided.</p>
	<p>Warning Indication of a possible danger with average risk, in which death or severe physical injury can occur if it is not avoided.</p>
	<p>Caution Indication of a danger with low risk, in which light to medium severe physical injury or material damage can occur if it is not avoided.</p>
	<p>Attention Attention indicates a hazard that can lead to technical damage when not heeded.</p>
	<p>Environmental danger Environmental danger due to the use of substances from which a health and environmental risk proceeds.</p>
	<p>Note Indication of information that facilitates more effective and economical use of the vehicle.</p>

1.2 General safety instructions

- Apart from the instructions in this operating manual, the general safety and accident prevention regulations of the legislation must be taken into account.
- Before the vehicle is put into service, please read carefully the operating manual you receive as well as further separate instructions for additional implements or attachments and observe them in all aspects in your work.
- The vehicle may be used, maintained and repaired only by persons who have been instructed by Hako experts.
- This device may not be used by persons (including children) with reduced physical or mental abilities or by persons without sufficient experience and skills.
- You should pay special attention to the safety instructions. For errors in operating the vehicle can be avoided and trouble-free operation can be guaranteed only with precise factual knowledge.
- Please hand over these documents as well as the approval documents to the new owner/operator on sale or rental of the vehicle. Have the hand-over confirmed!
- The labels attached to the vehicle provide important information for safe operation. Renew labels that are no longer legible or present.
- The approval certificate (Part 1), valid driver's license of the vehicle driver and the operating manual must be present constantly at the place of use of the vehicle and should therefore be kept carefully in the driver's cab.
- Spare parts must be original spare parts to guarantee safety.
- The Citymaster 650 is equipped with a safety cab (ROPS – roll-over protection system) according to EU Regulation 1322/2014 Annex X.

1.3 Operating safety instructions

Before putting into service

- Risk of accident! If the steering column is unlocked while driving, it can come unexpectedly out of adjustment. You can then lose control over the vehicle.
- Risk of accident! Adjust the driver's seat only when the vehicle is stationary. You will otherwise be diverted from the traffic and could lose control over the vehicle by moving the seat. You could cause an accident by this.
- Risk of accident! A dirty, damaged seat belt or one stressed or changed in an accident may not offer the intended protection. You could therefore suffer severe injuries or death in an accident. Please check regularly that the seat belts are not damaged and not contaminated. Always have damaged seat belts or those stressed in an accident renewed by an authorised workshop.
- Risk of accident! Good viewing conditions contributing to traffic safety are guaranteed only if all windows are free of ice, snow and condensation. Make yourself familiar with the correct operation of the heating and ventilation system as well as de-moisturising/defrosting the windows. Maximum heating power and fast thawing of the windows can be achieved only if the engine has reached its operating temperature.
- There is a risk of accidents when driving with open doors! The doors must remain closed when driving on public roads and when working.
- Risk of accident! The outside mirrors image reduced in size. The visible objects are closer than they appear. Thus you can incorrectly estimate the distance from road users driving behind you, e.g. when changing lanes. Therefore check the actual distance from road users driving behind you by glancing over your shoulder.
- Check the vehicle for its correct condition and operating safety before using it. The vehicle must not be used if it is not in order.
- Before starting work, the operator must familiarize himself with all equipment, operating and actuating elements as well as with their function. It is too late to do this during operation!
- A warning triangle, a warning light, a warning vest and a first aid kit must be in the vehicle during operation.
- Sturdy and slip-proof shoes must be worn when working with the vehicle.
- This device may not be used by persons (including children) with reduced physical or mental abilities or by persons without sufficient experience and skills.
- Carrying persons is not permitted!
- Only those surfaces approved by the contractor or its authorised representative for use of the vehicle may be driven on.
- The vehicle is not suitable for removing dangerous, combustible or explosive liquids, dusts or materials.
- Observe the maximum gradability of the vehicle, see Technical data.

During operation

- Toxic engine exhaust gases! Inhaling exhaust gases is injurious to health and can lead to unconsciousness and to death! Never let the engine run in enclosed spaces.
- Danger to life in the danger area of the vehicle! Special caution is required under the raised tipper, in the area of the front and rear attachment and in the area of the trailer.
- Danger of tilting over when driving uphill or downhill and transversely to a slope! Avoid sudden turns when driving uphill or downhill or across slopes. There is a risk of tilting over in an inclined position! The vehicle speed must always be adapted to the surrounding conditions and the load condition.
- Danger of tilting due to wrong steering! Note that the steering behaviour of an articulated steered vehicle differs essentially from that of a car. Sudden steering movements at high speed or too high speeds when turning can cause the vehicle to tilt over.
- Risk of accident! Note that there is a risk of skidding on unpaved ground or snow and ice. This can lead to uncontrolled behaviour of the vehicle. Drive correspondingly carefully!
- Risk of accident! When operating at special altitudes (above 3,000 metres), the power of the engine or the engine brake decreases. Adapt your mode of operation and driving style accordingly!
- Risk of accident! Note that dirty pedals can impair the braking effect!
- For reasons of safety, the vehicle is equipped with a seat contact switch and the function of the seat contact switch must not be bypassed.
- In the case of restricted vision, especially when reversing the vehicle, it is necessary to have a second person who gives the driver appropriate signals. The second person must always be in the field of view of the driver.
- When working with the vehicle, pay special attention to third persons, especially children.
- In transport journeys on public roads the working lights must be switched off.

Shutting down the vehicle

- Risk of accident! Adopt measures against erroneous starting and unwanted movement. Engage the parking brake. Switch the engine off and pull out the ignition key.
- Risk of accident! The vehicle must be parked on firm ground. On inclinations secure the vehicle additionally against rolling away with a wheel chock.

Transporting and towing the vehicle

- Danger to life! Start driving slowly! Make sure that there are no persons in the towing area.
- Risk of injury! The vehicle may be loaded only using suitable loading aids, such as a loading ramp or drive-up planks.
- Risk of injury! After loading, make sure that the vehicle is secured according to regulations against rolling off and tilting. Use the wheels for securing the vehicle.
- Tow the vehicle using only suitable towing gear!
- The vehicle may be towed with a towing rope only if the brakes and steering are functioning!
- When the engine is still the steering has only emergency steering properties!
- The towing speed may be at most 2 km/h, the towing time at most 30 minutes and the towing distance at most 1 km!
- Secure the vehicle against unintended movement! Lock the parking brake and insert the locking strap on the articulated joint. Note that the steering is then blocked!

1.4 Safety instructions for attachments

General

- Danger to life in the danger area of the vehicle! Special caution is required in the vicinity of the articulated steering, under the raised tipper, in the vicinity of the front tool carrier, in the vicinity of the front and rear-mounted equipment and in the area between the towing vehicle and the trailer.
- Risk of injury! Put the attachment into service only if all protective devices are attached and in protection position.
- Risk of injury! Make sure that the attachments are suitable for the set oil volume. An oil volume set too high can lead to injuries due to a defect of the attachment!
- Risk of injury! High-pressure hoses, fittings and couplings are important for equipment safety. Use only high-pressure hoses, fittings and couplings recommended by the manufacturer.
- Risk of accident! When connecting attachments to the hydraulic system, ensure that the hydraulic hoses are connected correctly. Swapping the connections can lead to reverse functioning of the attachment, e.g. movement to the right rather than the left.
- Risk of accident! Front attachments not correctly fastened to the front tool carrier can drop down while driving. Always secure the front attachment with the locking devices.
- Risk of accident! You must consult Hako before attaching other attachments not approved by Hako! Check in the individual case that the relevant axial loads and total weights are complied with.
- Risk of accident! Handling, steering and braking as well as stability are influenced by attachments, trailers and the vehicle payload (e.g. full dirt hopper). For this reason, pay attention to adequate steering and braking capability as well as stability.
- Risk of accident! In Germany, if attachments extend beyond the outer lighting equipment of the vehicle or if the maximum distances of the outer lighting equipment specified according to StVZO are exceeded, the lighting equipment of the vehicle must be repeated (see Merkblatt StVZO § 30, explanations 11 and 12).

Ballast

- Risk of accident! When attaching other devices not approved by Hako, check in the individual case whether the relevant axle loads and total weights are complied with!
- Risk of accident! The front axle of the working machine must always be loaded with at least 21 % of the empty weight and the rear axle with at least 42 % of the empty weight of the working machine.
- Risk of accident! The front and rear attachments must not lead to exceeding the permissible total weight, the permissible axle load and the tyre load capacity of the working machine!
- Make sure before purchasing the attachment that these requirements are fulfilled by weighing the working machine attachment combination!

Vacuum sweeping system

- Danger to life in the danger area of the vehicle! Special caution is required under the raised tipper and in the area of the sweeping unit.
- Danger of tilting over when driving uphill or downhill and transversely to a slope! Avoid sudden turns when driving uphill or downhill or across slopes. There is a risk of tilting over in an inclined position! The vehicle speed must always be adapted to the surrounding conditions and the load condition.
- Danger of tilting due to wrong steering! Note that the steering behaviour of an articulated steered vehicle differs essentially from that of a car. Sudden steering movements at high speed or too high speeds when turning can cause the vehicle to tilt over.
- Risk of injury! Frequently check the filling level of the dirt hopper. Switch the suction fan off for this! The lid and the side doors of the dirt hopper must not be opened when the suction fan is running.
- Risk of accident! Make transport journeys only with the sweeping unit raised and secured in the transport position.
- Risk of accident! Make transport journeys only with a completely lowered dirt hopper!
- Risk of accident! The stability of the vehicle is influenced by a filled dirt hopper. Handling of the vehicle must be adapted accordingly.
- Risk of accident! Do not exceed the permissible total weight of the vehicle!
- Risk of accident! When the dirt hopper is emptied, the Citymaster 650 must be on a sufficiently load bearing, horizontal surface. Driving with the dirt hopper tilted is not permitted.
- When removing blockages in the suction hose or attaching the hand suction hose (optional), switch off the engine and wait for the suction fan to come to a standstill.
- The vacuum sweeping system may be operated only in connection with the Citymaster 650. The safety regulations for the Citymaster 650 must be complied with absolutely.

Lawn mowing system

- Danger to life in the danger area of the vehicle! Special caution is required under the raised tipper and in the area of the front mower.
- Risk of injury! Make sure that the attachments are suitable for the set oil volume. An oil volume set too high can lead to injuries due to a defect of the attachment!
- Risk of injury! Always wear protective gloves when changing blades!
- Risk of injury! Immediately renew damaged or highly unbalanced mowing blades to avoid damage to the blade bearings.
- Risk of injury! Before reinstalling, balance the blades and check them for out of true in height.
- Risk of injury! The V-belt is self-tensioning by spring force. Do not hook tension springs in or out with your bare hand.
- Risk of injury! Do not exceed the permissible total weight. There is a risk of accidents! Frequently check the filling level of the dirt hopper. Switch the suction fan off for this! The lid of the dirt hopper must not be opened when the suction fan is running.
- Risk of injury! Modifying the safety equipment is not permitted!
- Risk of accident! You must consult Hako before attaching other attachments not approved by Hako!
- The lawn mowing system may be put into operation only with the suction nozzles raised! Refer to mounting the mower on page 156!
- The lawn mowing system may be operated only in connection with the Citymaster 650. The safety regulations for the Citymaster 650 must be complied with absolutely.

Sweeping system

- Danger to life in the danger area of the vehicle! Special caution is required in the area of the articulated steering, under the raised tipper and in the area of the front sweeping roller.
- Risk of injury! When sweeping with the front sweeping machine, small stones or other parts in the snow can be thrown out by the rotating sweeping roller.
- Risk of injury! Secure the front sweeping machine against rolling away when mounting it.
- The sweeping system may be operated only in connection with the Citymaster 650. The safety regulations for the Citymaster 650 must be complied with absolutely.

Snow clearing system

- Danger to life in the danger area of the vehicle! Special caution is required in the area of the articulated steering, under the raised tipper and in the area of the front and rear attachment.
- Risk of accident due to unintended lowering of the attachment! Activate winter operation in the configuration menu only in connection with an uncoded snow blade. The front lift is then not limited downwards. Winter operation must be deactivated immediately after use.
- The snow clearing system may be operated only in connection with the Citymaster 650. The safety regulations for the Citymaster 650 must be complied with absolutely.

Transport system

- Danger to life in the danger area of the vehicle! Special caution is required in the area of the articulated steering, under the raised tipper and in the area of the trailer.
- Danger to life due to inadequately secured load! The load must be correctly distributed and fastened on the loading surface.
- Risk of injury! Modifying the safety equipment is not permitted!
- Risk of accident! Adopt measures against erroneous starting and unwanted movement. Switch the engine off and pull out the ignition key.
- Risk of accident! You must consult Hako before attaching other attachments not approved by Hako!
- The transport system may be operated only in connection with the Citymaster 650. The safety regulations for the Citymaster 650 must be complied with absolutely.

1.5 Information about special risks

Electric energy

- When working with the vehicle, maintain a safe distance from overhead electric cables. When working close to overhead electric cables, the equipment/attachments must not come into the vicinity of these cables. Danger to life! Familiarise yourself with the prescribed safety distances.
- Lightning can cause severe or fatal injury. Do not use the machine if you see lightning or hear thunder.

Exhaust gases

- Toxic engine exhaust gases! Inhaling exhaust gases is injurious to health and can lead to unconsciousness and to death! Never let the engine run in enclosed spaces.

Re-fuelling the vehicle

- Risk of fire! Diesel fuel is flammable! Take the utmost care when handling fuel. Never refuel close to naked flames or ignitable sparks. Do not smoke during fuelling. Switch off the engine, pull out the ignition key and engage the parking brake before fuelling.

Danger areas at the vehicle

- Danger to life in the danger area of the vehicle! Special caution is required under the raised tipper, in the area of the front and rear attachment and in the area of the trailer.

Danger of tilting over

- Danger of tilting over when driving uphill or downhill and transversely to a slope! Avoid sudden turns when driving uphill or downhill or across slopes. There is a risk of tilting over in an inclined position! The vehicle speed must always be adapted to the surrounding conditions and the load condition.
- Danger of tilting due to wrong steering! Note that the steering behaviour of an articulated steered vehicle differs essentially from that of a car. Sudden steering movements at high speed or too high speeds when turning can cause the vehicle to tilt over.

Unsecured load

- Danger to life due to inadequately secured load! The load must be correctly distributed and fastened on the loading surface.

Suspended loads

- Danger to life due to suspended loads! Do not stay or work under suspended loads!

Battery

- Danger of explosion due to smoking, fire or open light! Especially when being charged, but also in the normal use of batteries, batteries emit explosive gases! Avoid smoking, fire, sparks or open light in the vicinity of batteries!
- Danger of explosion due to sparks! Never place tools or other electrically conductive objects on the battery! Sparks that can ignite escaping gases arise if the poles are short-circuited. Always observe the correct order when connecting and disconnecting the battery!
 - Disconnecting the battery: First the minus pole and then the plus pole!
 - Connecting the battery: First the plus pole and then the minus pole!
- Danger of explosion due to frozen battery or too low acid level! With a frozen battery or if the acid level is too low, do not attempt to start with a jumper cable, the battery can burst or explode.
- Danger of burns due to battery acid! The special safety and accident prevention regulations must be complied with when handling the battery. Batteries contain sulphuric acid.

Noise

- Danger of injury due to noise! Sound insulation devices on the vehicle must be in their protection position during operation. If required, wear hearing protectors!

Hydraulics

- Risk of injury! Hydraulic oil issuing under high pressure can penetrate the skin and cause severe injuries. Therefore, even with the smallest wounds, consult a doctor since otherwise severe infections can arise!
- Hydraulic pipes must be run and installed correctly! The work may be done only by authorised skilled persons. Make sure that no connections are mixed up! Fittings, length and quality, especially resistance to pressure and temperature of hydraulic pipes, must comply with the requirements.

Operating and auxiliary materials

- Risk of injury! Observe the safety regulations applicable for the product when handling oils, greases and other chemical substances (e.g. battery acid or sulphuric acid)!
- There is a risk of burns and scalds! Caution when handling hot operating and auxiliary materials.

1.6 Safety instructions for maintenance and servicing

General

- Daily and weekly maintenance work can be done by the operating staff. In all other maintenance work, please contact your nearest authorised Hako dealer. Any warranty claim is null and void if this is not complied with and damage results.
- Apart from the regular general inspection (HU), the Citymaster must be maintained at regular intervals according to BGV D 29 and be checked at least annually for operationally safe condition.
- Risk of accident! Adopt measures against erroneous starting and unwanted movement. Engage the parking brake. Switch the engine off and pull out the ignition key.
- Spare parts must be original spare parts to guarantee safety.
- Use suitable tools for the cleaning and maintenance work.
- Cleaning the electrical and electronic components as well as the engine space with a high-pressure cleaner or steam cleaner is not allowed.
- Do not perform any welding, drilling, sawing or grinding work on parts of the frame. Damaged parts may be replaced only by your authorised Hako dealer.
- After cleaning, examine all fuel, engine oil and hydraulic pipes for leaks, abrasion places and damage. Immediately rectify any damage found!
- Always tighten screw connections loosened in maintenance and repair work.
- If dismantling safety devices is required in equipping, maintenance and repair work, fit and check the safety devices immediately after completion of the work.
- Perform maintenance and repair work under a jacked up vehicle or attachment only if it is safely and securely supported (hydraulic cylinders, jacks, etc. alone do not secure a jacked-up vehicle).

Engine

- Toxic engine exhaust gases! Inhaling exhaust gases is injurious to health and can lead to unconsciousness and to death! Never let the engine run in enclosed spaces.
- Danger of burns from hot parts! Do not touch any parts such as engine block, cooling system and exhaust system during operation and for some time after. Let the engine cool down.
- Risk of scalding from hot engine oil! If the cap is opened when the engine is hot, there is a risk of scalding. Let the engine cool down.
- Risk of injury due to rotating parts! Injury of limbs or hair or clothing getting caught up. Switch the engine off and pull out the ignition key.
- If the engine oil pressure warning symbol in the multifunction display lights up with the engine running, there is a risk of engine damage! Stop the vehicle in the safe range. Turn the engine off immediately and check the oil level. Have the cause of the inadequate engine oil pressure removed.
- If the diesel particulate filter in the multifunction display lights up red, the vehicle engine must be switched off immediately. Serious engine damage can be caused if this is not complied with.

Fuel system

- Risk of fire! Diesel fuel is flammable! Take the utmost care when handling fuel. Never refuel close to naked flames or ignitable sparks. Do not smoke during fuelling. Switch off the engine, pull out the ignition key and engage the parking brake before fuelling.
- Danger of burns from hot parts! Do not touch any parts such as engine block, cooling system and exhaust system during operation and for some time after. Let the engine cool down.
- There is a risk of engine damage if the fuel system is run completely empty! Inform an authorised workshop!

Cooling system

- Danger of burns from hot parts! Do not touch any parts such as engine block, cooling system and exhaust system during operation and for some time after. Let the engine cool down.
- Risk of scalding from hot coolant! The cooling system is under pressure. If the cooling system cap is opened with a hot engine there is a risk of scalding. Let the engine cool down.
- Risk of injury due to rotating parts! Injury of limbs or hair or clothing getting caught up. Switch the engine off and pull out the ignition key.
- The cooling fins are very thin and can be damaged easily!

Safety Instructions

- Small air bubbles can form when the radiator is filled. Therefore the cooling system must be vented at the same time. Have this done by an authorised workshop!

Air filter

- Danger of burns from hot parts! Do not touch any parts such as engine block, cooling system and exhaust system during operation and for some time after. Let the engine cool down.
- We can assume no liability for cleaned filter inserts. Never let the engine run without a filter insert!
- Only replace the safety cartridge, do not clean it! Never let the engine run without safety cartridge!

Hydraulic system

- Risk of injury from hydraulic oil! Hydraulic oil issuing under high pressure can penetrate the skin and cause severe injuries. Therefore, even with the smallest wounds, consult a doctor since otherwise severe infections can arise!
- Danger of burns from hot parts! Do not touch any parts such as engine block, cooling system and exhaust system during operation and for some time after. Let the engine cool down.
- Work on the hydraulic system of the vehicle may be done only by persons with special knowledge and experience in hydraulics.
- Regularly check all pipes, hoses and screw connections for leaks and external visible damage. Immediately rectify damage and leaks. Oil squirting out can cause injuries and fires. Observe the recommended replacement intervals for hydraulic pipes. Replace hydraulic hose lines every five years from the date of manufacture, even if they do not seem to be damaged!
- Do not change over hydraulic pipes! Fittings and the length and quality of the hose line must comply with the requirements.

Air conditioning system

- Risk of injury! The coolant in the air conditioning system is under high pressure. Do not open any parts of the air conditioning system. Have maintenance work on the air conditioning system done only by authorised workshops.
- Danger of burns from hot parts! Do not touch any parts such as engine block, cooling system and exhaust system during operation and for some time after. Let the engine cool down.

Wheels

- Risk of accident! Repair work on tyres and rims may be undertaken only by skilled personnel or authorised workshops.
- When changing wheels, make sure that the jack is applied to the specified jacking point.
- Damaged tyres and/or incorrect tyre pressure reduce the operating safety of the vehicle. There is a risk of an accident with tyres with too low or too high tyre pressure!
- Check the wheel nuts regularly for firm seating. After a tyre change check the wheel nuts after 50 km and tighten them if necessary.

Electrical system

- Danger of explosion due to smoking, fire or open light! Especially when being charged, but also in the normal use of batteries, batteries emit explosive gases! Avoid smoking, fire, sparks or open light in the vicinity of batteries!
- Danger of explosion due to sparks! Never place tools or other electrically conductive objects on the battery! Sparks that can ignite escaping gases arise if the poles are short-circuited. Always observe the correct order when connecting and disconnecting the battery!
 - Disconnecting the battery: First the minus pole and then the plus pole!
 - Connecting the battery: First the plus pole and then the minus pole!
- Danger of explosion due to frozen battery or too low acid level! With a frozen battery or if the acid level is too low, do not attempt to start with a jumper cable, the battery can burst or explode.
- Danger of burns due to battery acid! The special safety and accident prevention regulations must be complied with when handling the battery. Batteries contain sulphuric acid.
- Work on the electrical system may be done only in accordance with electrical engineering standards by a specialist trained for this work.
- Regularly inspect/check the electrical equipment of the vehicle. Defects such as loose connections or scorched cables must be removed immediately.
- Note the operating voltage of the vehicle!
- Use only original fuses. If stronger fuses are used, the electrical system can be destroyed and there can be fires.

- Welding work on the vehicle may be done only by authorised Hako dealers. Welding work on the vehicle leads to damage to the control electronics and can impair driving safety.

Installation of electrical devices



- The vehicle is equipped with electronic components and parts whose function can be influenced by electromagnetic emissions of other devices. Such influence can lead to danger to persons and safety-relevant functions if the following safety instructions are not complied with:
- If electrical and electronic devices and/or components, which also are connected to the vehicle electrical system, are installed subsequently in the vehicle, the user must examine in his own responsibility whether the installation causes interference to the vehicle electronics or to other components, a renewed acceptance test may be necessary.
- Above all it must be ensured that the subsequently installed electrical and electronic components comply with the EMC Directive 2004/108/EC in the relevant valid edition and bear the CE marking or an E1 approval is available.
- In addition, the following requirements especially must be fulfilled for the subsequent installation of mobile communication systems (e.g. radio, telephone):
 - Only devices with approval according to the valid national regulations (e.g. BZT approval in the Federal Republic of Germany) may be installed.
 - The device must be installed permanently.
 - Operation of portable or mobile devices inside the vehicle is permitted only through a connection to a permanently installed outside antenna.
 - The transmitter must be installed in a separate location from the vehicle electronics.
 - When installing the antenna, pay attention to correct installation with good ground connection between antenna and vehicle ground.

1.7 Environmental protection instructions

- Adequate knowledge is required for the safe handling of substances which could represent a risk to health and the environment.
- Observe the applicable laws and local regulations when disposing of detergents.
- During maintenance work and repairs, operating substances and filters have to be collected in suitable containers and properly disposed of observing the applicable laws and local regulations.
- Leaked oil, diesel fuel and lubricants etc. must not enter into the soil. Otherwise this would create a serious risk of groundwater contamination.
- Any contamination from leakages has to be cleared up without delay and disposed of properly. Used filters usually have to be disposed of as special waste (e.g. fuel filters) depending on the filtered substance.
- Ensure safe and environment-conserving disposal of operating and auxiliary materials. Take up escaping or spilled operating materials in suitable containers and dispose of them in an environmentally friendly manner.
- Used batteries with the recycling symbol contain reusable commodities. In accordance with the symbol showing the crossed-out garbage bin, these batteries must not be disposed of in the domestic waste. Return and recycling have to be arranged with the authorised Hako dealer as required in § 6 and § 8 of the German battery law (BattG)!

1.8 Shutting down and disposal

If the end of use of the vehicle or of its components is reached and this is handed over for scrapping, the components must be correctly disposed of. Here the regulations of the competent local authorities must be observed. The operating materials in the vehicle require special disposal and may not get into the environment. Further information about disposal is available through the competent local authorities and the authorised Hako dealer.

- Do not dispose of products with the symbol  at the end of their life in the domestic waste.
- Recycle used materials with the symbol  according to their labelling.
- Recycle packaging materials and do not throw them into the domestic waste.
- Recycle plastics that are identified with statement of the material, such as PPTV20 for example, and do not throw them into the domestic waste.
- Old batteries contain hazardous materials and must be returned to the distributor, disposed of correctly or delivered to a collecting point. Do not throw old batteries into the domestic waste.
- Treat operating materials such as oils, hydraulic fluids or fuels as hazardous waste and dispose of them correctly.
- Have refrigerants disposed of only by an authorised workshop with expert staff and the required technical equipment. Refrigerant may under no circumstances get into the atmosphere.
- Observe national regulations.

1.9 Labels on the vehicle

The following safety and instruction labels are affixed well legibly to the vehicle. Renew missing or illegible labels immediately.

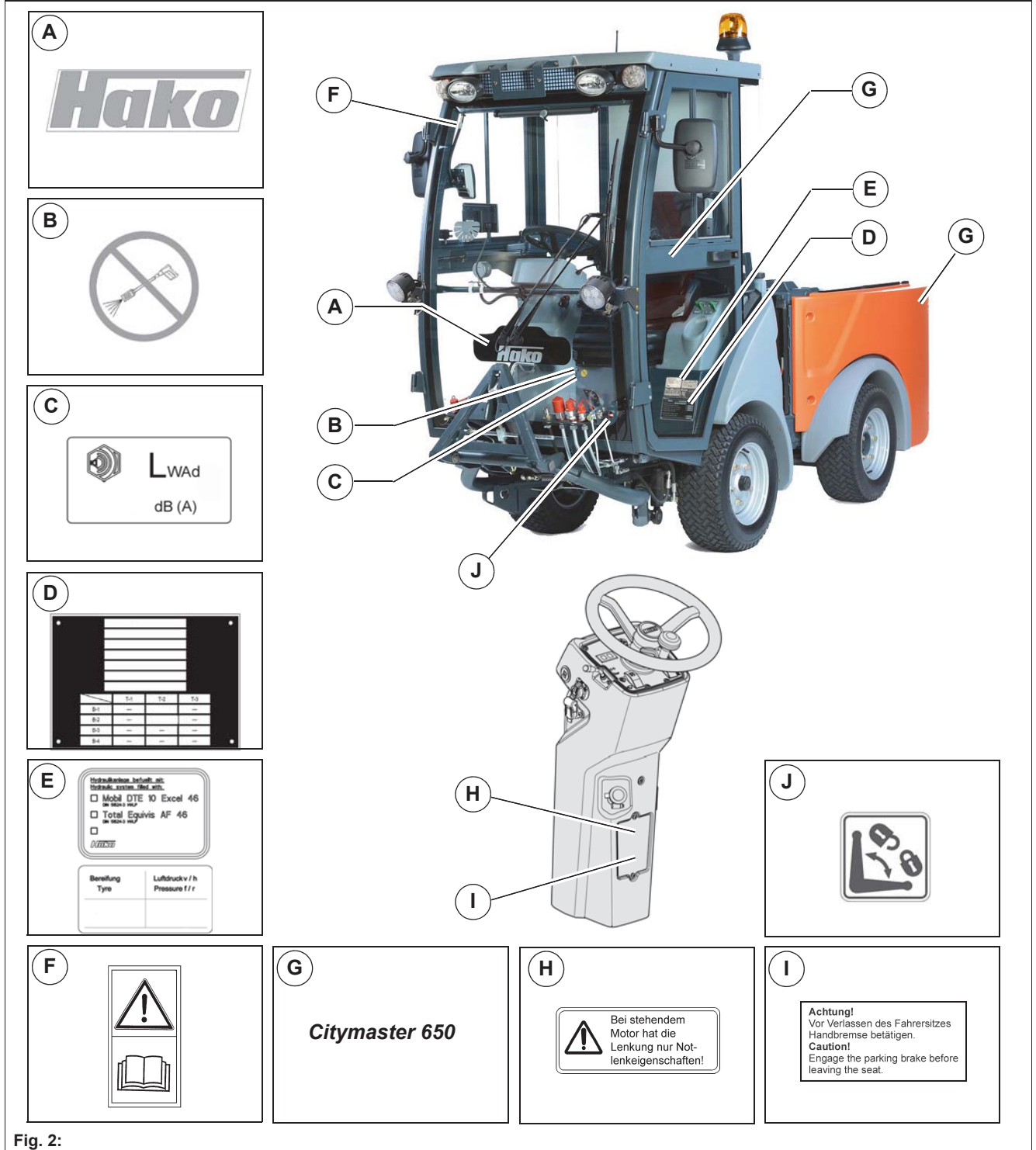

Fig. 2:

Hako company logo Fig. 2-A

The Hako company logo (147 mm x 40 mm) is located on the left and right cover of the engine.
The Hako company logo (220 mm x 60 mm) is located on the windscreen.

Label – High-pressure cleaner Fig. 2-B

The High-pressure cleaner label is located in the driver's cab under the driver's seat.

Label – Noise measurements Fig. 2-C

The Noise measurements label is located in the driver's cab under the driver's seat.

Label – Type plate Fig. 2-D

The Type plate label is located in the driver's cab under the driver's seat.
Field designations:

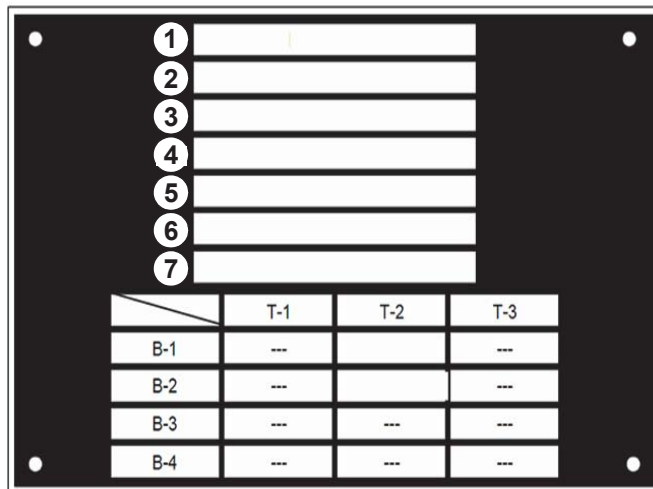

1	Name of manufacturer		
2	Class and sub-class		
3	EC type approval number		
4	Vehicle identification number		
5	Permissible gross weight		
6	Max. front axle load		
7	Max. rear axle load		
B-1	Trailer without brakes	T1	Drawbar trailer
B-2	Trailer with overrun brakes	T2	Rigid drawbar
B-3	Hydraulic brake	T3	Central axle trailer
B-4	Pneumatic brake		

Label – Tyre pressure/Hydraulic oil type Fig. 2-E

The Tyre pressure label is located in the driver's cab under the driver's seat.
The Hydraulic oil type label is located in the driver's cab under the driver's seat.

Label – Operating manual Fig. 2-F

The Operating manual label is located in the driver's cab on the front bar top right.

Label – Machine type Fig. 2-G

The Machine type label is located on both driver's doors.

Label – Emergency steering Fig. 2-H

The Emergency steering label is located in the driver's cab on the steering column.

Label – Parking brake Fig. 2-I

The Parking brake label is located in the driver's cab on the steering column.

Label – Hydraulic connection Fig. 2-J

The Hydraulic connection label is located behind the front tool carrier.

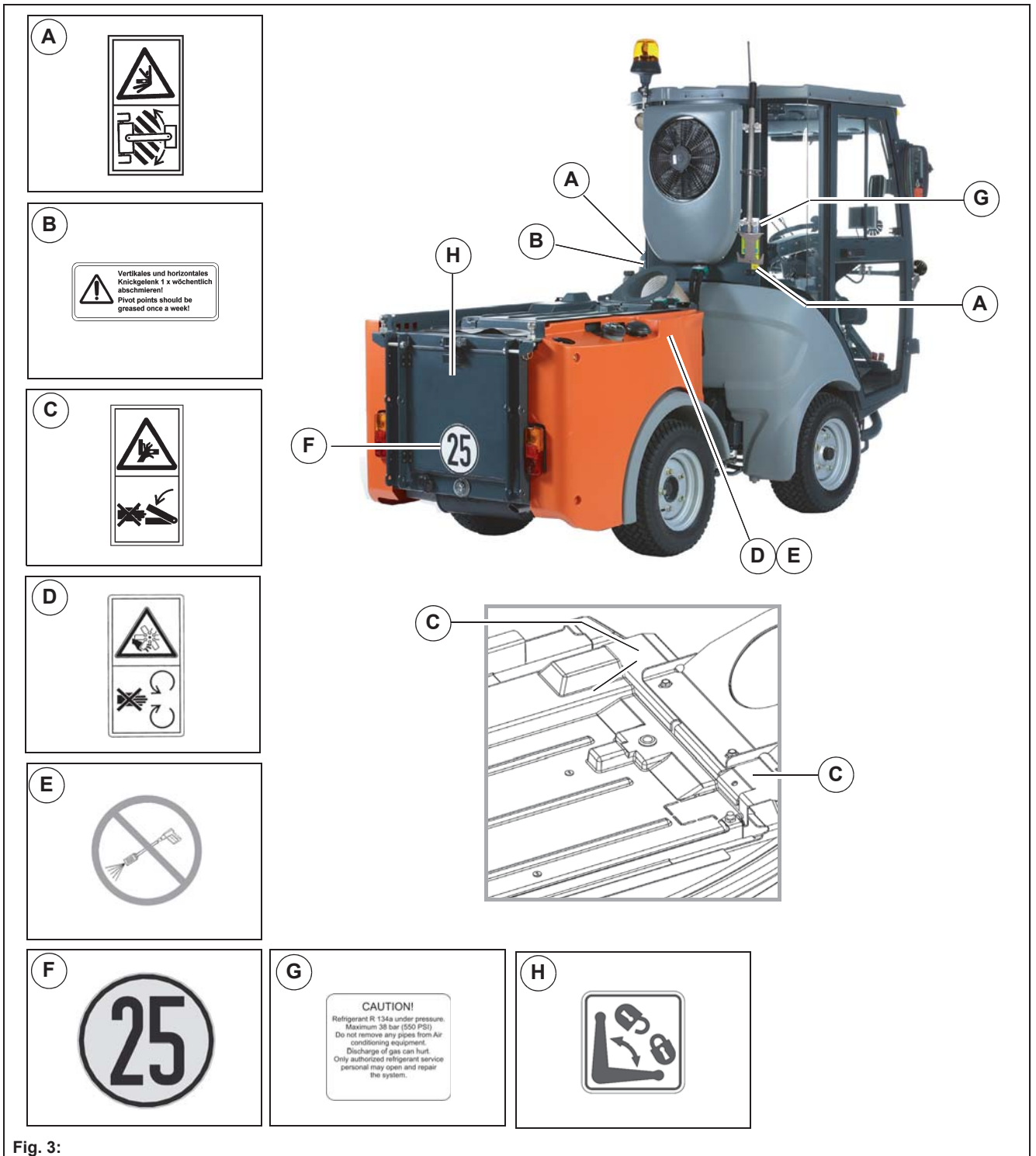

Labels – Danger in articulation area Fig. 3-A

The Danger in articulation area labels are located on the driver's cab at the rear on the left and right.

Label – Lubricate articulated joint Fig. 3-B

The Lubricate articulated joint label is located at the driver's cab at the rear on the left.

Labels – Risk of crushing Fig. 3-C

The Risk of crushing labels are located on the rear wagon on the left and right next to the suction pipe.

Label – Rotating parts Fig. 3-D

The Rotating parts label is located on the rear wagon on the left next to the suction pipe.

Label – High-pressure cleaner Fig. 3-E

The High-pressure cleaner label is located on the rear wagon on the right next to the suction pipe.

Label – Allowed maximum speed Fig. 3-F

Allowed maximum speed of the vehicle in km/h. The Allowed maximum speed label is located at the driver's cab at the rear on the right.

Label – Safety cab Fig. 3-G

The Air-conditioner label is located at the driver's cab at the rear on the right.

Label – Towing Fig. 3-H

The Towing label is located behind the door of the rear wagon.

2 Use

2.1 Overviews

The description in chapter 2 contains information on the function and handling of the individual controls on the vehicle. The controls always have the same item number in all chapters.

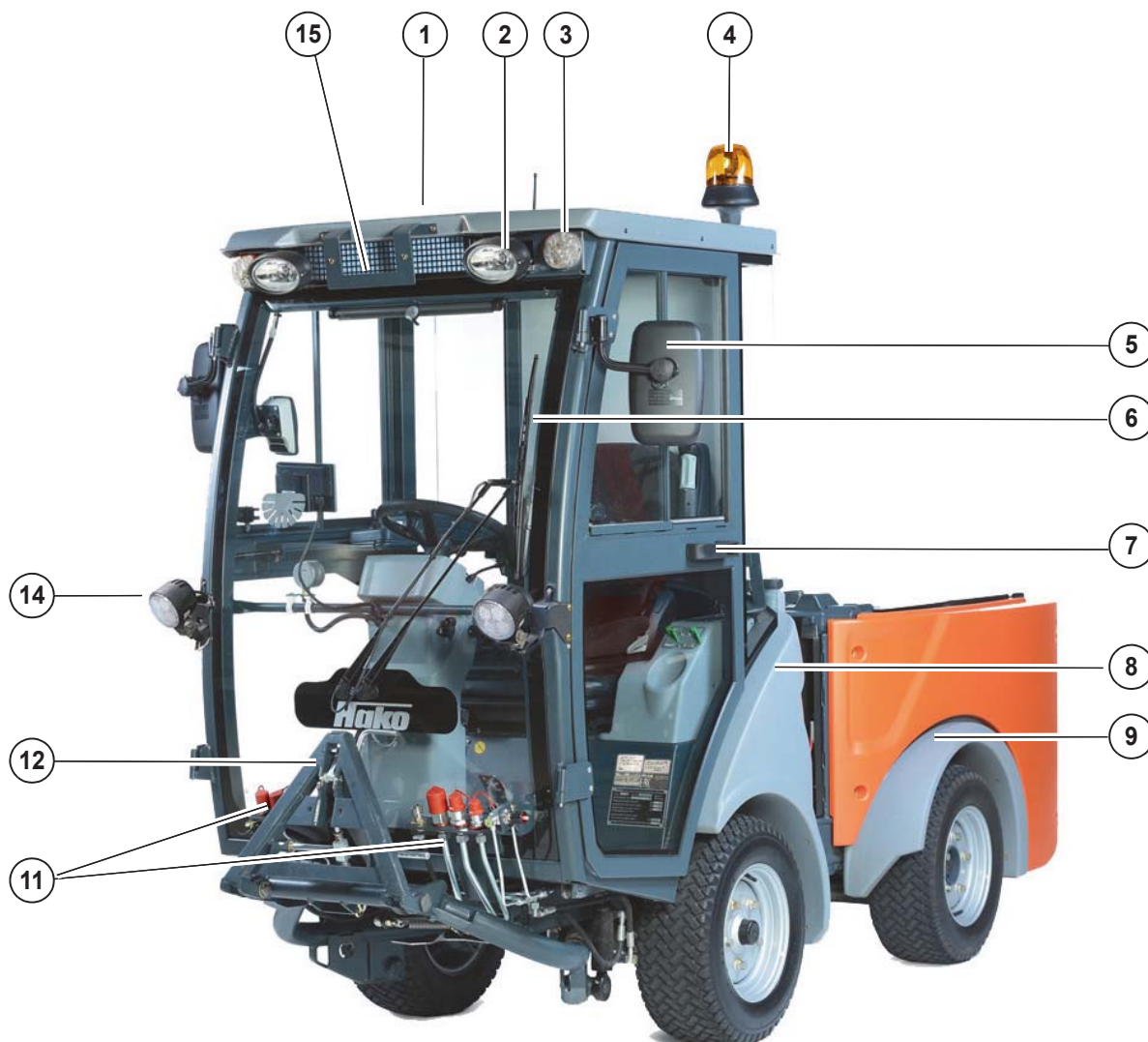

Fig. 4:

2.1.1 Front view

Item	Designation
1	Driver's cab
2	Dipped headlights
3	Direction indicator and parking light
4	Rotating beacon
5	Outside mirror (optionally heated)
6	Windscreen wiper
7	Doors
8	Fresh water tank
9	Hydraulic tank
10	Ball cock circulating water
11	Front attachment connections
12	Front tool carrier
13	Not used
14	Working light (front work area)
15	Number plate holder



Fig. 5:

2.1.2 Rear view

Item	Designation
16	7-pin socket for trailer operation
17	Direction indicator for brake lights and rear light
18	Number plate light
19	Rear attachment connections
20	Engine space
21	Circulating water coupling
22	Fuel tank
23	First aid box and warning triangle (optional)
24	Auxiliary tool
25	7-pin socket for spreader control cable (optional)
26	Rear cab working light (optional)

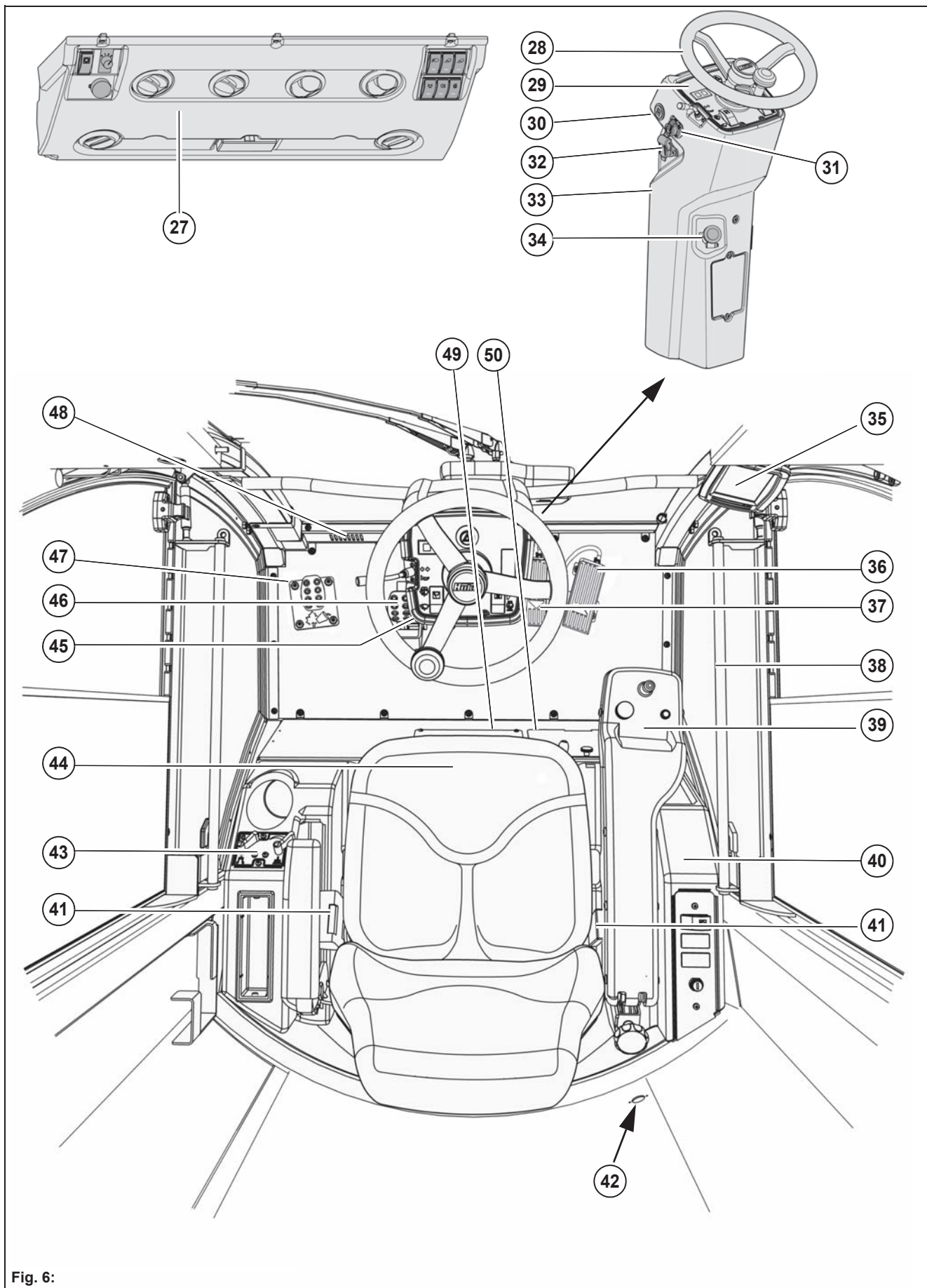

Fig. 6:

2.1.3 Driver's cab

Item	Designation
27	Inside roof control panel
28	Steering wheel
29	Steering column control panel
30	USB charging socket
31	Socket for spreader control cable on the steering column
32	3-pin socket
33	Steering column
34	Windscreen washer unit filling opening
35	Multifunction display
36	Forwards accelerator pedal
37	Reverse accelerator pedal
38	Door handle
39	Right arm rest control panel
40	Right-hand control panel
41	Seat belt
42	Socket for spreader control cable on the driver's cab outside
43	Left-hand control panel
44	Driver's seat
45	Parking brake
46	Brake pedal
47	Coarse material flap pedal
48	Foot space air vent
49	Electrical system cover
50	Water filter cover

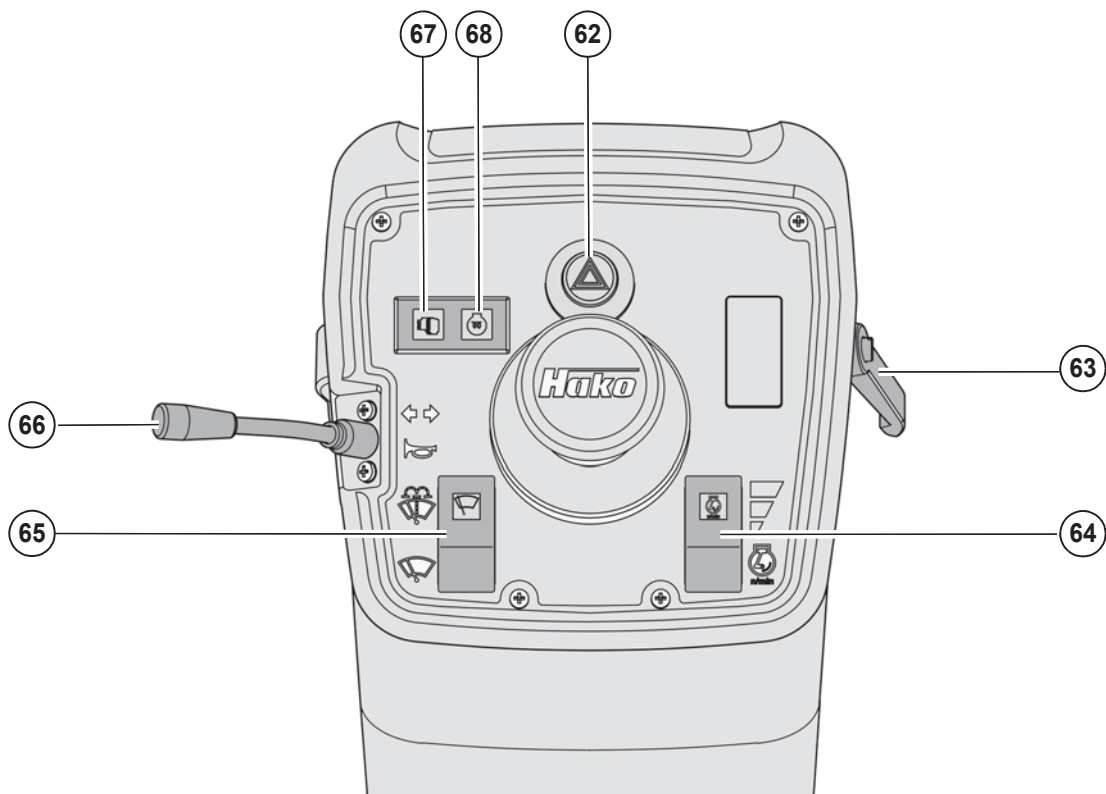
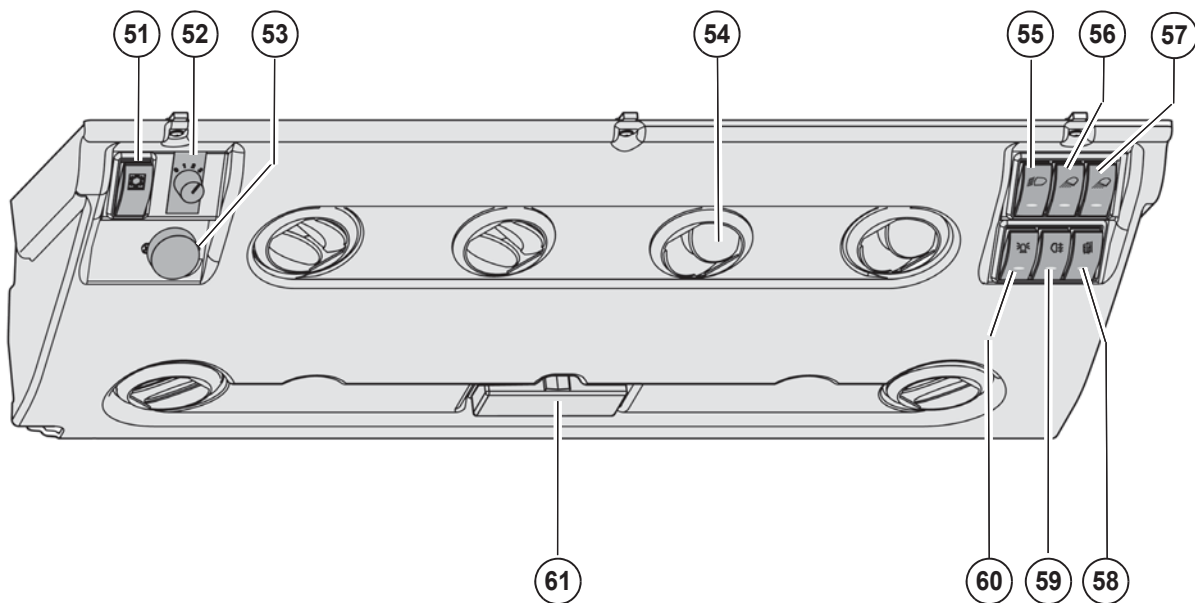

Fig. 7:

Continued – Driver's cab

Item	Designation
Inside roof control panel	
51	Air-conditioner switch
52	Suction fan controller
53	Heating controller
54	Air vent
55	Dipped headlights/side lights switch
56	Front cab working light switch (optional)
57	Rear cab working light switch (optional)
58	Mirror heating switch (optional)
59	Rear fog light switch (optional)
60	Rotating beacon switch
61	Inside light switch
Steering column control panel	
62	Hazard warning system switch
63	Steering column lever
64	Engine fixed speed switch
65	Windscreen wiper motor/water pump switch
66	Direction indicator switch/horn button
67	Engine control light
68	Preheat control light

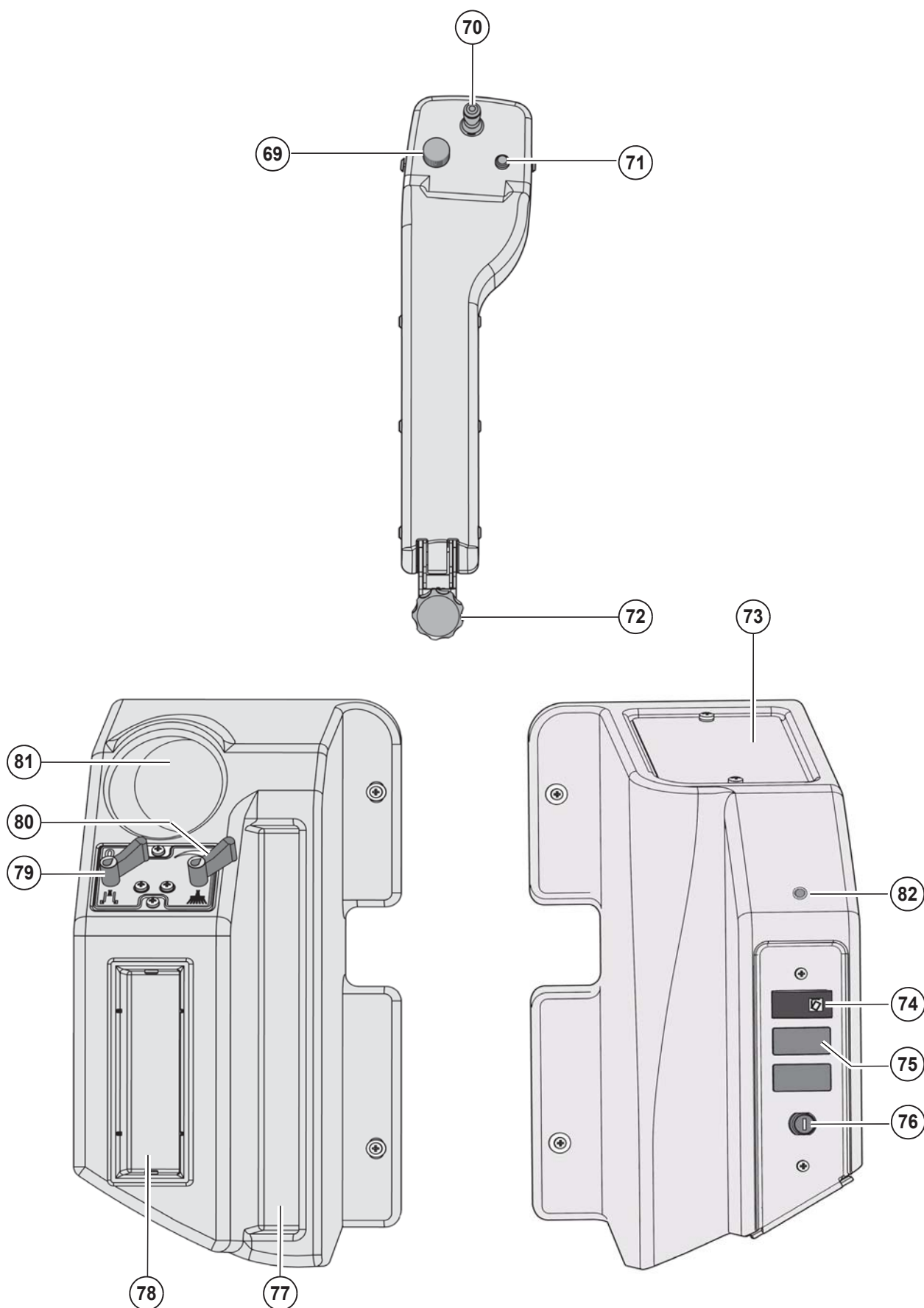

Fig. 8:

Continued – Driver's cab

Item	Designation
Arm rest control panel	
69	Turn-push knob for the multifunction display
70	Joystick
71	Hako button
72	Armrest star-shaped handle
Right-hand control panel	
73	Fuse box
74	Raise/lower dirt hopper switch
75	Charge control light
76	Ignition switch
77	Operating manual shelf
Left-hand control panel	
78	Radio installation space
79	Fresh water amount at the suction mouth lever
80	Sweeper fresh water amount lever
81	Drink holder
82	I-Button Reader

2.2 Multifunction display

2.2.1 Start screen

Functions and indicators of the vehicle are set and displayed with the multifunction display **Fig. 9-35**.

After the vehicle is switched on, the operating system and data are loaded and the start screen appears on the display. The version number of the control unit is shown on the start screen at the bottom left and the version number of the display software at the bottom right.



Fig. 9:

2.2.2 Menu guidance

The menu is operated with the turn-push knob **Fig. 10-69**. The turn-push knob is located in the right armrest of the driver's seat.

Menus and submenus are selected in the multifunction display and the individual menu item values are set or changed with the turn-push knob.

The basic principles in this case are:

- Turn to select a menu item.
- Push to activate a menu item.
- Turn to change a value.

If no setting is made for around two seconds, the cursor jumps back again.

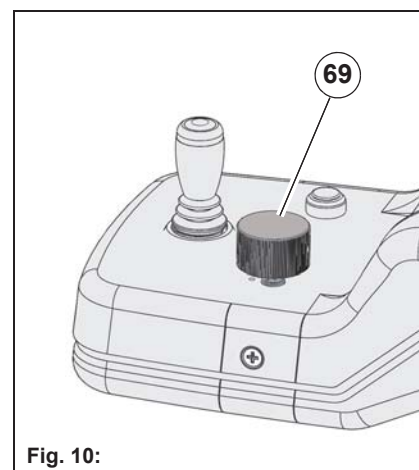

Fig. 10:

2.2.3 Menu structure

The menu structure of the multifunction display is divided into several levels.

- The information and warning symbols and the most important operating data are shown in the normal view.
- Operating settings such as the output of the hydraulic oil circuit I/II or the relief of the front tool carrier (optional) are made in the working menu (A menu).
- The pre-settings for the normal view are made in the operating menu (B menu).
- Basic settings such as date, time, units, etc. are made in the configuration menu (C menu).

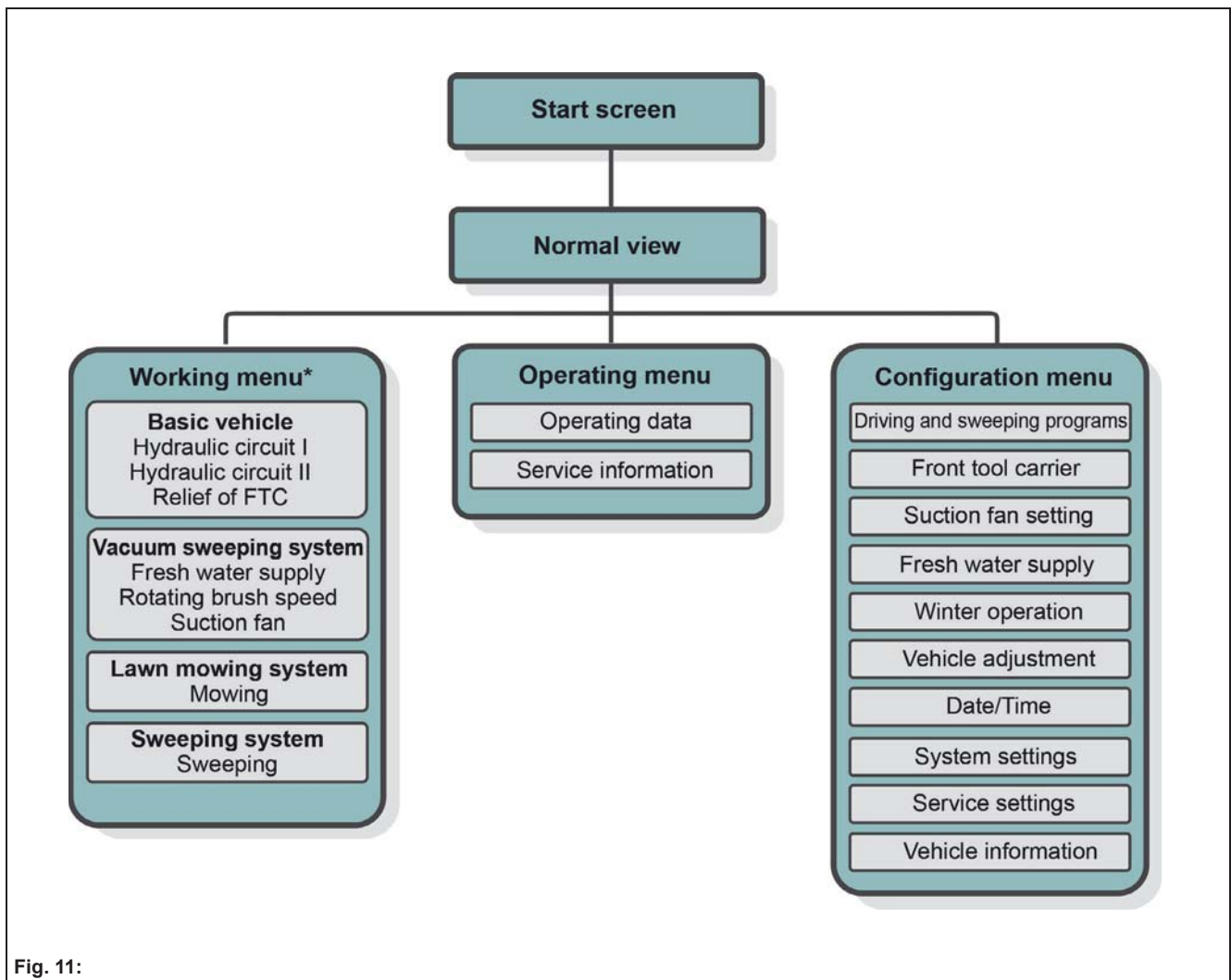

Fig. 11:

*) Optional or attachment

2.2.4 Normal view

General structure

The normal view appears automatically after the start screen. The current vehicle data are displayed in the normal view. The user can determine partially in the operating menu the vehicle data that are displayed. The other part of the vehicle data is determined by the vehicle condition (e.g. current engine speed).

The normal view **Fig. 12** is structured as follows:

- 1 Warning and information symbols
- 2 Warning and information symbols and detected attachment
- 3 Speed/pedal indicator, blinkers and time
- 4 Attachment parameters
- 5 Operating times
- 6 Service information
- 7 Current engine speed/fixed speed mode
- 8 Drive data
- 9 Hydraulic data

Vehicle data

The vehicle data are displayed as symbols, switches, bar charts or numbers.

A Symbols

- Example: Fuel supply low
Special feature:
Warning symbols are displayed red or yellow shining or flashing.
Information symbols are displayed green or white.

B On and Off switches

C Bar chart

- Example: Brush speed
The bar chart can be set from 0 to 100 %

D Numbers

- Example: Suction fan run-on (8 seconds)

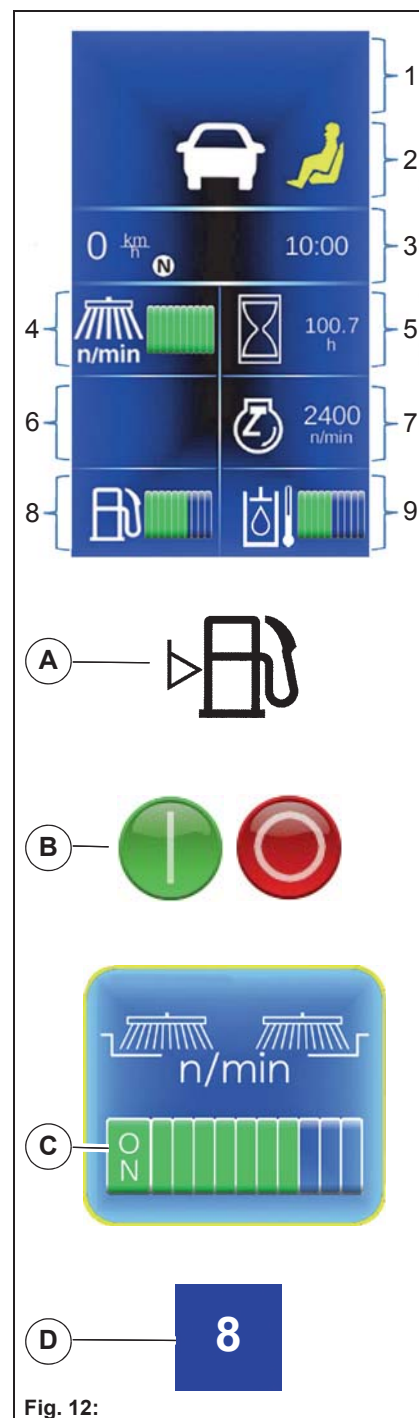

2.2.5 Working menu (A menu)



Fig. 13:

Adjustable indications are displayed on entry into the working menu **Fig. 13**. All indications are displayed one after the other by pushing the turn-push knob **Fig. 13-69**. The operator can change the values in the current display by turning the turn-push knob.

The following displays are possible according to the attachment:

- 1 Hydraulic circuit I (front attachment)
Setting range: On/Off
- 2 Hydraulic circuit II (rear attachment)
Setting range: On/Off
- 3 Fresh water supply
Setting range: On/Off
- 4 Rotating brush speed (optional)
Setting range: 0 to 100 %
- 5 Suction fan (optional)
Setting range: On/Off
- 6 Mowing system (optional)
Setting range: Mowing On/Off

Fig. 14:

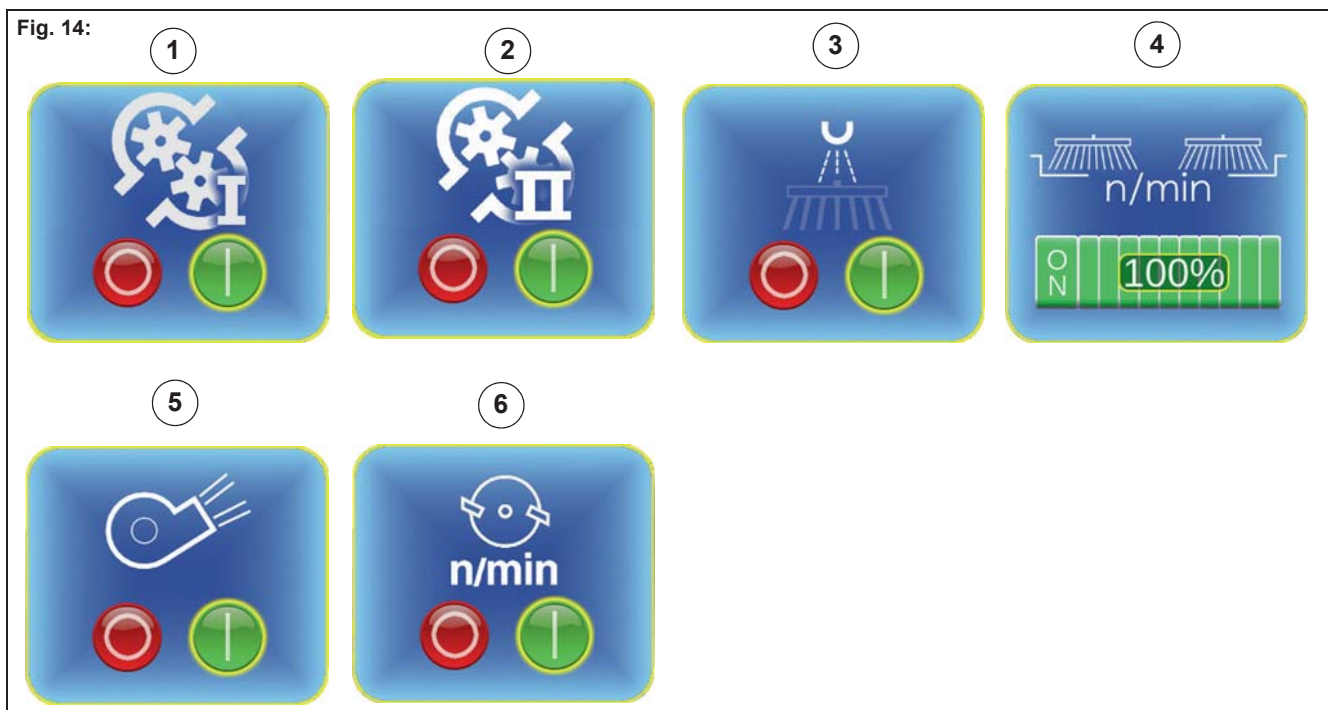

Example: Switching off the hydraulic circuit I

The following example **Fig. 15** explains how an hydraulic circuit is switched on in the working menu.

1. The normal view (**A**) is displayed.
2. Turn the turn-push knob **Fig. 15-69**: The last active function (**B**) is selected (for example, hydraulic circuit I = ON).
3. Turn the turn-push knob: The current value (**C**) is changed (for example, hydraulic circuit I = OFF)

The change is made immediately in working travel.

If the change is made in the transport driving mode, it is activated only on changing to the working driving mode.



Fig. 15:

2.2.6 Operating menu (B menu)

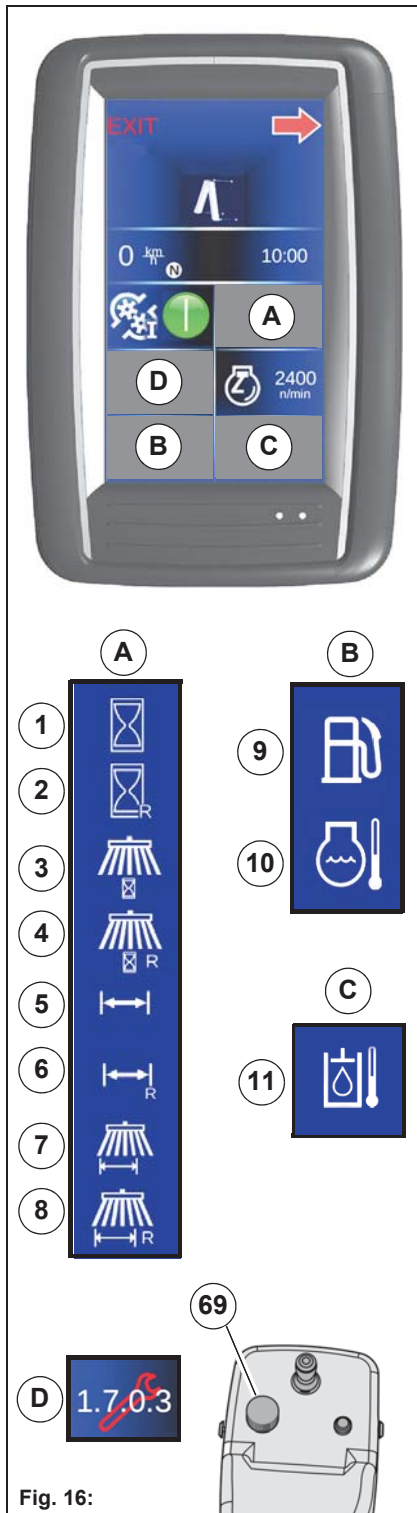

Fig. 16:

The displays of the normal view can be combined for the corresponding requirements in the operating menu **Fig. 16**. Different functions can be selected in the fields **(A)**, **(B)** and **(C)**.

The service information is displayed in the field **(D)**.

Operating data

The distances are displayed in kilometres (km) or miles (mi) depending on the system setting in the configuration menu. System setting, see page 45.

The displayed counter is reset by pushing the turn-push knob **Fig. 16-69** for a long time.

Field A:

- 1 Operating hours total
- 2 Operating hours resettable
- 3 Work hours total
- 4 Work hours resettable
- 5 Sweeping kilometres total
- 6 Sweeping kilometres resettable
- 7 Distance total
- 8 Distance resettable

Field B:

- 9 Fuel supply
- 10 Cooling water temperature

Field C:

- 11 Hydraulic oil temperature

Service information

If a service information has occurred since the ignition was switched on, a 4-digit code is displayed in **field D**. If the code is currently active, a red flashing wrench appears in addition.



Note

The displayed service information can be hidden after error rectification by pushing the turn-push knob for a long time.

Example: Selecting the fuel gauge

The following example explains how to change the operating data display from cooling water temperature to fuel gauge in the operating menu.

1. In the normal view **(A)**, push the turn-push knob **Fig. 17-69** for at least two seconds. The operating menu is activated. The cursor stands on the EXIT symbol **(B)**.
2. Turn the turn-push knob and move to the field **(C)**.
3. Push the turn-push knob. Field **(C)** is activated.
4. Turn the turn-push knob and select the fuel gauge **(D)**.
5. Push the turn-push knob. The new function is taken over.
6. Turn the turn-push knob and exit the operating menu via the EXIT symbol **(E)**.



Fig. 17:

2.2.7 Configuration menu (C menu)

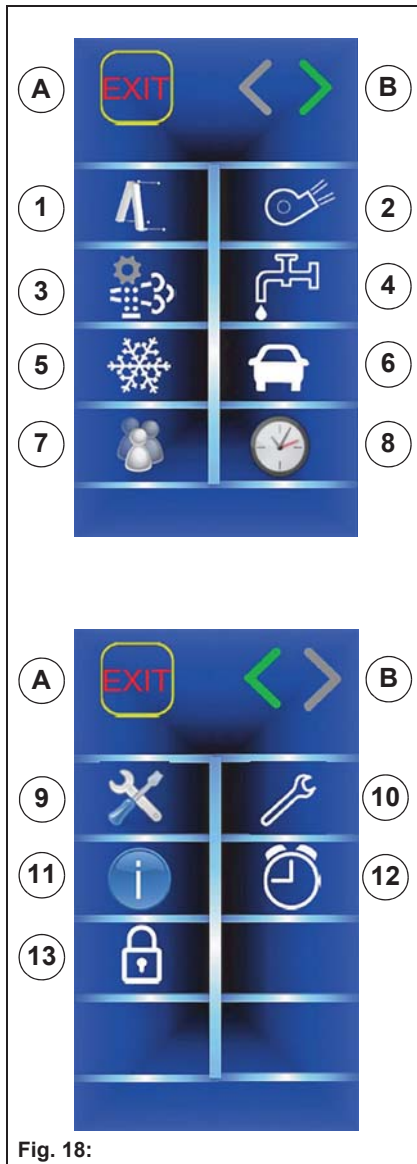

Fig. 18:

The configuration menu **Fig. 18** consists of a chapter overview which is divided into two pages. If the green arrow symbol is selected with the turn-push knob, you access the second page of the chapter overview. After selecting a symbol with the turn-push knob, it is branched into the menu where you can make settings.

- Exit the configuration menu via the EXIT symbol (A)
- Next/Previous page via the arrow symbol (B)

Requirements: The accelerator pedal must be in the neutral position.

The following menus are available:

Menu	Function
1	Front tool carrier
2	Suction fan
3	Diesel particle filter
4	Water supply
5	Winter service
6	Driving settings
7	Driving profile
8	Date/Time
9	System settings
10	Service information
11	Vehicle information
12	Service alarm clock
13	Password

Front tool carrier menu Fig. 19**A** Lower the front tool carrier with Hako button

- 0 ... Automatic OFF
- 1 ... Automatic ON

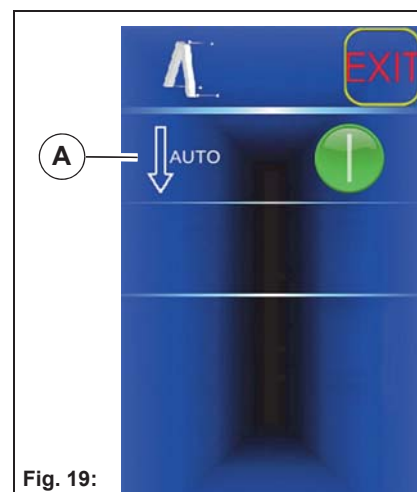

Fig. 19:

Suction fan menu Fig. 20**A** Suction fan after ignition ON

- 0 ... OFF
- 1 ... ON
- 2 ... Last value in ignition OFF

B Suction fan run-on

- 0 to 15 seconds (standard: 8 seconds)

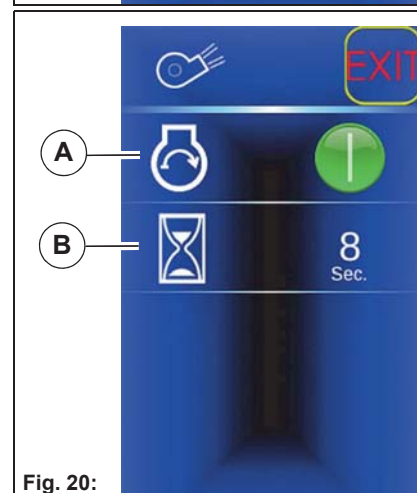

Fig. 20:

Diesel particulate filter menu Fig. 21**A** Diesel particulate filter regeneration lock

- 0 ... OFF
- 1 ... ON

B Conditions that must be fulfilled for manual regeneration**C** START symbol for starting manual regeneration**D** Status display during regeneration

Further description, see section 3.3.2.

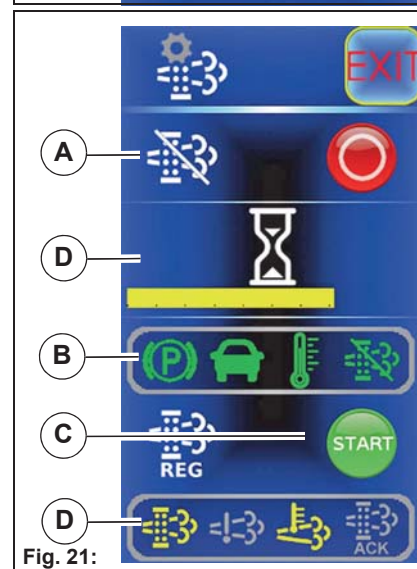

Fig. 21:

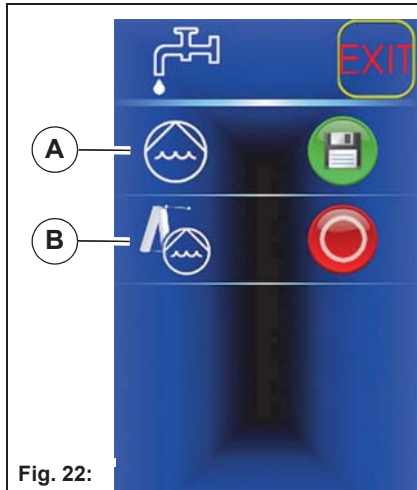

Fig. 22:

Water supply menu Fig. 22

A Water pump activation after ignition ON

- 0 ... Last value
- 1 ... Always ON

B Water pump function for uncoded attachment

- 0 ... Not available
- 1 ... Available

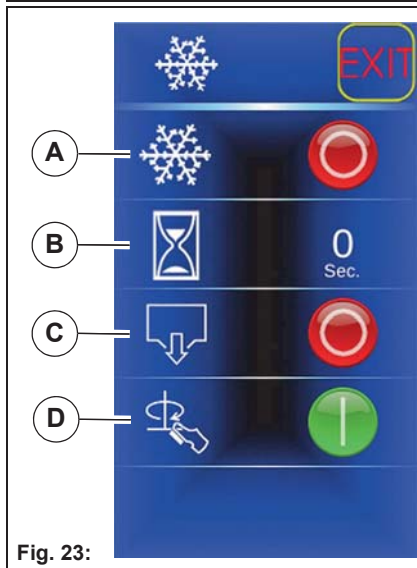

Fig. 23:

Winter service menu Fig. 23



Danger

Risk of accident due to unintended lowering of the attachment! Activate winter operation in the configuration menu only in connection with an uncoded snow blade. The front lift is then not limited downwards. Winter operation must be deactivated immediately after use.

A Winter operation ON/OFF

- 0 ... OFF (standard)
- 1 ... ON

B Spreader run-on

- 0 to 4 seconds (standard: 0 seconds)

C Spreader fast emptying ON/OFF

- 0 ... OFF
- 1 ... ON

D Spreader depending on the pedal setting

- 0 ... OFF
- 1 ... ON (standard)

Further description, see page 179

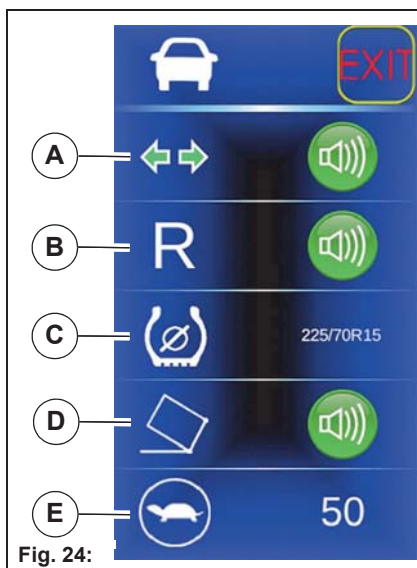

Fig. 24:

Driving settings menu Fig. 24

A Signal tone on flashing

- 0 ... OFF
- 1 ... ON (standard)

B Signal tone on reversing

- 0 ... OFF
- 1 ... ON (standard)

C Tyre type

- see selection list

D Warning tone when driving with raised dirt hopper (is automatically reset to "ON" when the dirt hopper is moved)

- 0 ... OFF
- 1 ... ON (standard)

E Speed reduction in working travel

- Adjustable: from 40 % to 100 % (standard: 50 %)

Driving profiles menu Fig. 25

- A Load settings
- B Save settings
- C Load standard values

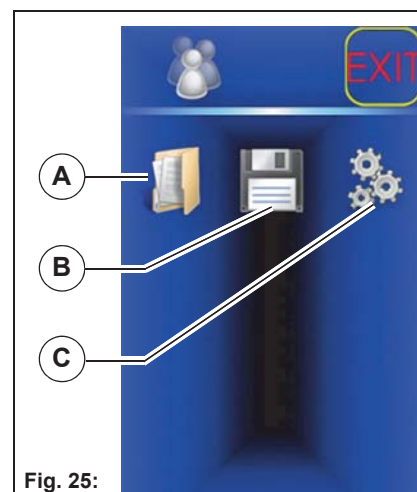

Fig. 25:

Time/date menu Fig. 26

- A Time in (hours : minutes)
- B Date in (day : month)
- C Year

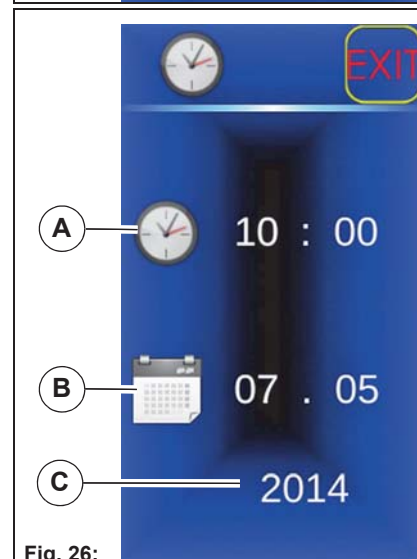

Fig. 26:

System settings menu Fig. 27

- A km/mi changeover
 - km/h (standard)
 - mi/h
- B Display brightness
 - Standard: 80 % (in automatic mode, the display brightness is controlled by a brightness sensor)
- C Overwriting the Fleet-Recorder release

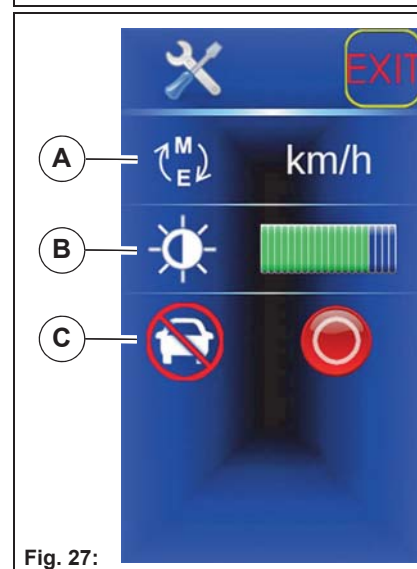

Fig. 27:

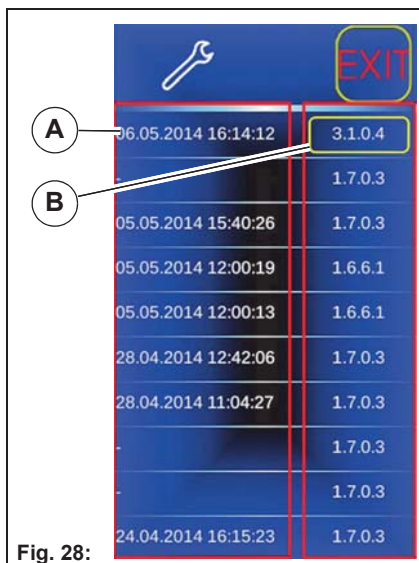

Fig. 28:

Service information menu Fig. 28

- A** If time stamp has been selected:
- The last ten items of service information are displayed with time stamp and error number
 - If no time stamp is available, the error occurred immediately at ignition ON or the display was switched off or not ready
- B** If the error code is selected and confirmed, the detailed error description sub-menu opens

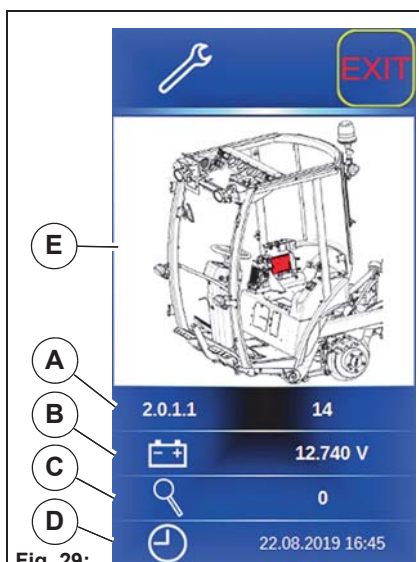

Fig. 29:

Detailed service information sub-menu Fig. 29

- A** Error code and internal error number
- B** Supply voltage at time of error in mV
- C** Additional parameter (meaning depending on error)
- D** Date when the error occurred
- E** Components involved in the error light up red in the graphic

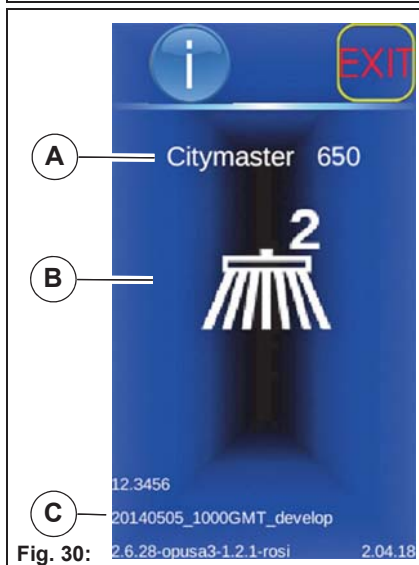

Fig. 30:

Vehicle information menu Fig. 30

- A** Vehicle type
- B** Recognised attachment
- Example: Sweeping system with two rotating brushes
- C** Software statuses

Service alarm clock menu Fig. 31

- A** Remaining time of the annual service alarm clock in days
- B** Remaining time of the operating hours alarm clock in hours
- C** Resetting the service alarm clock

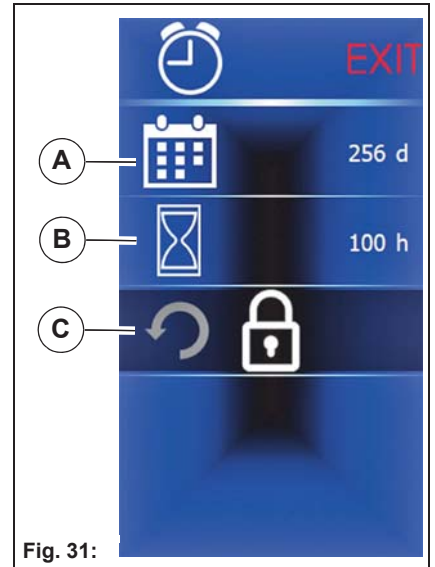

Fig. 31:

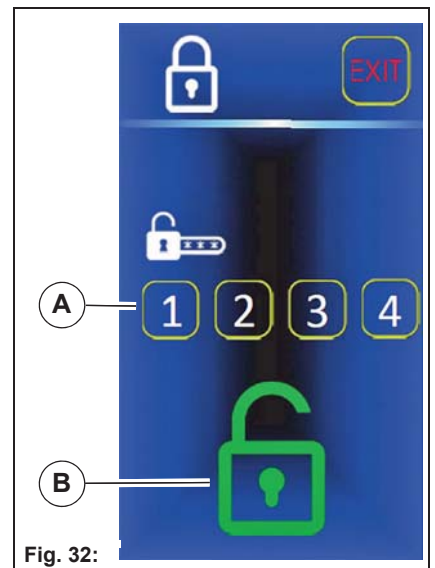

Fig. 32:

Example: Driving profile setting

The following example explains how to make a setting in the driving and sweeping program.

1. In the normal view (A), push the turn-push knob Fig. 33-69 for at least two seconds. The operating menu is activated. The cursor stands on the EXIT symbol (B).
2. In the operating menu turn the turn-push knob and move to the arrow symbol (C).
3. In the operating menu push the turn-push knob. The configuration menu is activated. The cursor stands on the EXIT symbol (D).
4. In the configuration menu turn the turn-push knob and move to the driving profile menu item (E).
5. In the configuration menu push the turn-push knob. The driving profile sub-menu is selected. The cursor stands on the EXIT symbol (F).
6. Turn the turn-push knob in the driving profile sub-menu. There are the following possibilities:
 - Loading a sweeping program with the symbol (G)
 - Resetting to defaults with the symbol (H)
 - Saving the current parameters with the symbol (I)
 - Selecting the storage place for loading or saving: 1 to 6 (J)















Use the EXIT symbol to exit the submenu.







Fig. 33:













2.2.8 Warning and information symbols

Warning symbols









Colour	Symbol	Function	Remedy
Red		Charge control	The control light of the generator lights up when the ignition is switched on, but goes out as soon as the engine is started. If the control light goes on when the engine is running, this signals: Defect on the V-belt of the generator or defect in the charge circuit of the generator. The battery is no longer being charged! Immediately stop the vehicle safely and if necessary notify an authorised workshop.
Red		Engine oil pressure low	If the warning symbol appears, there is a risk of engine damage. Immediately stop the vehicle safely and check the engine oil level.
Red		Cooling water temperature too high	If the warning symbol appears, there is a risk of engine damage. Immediately stop the vehicle safely and check the engine oil level.
Red		Hydraulic oil temperature too high	If the warning symbol appears, there is a risk of operating failure of the hydraulic system. The hydraulic oil temperature is too high! Stop the vehicle safely and switch off all hydraulic units.
Red		Parking brake on	The warning symbol appears if the parking brake is on.
Red		Hopper overload (optional)	Empty the dirt hopper immediately if the warning symbol appears.
Red		Work mode blocked	Enable work mode using the I-Button Reader (optional).
Red		Transport mode blocked	Enable work transport mode using the I-Button Reader (optional).
Yellow		Diesel particulate filter error (NCD lamp)	
Yellow		Diesel particulate filter regeneration required	
Yellow		Diesel particulate filter regeneration active	Warning of hot exhaust gases
Yellow		Diesel particulate filter locked by user	
Yellow		Engine fault	If the warning symbol appears with the engine running, there is a risk of engine damage. Immediately stop the vehicle safely and notify an authorised workshop.
Yellow		Low fuel supply	If the warning symbol flashes, then refuel without delay. There is a risk of engine damage if the fuel system is run completely empty! Inform an authorised workshop!
Yellow		Preheat	There is an engine fault if the warning symbol flashes. There is a risk of engine damage. Immediately stop the vehicle safely and notify an authorised workshop.

Yellow		Hydraulic oil level too low	Switch the engine off and check the hydraulic oil level.
Yellow		Loss of traction	Snow chains / different subsurface / different tyres
Yellow		Brake request	Operate brake
Yellow		Hopper raised	As long as the dirt hopper is not in its lower end position, the warning symbol appears.
Yellow		Driver not on driver's seat	The warning symbol appears if the driver leaves the driver's seat during operation.









Information symbols, general

Colour	Symbol	Function
Yellow		Cruise control active
Green		Vehicle blinker
Green		Trailer blinker
Green		Hazard warning system on
Green		Side and rear lights
White		Accelerator pedal in neutral position
White		Speed limiter active
White		Front switching output ON
White		Hydraulic oil temperature
White		Cooling water temperature
White		Fuel supply
White	1.1.1.1	Fault code
White		Current engine speed









Information symbols for attachments

Colour	Symbol	Function
White		Transport mode
White		Work mode with front mower
White		Work mode with 2-brush system
White		Work mode with front sweeping machine
White		Work mode with front tool carrier or unknown attachment
White		Front tool carrier floating position activated
White		Front tool carrier in upper end position
White		Winter service activated
White		Weed brush

Information symbols for attachment parameters

Colour	Symbol	Function
White		Brush speed
White		Rotation speed
White		Mower speed
White		Hydraulic circuit I
White		Hydraulic circuit II
White		Brush speed
White		Water type / fresh water
White		Rear spreader
White		Suction fan

Information symbols for operating hours and kilometre counters

Colour	Symbol	Function
White		Operating hours total
White		Operating hours resettable
White		Total sweeping hours
White		Sweeping hours, resettable
White		Total kilometres
White		Kilometres, resettable
White		Sweeping kilometres total
White		Sweeping kilometres resettable

2.3 Controls in the driver's cab

2.3.1 Steering column control panel

Adjusting the steering column



Danger

Risk of accident! If the steering column **Fig. 34-33** is unlocked while driving, it can come unexpectedly out of adjustment. You can then lose control over the vehicle.

The steering column **Fig. 34-33** can be adjusted to the corresponding driver position with a lever.

- Turn the lever **Fig. 34-A** counter-clockwise until the steering column is unlocked.
- Set the required steering column adjustment.
- Turn the lever clockwise until the steering column is locked.

Check that the steering column is locked. To do this move the steering wheel **Fig. 34-28** in the longitudinal direction.

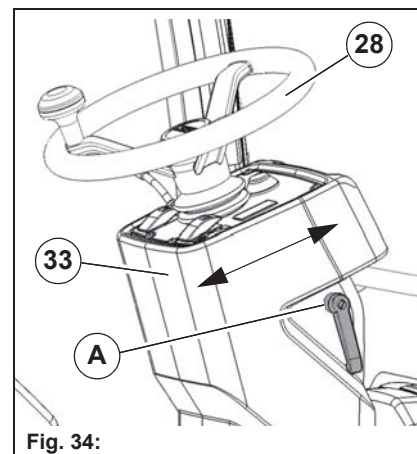

Fig. 34:

Setting the fixed engine speed

The fixed engine speed is set with the switch **Fig. 35-64**. In this case the hydraulic circuit for the front and rear attachments is changed. Set the speed according to the requirements.

Stage	rpm	Front attachment: l/min	Rear attachment: l/min
1 – ECO	1900	25	19
2 – Standard	2250	29	22
3 – Maximum	2630	35	27

The overview illustrates that sufficient power is available already in the ECO mode for many applications.

The full hydraulic output is reached as from the Standard speed.

Additional energy is available in the driving mode as well as in hydraulic circuit II at Maximum. Set the speed according to the requirements.

Operation primarily in the ECO mode lowers consumption and noise.

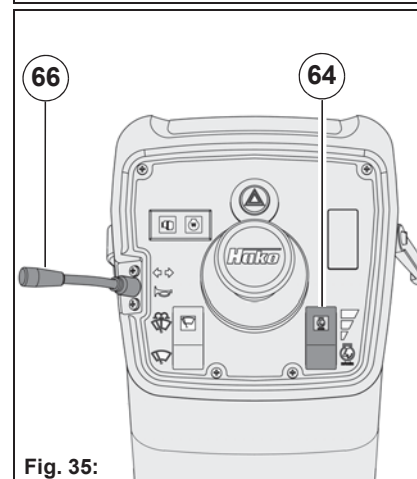

Fig. 35:

Horn

The horn is switched on and off with the button **Fig. 35-66**.

- Push the button: Horn ON
- Release the button: Horn OFF

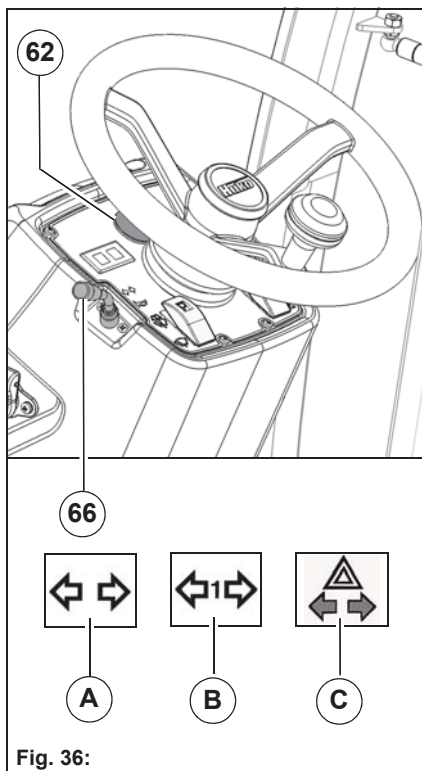

Fig. 36:

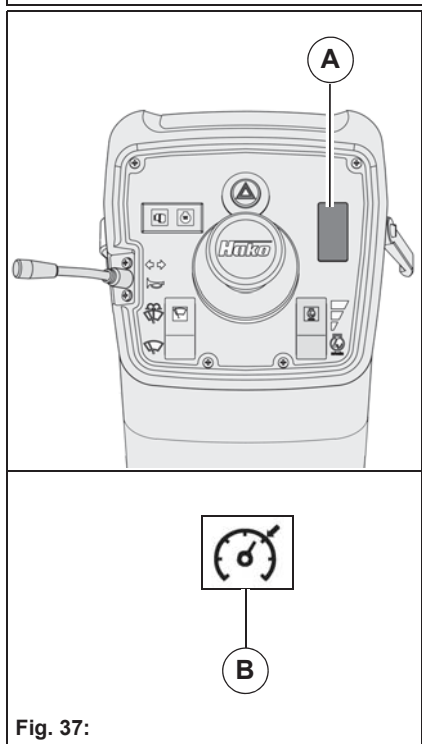

Fig. 37:

Switching the hazard warning system on and off

The hazard warning system is switched on and off with the switch **Fig. 36-62**. The direction indicators **Fig. 4-3** and **Fig. 5-17** flash. The hazard warning system also functions in position P of the ignition switch.

- Switch in stage I: Hazard warning system OFF
- Switch in stage II: Hazard warning system ON

The lamps are monitored. Fast flashing signals a defective lamp.

The warning light information symbol **Fig. 36-C** appears in the multifunction display.

Direction indicators

The direction indicators **Fig. 4-3** and **Fig. 5-17** are switched on and off with the switch **Fig. 36-66**. The direction indicators also function in position P of the ignition switch.

- Switch in stage I: Left direction indicator switch ON
- Switch in stage II: Direction indicator switch OFF
- Switch in stage III: Right direction indicator switch ON

The lamps are monitored. Fast flashing signals a defective lamp.

In the multifunction display, the flasher information symbol **Fig. 36-A** appears, or in trailer operation the trailer operation flasher information symbol **Fig. 36-B**.

Cruise control and speed limiter (optional)

Cruise control and speed limiter are available only in work mode. The current speed is set in the first position of the switch **Fig. 37-A**. In this case, the road speed is controlled so that it is not lower or higher than the speed set with the cruise control (between 1.5 and 12.5 km/h). The cruise control information symbol **Fig. 37-B** appears in the multifunction display. If the driver presses the accelerator pedal, the road speed is increased without the cruise control being deactivated. After releasing the accelerator pedal, the cruise control returns to the set speed.

Cruise control can be terminated by operating the brake, the reverse pedal, the Hako button and with the tip switch in neutral.

The speed limiter determines the maximum road speed with the accelerator pedal pushed down fully. This serves for convenient control of the road speed especially at low working speeds. The speed must be set on the configuration menu, see page 44. It is activated/deactivated via the second switch position of the switch **Fig. 37-A**.

	<p>Danger Risk of accident! Use the cruise control and the speed limiter only when the traffic situation allows!</p>
---	---

Generator control light

The control light of the generator **Fig. 38-67** lights up when the ignition is switched on, but goes out as soon as the engine is started. If the control light goes on when the engine is running, this signals: Defect on the V-belt of the generator or defect in the charge circuit of the generator. The battery is no longer being charged! Immediately stop the vehicle safely and if necessary notify an authorised workshop.

Preheat control light

The preheat control light **Fig. 38-68** lights up with the ignition switched on. The engine is preheated until the control light goes out.

If the preheat control light flashes, the preheat procedure has been interrupted and must be repeated.

If the preheat telltale flashes when the key in the ignition switch is in position 1, or during slow or fast operation, an error has occurred in the engine control unit.

USB charging socket

The USB charging socket **Fig. 39-30** is used to charge mobile devices such as tablets, smartphones, navigation devices and digital cameras via a USB cable.

Windscreen washer unit

The windscreen washer unit is used for cleaning the windscreen.

The water sprayed onto the windscreen supports the cleaning effect of the windscreen wipers **Fig. 39-6**.

The windscreen washer unit is supplied from the water tank **Fig. 39-34**. Detergents and antifreeze are added to the water as required.



Note

Do not let the windscreen wipers **Fig. 39-6** wipe over dry windscreens for a longer time. Wiper blades wear prematurely due to this and the wiper motor can overheat! Switch the windscreen wipers off with dry windscreens.

The windscreen wiper motor and the water pump are switched on and off with the switch **Fig. 39-65**.

The switch has three positions:

- Position 1: Functions of the windscreen washer unit OFF
- Position 2: Functions of the windscreen washer unit ON (continuous mode)
- Position 3 (pressed briefly): Interval operation ON/OFF
- Position 3 (pressed longer): Interval operation ON and water pump ON

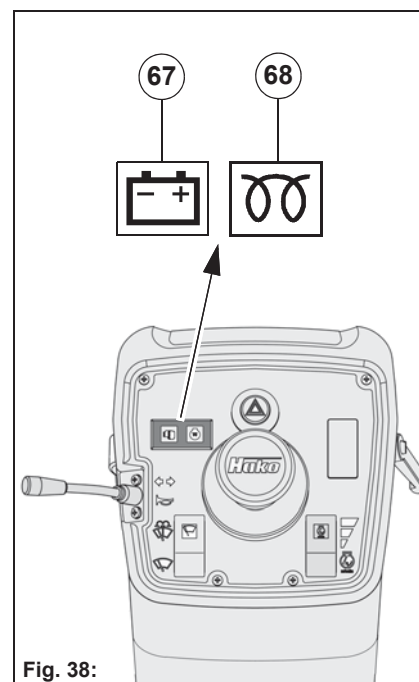

Fig. 38:

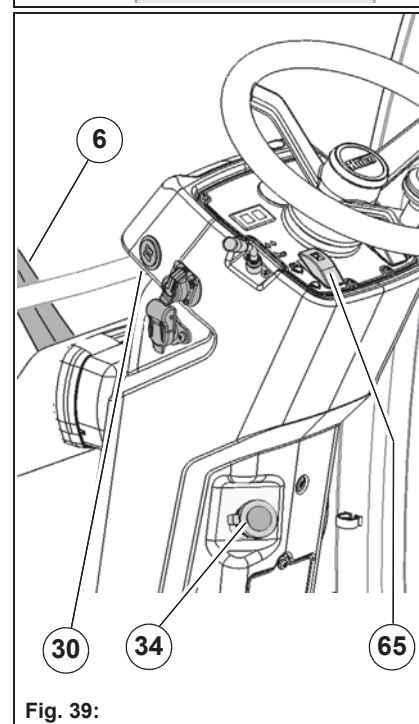

Fig. 39:

2.3.2 Comfort steering wheel (optional)

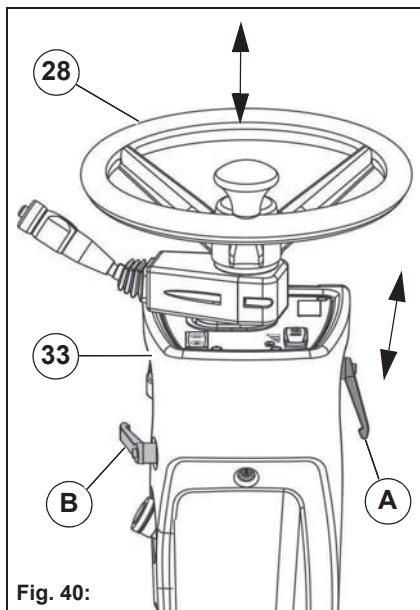

Fig. 40:

Adjusting the steering column



Danger

Risk of accident! If the steering column Fig. 40-33 is unlocked while driving, it can come unexpectedly out of adjustment. You can then lose control over the vehicle.

The steering column Fig. 40-33 can be adjusted to the corresponding driver position with a lever.

- Turn the lever Fig. 40-A counter-clockwise until the steering column is unlocked.
- Set the required steering column adjustment.
- Turn the lever clockwise until the steering column is locked.

Check that the steering column is locked. To do this move the steering wheel Fig. 40-28 in the longitudinal direction.

Adjusting the steering wheel

The steering wheel Fig. 40-28 can be moved to the relevant driver position using a lever.

- Turn the lever Fig. 40-B counter-clockwise until the steering wheel is unlocked.
- Move steering wheel to required position.
- Turn the lever clockwise until the steering wheel is locked.

Check whether the steering wheel is locked. To do this, pull steering wheel Fig. 40-28 upwards.

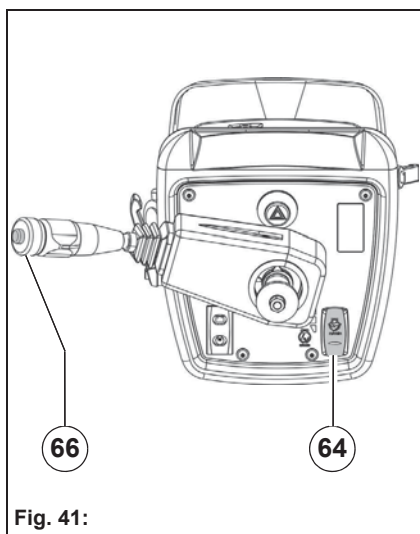

Fig. 41:

Setting the fixed engine speed

The fixed engine speed and thus the system output of the vehicle in the work mode is set with the button Fig. 41-64.

Stage	rpm	Hydraulic circuit I Litres/minute	Hydraulic circuit II Litres/minute
1 – ECO	1600	50	20
2 – Standard	2000	50/70	27
3 – Maximum	2400	50/70	32

The overview illustrates that sufficient power is available already in the ECO mode for many applications.

The full hydraulic output is reached as from the Standard speed.

Additional energy is available in the driving mode as well as in hydraulic circuit II at Maximum. Set the speed according to the requirements.

Operation primarily in the ECO mode lowers consumption and noise.

Horn

The horn is switched on and off with the button Fig. 41-66.

- Push the button: Horn ON
- Release the button: Horn OFF

Switching the hazard warning system on and off

The hazard warning system is switched on and off with the switch **Fig. 42-59**. The direction indicators flash. The hazard warning system also functions in position P of the ignition switch.

- Switch in stage I: Hazard warning system OFF
- Switch in stage II: Hazard warning system ON

The lamps are monitored. Fast flashing signals a defective lamp.

The warning light information symbol **Fig. 42-C** appears in the multifunction display.

Direction indicators

The direction indicators are switched on and off with the switch **Fig. 42-63**. The direction indicators also function in position P of the ignition switch.

- Switch in stage I: Left direction indicator switch ON
- Switch in stage II: Direction indicator switch OFF
- Switch in stage III: Right direction indicator switch ON

The lamps are monitored. Fast flashing signals a defective lamp.

In the multifunction display, the flasher information symbol **Fig. 42-A** appears, or in trailer operation the trailer operation flasher information symbol **Fig. 42-B**.

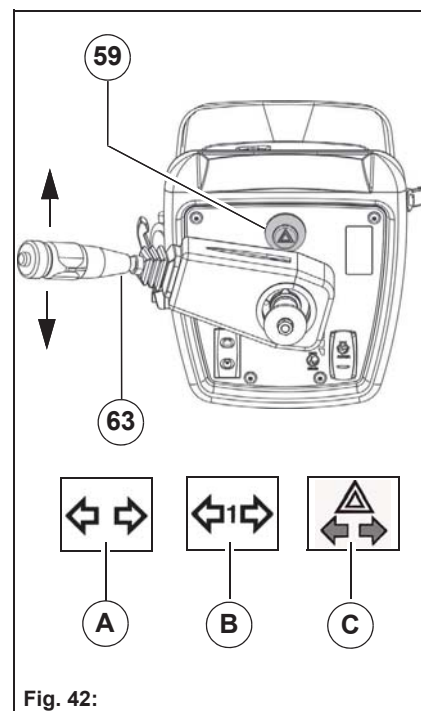

Fig. 42:

Cruise control and speed limiter (optional)

Cruise control and speed limiter are available only in work mode. The current speed is set in the first position of the switch **Fig. 43-A**. In this case, the road speed is controlled so that it is not lower or higher than the speed set with the cruise control (between 1.5 and 12.5 km/h). The cruise control information symbol **Fig. 43-B** appears in the multifunction display. The cruise control is switched off again in the neutral position of the tip switch. If the driver presses the accelerator pedal, the road speed is increased without the cruise control being deactivated. After releasing the accelerator pedal, the cruise control returns to the set speed. Cruise control can be terminated by operating the brake, the reverse pedal, the Hako button and with the tip switch in neutral.

The speed limiter determines the maximum road speed with the accelerator pedal pushed down fully. This serves for convenient control of the road speed especially at low working speeds. The speed must be set on the configuration menu, see page 44. It is activated/deactivated via the second switch position of the switch **Fig. 43-A**.

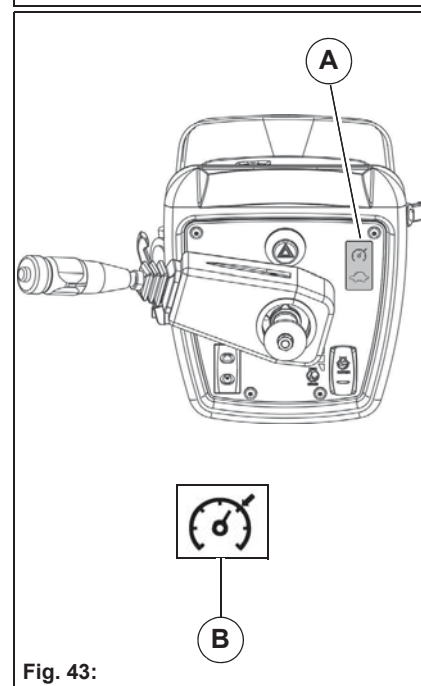

Fig. 43:



Danger

Risk of accident! Use the cruise control and the speed limiter only when the traffic situation allows!

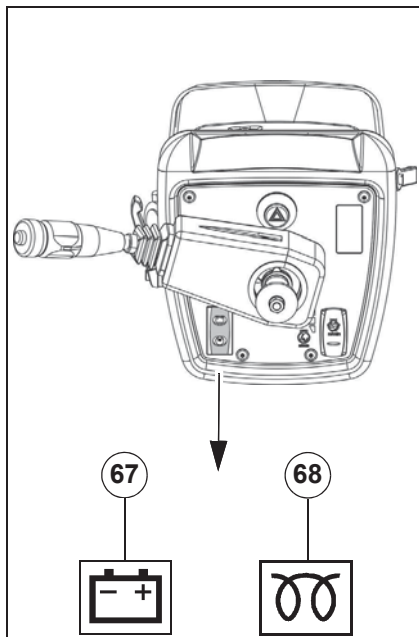

Fig. 44:

Generator control light

The control light of the generator **Fig. 44-67** lights up when the ignition is switched on, but goes out as soon as the engine is started. If the control light goes on when the engine is running, this signals: Defect on the V-belt of the generator or defect in the charge circuit of the generator. The battery is no longer being charged! Immediately stop the vehicle safely and if necessary notify an authorised workshop.

Preheat control light

The preheat control light **Fig. 44-68** lights up with the ignition switched on. The engine is preheated until the control light goes out.

If the preheat control light flashes, the preheat procedure has been interrupted and must be repeated.

If the preheat telltale flashes when the key in the ignition switch is in position 1, or during slow or fast operation, an error has occurred in the engine control unit.

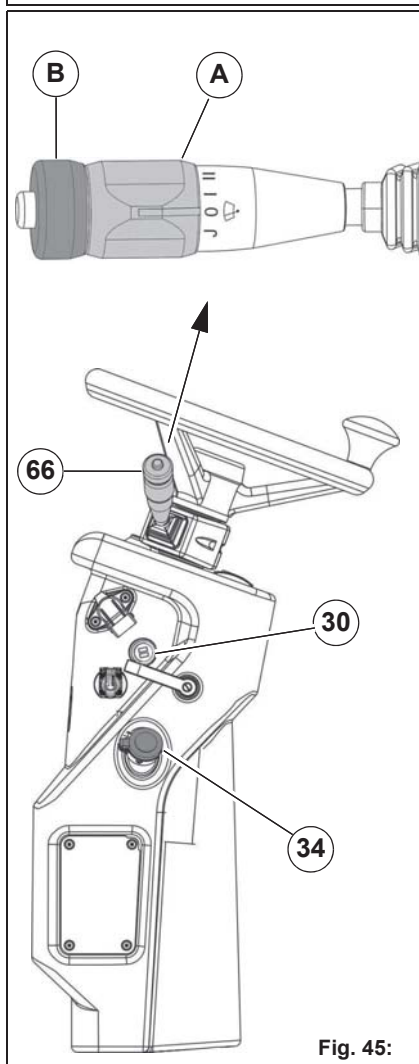

Fig. 45:

Windscreen washer unit

The windscreen washer unit is used for cleaning the windscreen. The water sprayed onto the windscreen supports the cleaning effect of the windscreen wipers.

The windscreen washer unit is supplied from the water tank **Fig. 45-34**. Detergents and antifreeze are added to the water as required.



Note

Do not let the windscreen wipers wipe over dry windscreens for a longer time. Wiper blades wear prematurely due to this and the wiper motor can overheat! Switch the windscreen wipers off with dry windscreens.

The windscreen washer unit is operated using the rotary switch **Fig. 45-A** and the button **Fig. 45-B** of the steering column switch **Fig. 45-66**.

The functions of the rotary switch **Fig. 45-A**:

- Position J: Interval ON
- Position 0: OFF
- Position I/II: Windscreen wiper ON

The functions of the button **Fig. 45-B**:

- Pressing the button switches the water pump and windscreen wiper on for a brief period.

USB charging socket

The USB charging socket **Fig. 45-30** is used to charge mobile devices such as tablets, smartphones, navigation devices and digital cameras via a USB cable.

2.3.3 Left-hand control panel

Switching on fresh water for the suction mouth

For binding dust the suction mouth is supplied with water from the circulating water system.

In addition, fresh water can be supplied to the suction mouth as required with the lever **Fig. 46-79** in the left-hand control panel.



Note

Make sure that the ball cock for the circulating water is opened, see page 72.

Setting the fresh water volume for the sweeping unit

The volume of the fresh water at the spray nozzles is set with the lever **Fig. 46-80** in the left-hand control panel. Set the volume corresponding to the requirements.

- Light contamination: Reduce fresh water volume with the lever.
- Heavy contamination: Increase fresh water volume with the lever.



Note

Switch the fresh water pump on in the C menu before adjusting the fresh water volume, see page 42.

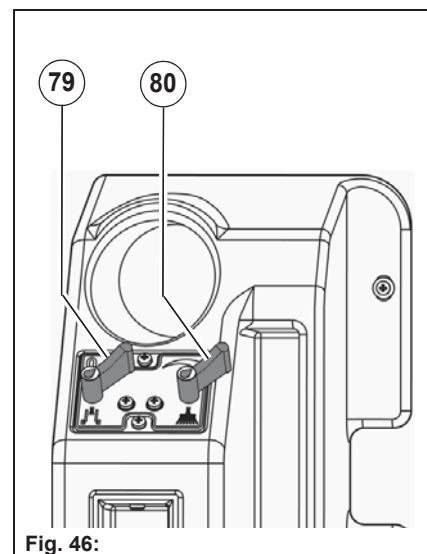

Fig. 46:

2.3.4 Right-hand control panel

Raising and lowering the tipper body

The following functions on the tipper body are switched on with the button **Fig. 47-74**:

- Button in position I: Tipper body is raised until the button is released.
- Button in position II: Tipper body is lowered until the button is released.

As long as the tipper body is not in its lower end position, the tipper body raised warning symbol **Fig. 47-A** appears.



Note

The warning sound for the raise/lower tipper body function can be switched on and off in the C menu, see page 42. Push the button again to reset the function.

Charge control light

The charge control light **Fig. 47-75** lights up when the ignition is switched on, but goes out as soon as the engine is started.

If the charge control light goes on when the engine is running, this signals:

- defective generator V-belt or
- defect in the generator charging circuit.

The battery is no longer being charged!

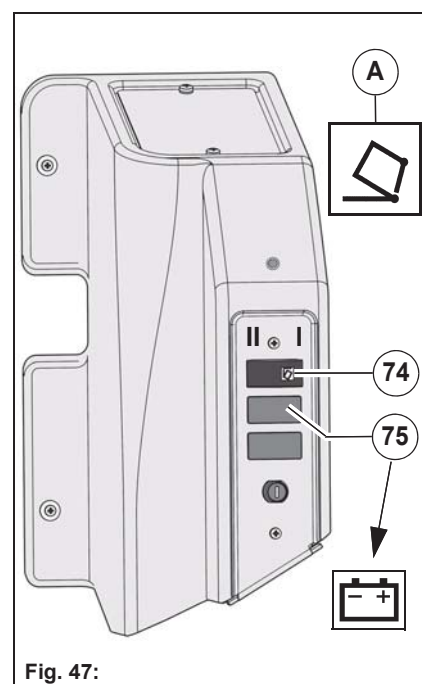

Fig. 47:

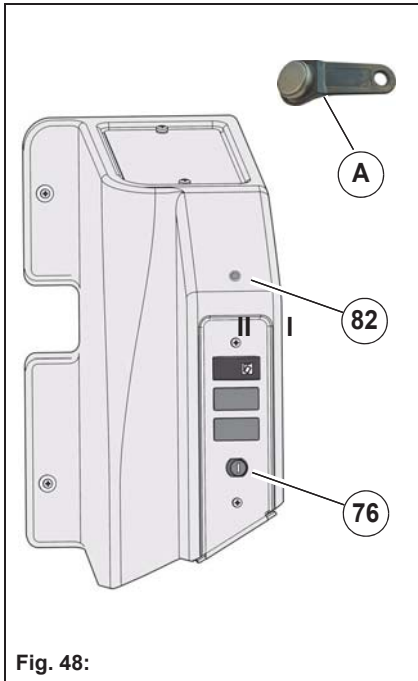

Fig. 48:

Entry.X

Access authorization is allocated using Entry.X. Entry.X can only be used with view.X.live.

Putting into service

1. Start the vehicle with the ignition switch **Fig. 48-76**.
 - Red LED of the I-Button Reader **Fig. 48-82** ON.
2. Press the I-Button Key **Fig. 48-A** against the I-Button Reader **Fig. 48-82** for one to two seconds.
 - Red LED OFF.
 - Operating data recording system active.

If the vehicle is not registered with the I-Button, the following condition arises according to the selected option:

Access authorization	Display LED	Function
No restriction (50EC001)	Red LED ON	Fully functional

	<p>Note A red illuminated LED is a request for activation of the operating data recording system via the I-Button!</p>
---	---

Ending operation

Switch off the vehicle with the ignition switch.

Ignition switch



Warning

- If the engine oil pressure warning symbol **Fig. 49-A** in the multifunction display lights up with the engine running, there is a risk of engine damage! Stop the vehicle in the safe range. Turn the engine off immediately and check the oil level. Have the cause of the inadequate engine oil pressure removed.



Note

- The engine can be started only if the accelerator pedals **Fig. 6-36** and **Fig. 6-37** are in neutral position.
- The ignition switch **Fig. 49-76** has a start repeating interlock. Switch back to position 0 for a further start.
- Do not repeat the starting procedure more than 3 times, then let the starter cool down.
- After starting the cold engine, let it warm up with slightly increased idling speed.
- In ambient temperatures of -10 °C around 20 minutes, as from +10 °C warming up is no longer required.
- The driver must be on the driver's seat for starting. Do not actuate the accelerator pedal during the starting procedure!

The ignition switch **Fig. 49-76** is used for starting the engine and for switching the electrical system on and off.

- Position P: The emergency flasher lights, side lights, rotating beacon, number plate light, rear fog light (optional) and interior light are functioning. The key can be pulled out. Position P can be reached from position 0. Push the key down and then turn it to the left.
- Position 0: The electrical system and the engine are switched off. The key can be pulled out.
- Position 1: The electrical system and the engine are switched on.
 - The parking brake warning symbol **Fig. 49-B** in the multifunction display may light up.
 - The generator control light **Fig. 49-67** lights up briefly and goes out after the engine has started and has sufficient engine speed.
 - The preheat control light **Fig. 49-68** lights up, the engine is preheated until the control light goes out.
- Position 2: Start the engine.
 - The parking brake warning light may light up.
 - Warning lights must go out.
 - If the preheat warning light flashes, the preheat procedure has been interrupted and must be repeated.
 - If the engine warning light flashes when the key in the ignition switch is in position 1, or during operation slowly or fast, then a fault in the engine control has occurred. Contact an authorised Hako workshop.
 - The ignition switch goes back into position 1.

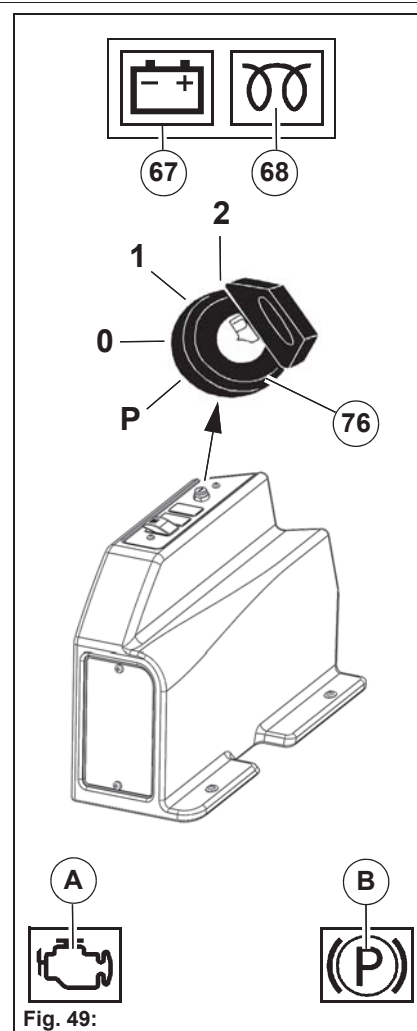

2.3.5 Arm rest control panel

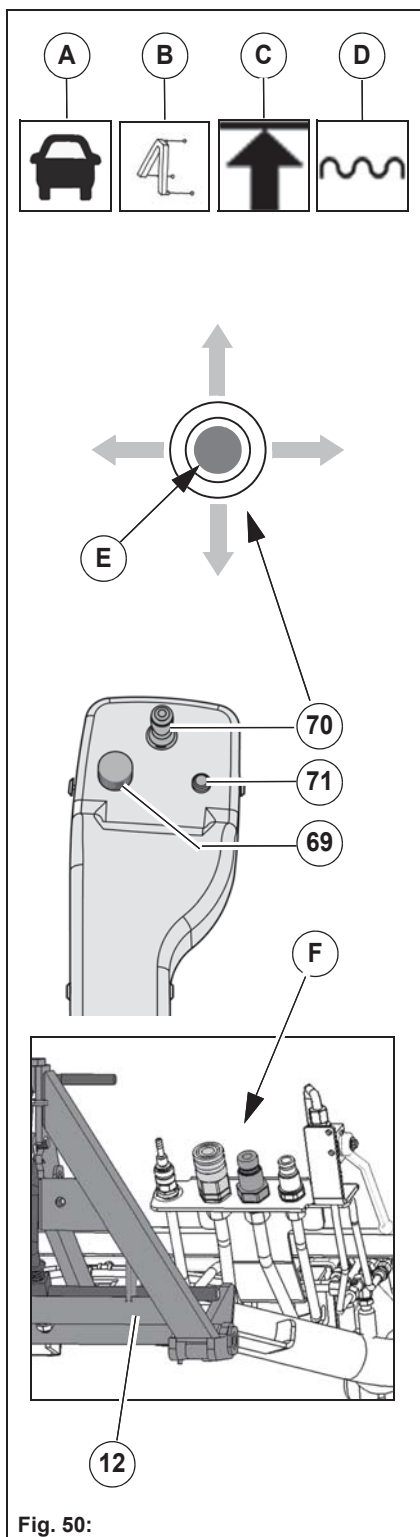

Fig. 50:

Hako button

The Hako button **Fig. 50-71** switches from transport mode to work mode or vice versa and starts automated procedures according to the attachment.

The accelerator pedals must be in the neutral position.

In the multifunction display, the transport mode **Fig. 50-A**, or front tool carrier symbol **Fig. 50-B** appears.

The vehicle speed in the:

- transport mode is 0 to 25 km/h,
- work mode 15/20/25 km/h according to selected engine speed.

You will find the functional description of the Hako button for attachments in chapter 6.

Joystick

The front tools are operated with the joystick **Fig. 50-70**. The joystick acts on the front tool carrier **Fig. 50-12** and on the hydraulic connections **Fig. 50-F**.

The following functions are possible:

- Joystick forwards: Lowering front tool carrier (floating position)
- Joystick back: Raising front tool carrier
- Joystick to the left: The front tool swivels to the left
- Joystick to the right: The front tool swivels to the right

In the multifunction display, the upper stop information symbol **Fig. 50-C** or floating position symbol **Fig. 50-D** appears.

The function of the joystick with an attachment is described in chapter 6.

Using the button **Fig. 50-E** in the joystick it is possible to control an additional hydraulic component via a changeover valve (e.g. wedge snowplough). To do so, the changeover valve of the attachment must be connected to the 19-pin X63 socket, see page 76. The additional function is active if the button is pressed and the joystick simultaneously moved.



Note

- For reasons of safety, lowering the front tool carrier with the vehicle moving is possible only in the work mode. In the transport mode, the front tool carrier can be lowered only if the accelerator pedals are in neutral position.
- If the front tool does not have to be lowered completely, interrupt the lowering movement by briefly pulling the joystick back.
- If the movement of the front tool does not agree with the movement of the joystick, change over the hydraulic connections.

Turn-push knob

The turn-push knob **Fig. 50-69** is located in the right armrest of the driver's seat. Menus and submenus are selected in the multifunction display and the individual menu item values are set or changed with the turn-push knob, see page 35.

2.3.6 Roof control panel

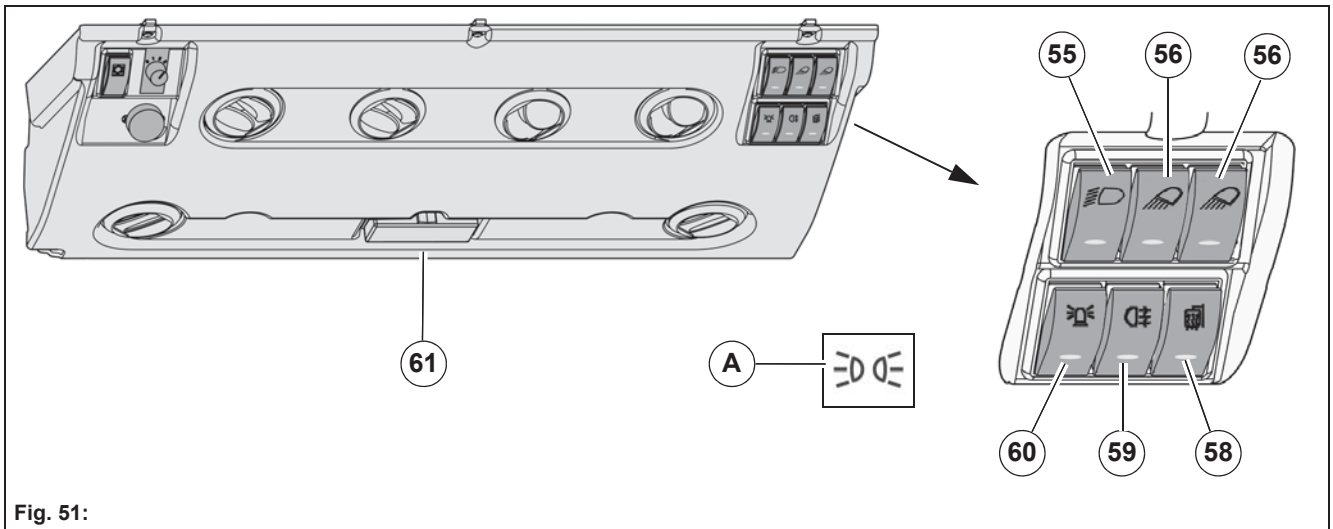

Fig. 51:

Dipped headlights and side lights

The switch **Fig. 51-55** switches the dipped headlights **Fig. 4-2**, the side lights **Fig. 4-3** and the number plate light **Fig. 5-18** on and off.

With the multifunction display switched on, the dipped headlights and side lights information symbol **Fig. 51-A** appears.

Working light

The switch **Fig. 51-56** switches the working light **Fig. 4-14** in the front work area on and off.

The switch **Fig. 51-57** switches the working light **Fig. 4-26** in the work area behind the cab (optional) on and off.

Outside mirror heating (optional)

The switch **Fig. 51-58** switches the optional outside mirror heating on and off.

Rear fog light (optional)

The switch **Fig. 51-59** switches the optional rear fog light on and off.

Rotating beacon

The rotating beacon **Fig. 4-4** is switched on and off with the switch **Fig. 51-60**.

Interior lighting

The interior lighting is switched on and off with the switch **Fig. 51-61**.

2.3.7 Accelerator pedal

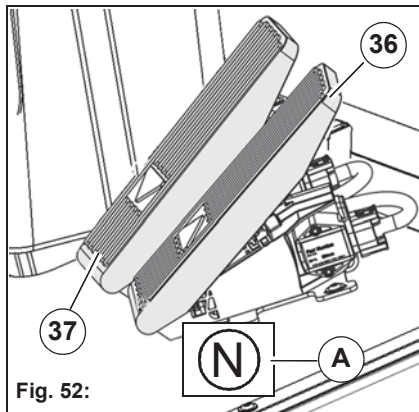

Fig. 52:

Accelerator pedal for forwards and reverse

The accelerator pedal **Fig. 52-36** is used for continuously changing the speed for driving forwards. Push the accelerator pedal down to increase the driving speed. If you release the accelerator pedal, it goes back automatically to zero position, the vehicle stops.

The accelerator pedal **Fig. 52-37** is used for continuously changing the speed for reversing. Push the accelerator pedal down to increase the driving speed. If you release the accelerator pedal, it goes back automatically to zero position, the vehicle stops.

If the accelerator pedal is in neutral position, the information symbol **Fig. 52-A** in the multifunction display lights up.

2.3.8 Coarse material flap



Note

- The coarse material flap pedal **Fig. 53-47** cannot be operated with the suction mouth raised!
- The coarse material flap must be closed again after picking up the coarse material. Fine sand is not taken up if the coarse material flap is open.

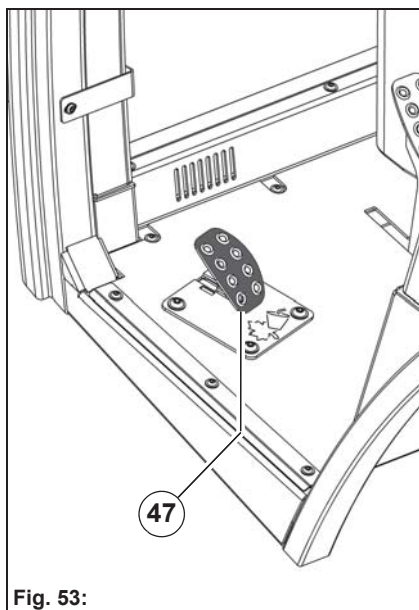

Fig. 53:

Operating the coarse material flap

If there are larger objects or coarse dirt (cans, bottles, leaves, etc.) in front of the suction mouth, you can open the coarse material flap on the suction mouth by pressing down on the pedal **Fig. 53-47**.

The pedal can be locked by shifting it to the right when it is operated. Pushing and shifting the pedal to the left with your foot will unlock it.

2.3.9 Brake system

Parking brake

The parking brake **Fig. 54-45** stops the vehicle from rolling away.

Holding the vehicle with the parking brake:

- First press the parking brake **Fig. 54-45** and then the locking lever **Fig. 54-45a**. The parking brake is locked.
- The warning symbol **Fig. 54-A** appears.
- If you drive with the parking brake on, a warning signal sounds in addition.

Releasing the parking brake:

- Press the brake pedal. The parking brake is released.
- With the parking brake released the warning light **Fig. 54-A** goes out.

Service brake

When the accelerator pedal is released (forwards or reverses) the vehicle comes to a stop quickly because of the hydrostatic braking effect. If this braking effect is not sufficient, the service brake **Fig. 54-46** can also be applied.

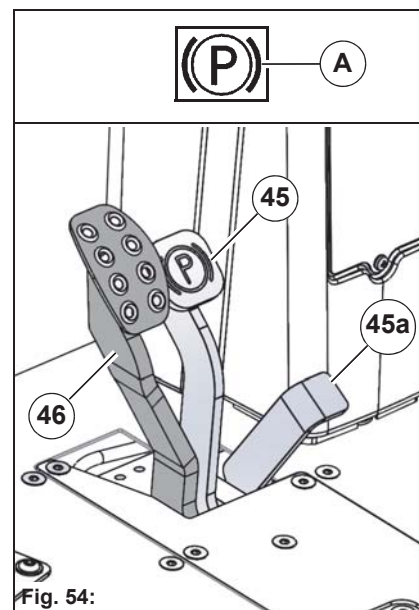

Danger

- Risk of accident! When operating at special altitudes (above 3,000 metres), the power of the engine or the engine brake decreases. Adapt your mode of operation and driving style accordingly.
- Risk of accident! Note that dirty pedals can impair the braking effect!

2.3.10 Driver's seat

The seat adjustments of the driver's seat **Fig. 6-44** depend on the equipment. The standard seat **Fig. 55-44a** has a mechanical suspension. The comfort seat **Fig. 55-44b** is air-cushioned. To reach the controls easily, the right armrest, height and longitudinal setting can be adjusted. The driver's seat is equipped with a suspension for additional comfort. If the driver leaves the driver's seat during operation, then the driver's seat warning symbol **Fig. 55-A** in the multifunction display flashes. The warning symbol goes out as soon as the driver is back on the driver's seat.

	<p>Danger</p> <ul style="list-style-type: none"> • Risk of accident! Adjust the driver's seat only when the vehicle is stationary. You will otherwise be diverted from the traffic and could lose control over the vehicle by moving the seat. You could cause an accident by this.
	<p>Warning</p> <ul style="list-style-type: none"> • For reasons of safety, the vehicle is equipped with a seat contact switch and the function of the seat contact switch must not be bypassed.

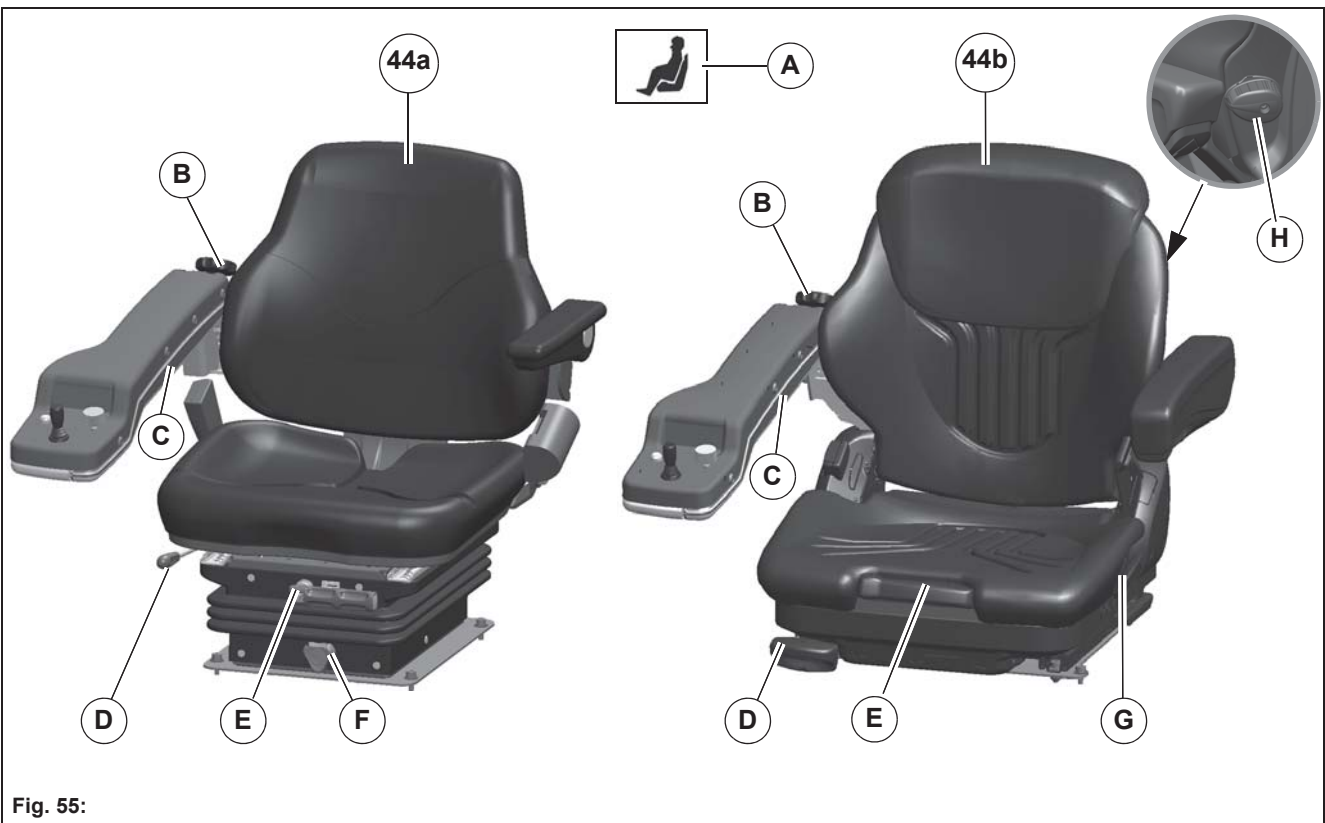

Fig. 55:

Adjusting the armrest

The armrest can be folded and its inclination can be adjusted. Turn the wheel **Fig. 55-B** to adjust the inclination. The right armrest can be unlocked with the lever **Fig. 55-C**.

Lever for longitudinal adjustment

Adjust the seat in the longitudinal direction with the lever **Fig. 55-D**.

- Pull lever up = seat unlocked. Set the seat forwards or backwards.
- Let the lever snap back after the adjustment.

Weight setting (standard seat)

For optimum suspension, the driver's seat must be adjusted to the weight of the driver with the lever **Fig. 55-E**.

- Turn lever clockwise = increase driver's weight
- Turn lever counter-clockwise = decrease driver's weight

The suspension is adjusted optimally if the indicator is in the middle.

Weight setting (comfort seat)

For optimum suspension, the driver's seat must be adjusted to the weight of the driver with the knob **Fig. 55-E**.

- Pull knob up = increase driver's weight
- Pull knob down = decrease driver's weight

The suspension is adjusted optimally if the indicator is in the middle.

Adjusting the height (standard seat)

Turn the wheel **Fig. 55-F** to adjust the height of the driver's seat.

- Turn the wheel clockwise = driver's position higher
- Turn the wheel counter-clockwise = driver's position lower

Adjusting the backrest (comfort seat)

Adjust the backrest with the lever **Fig. 55-G**. You should be on the driver's seat for the adjustment.

- Pull the lever up with you left hand.
- Move the backrest back (inclined position) by leaning your upper body back.
- Move the backrest forwards (vertically) by leaning your upper body forwards.
- Let the lever go when you have reached the optimum position of the backrest, the lever then snaps back into the desired position.

Adjusting the spine support (comfort seat)

Turn the wheel **Fig. 55-H** of the backrest to adjust the spine support.

2.3.11 Seat belt

The seat belt **Fig. 56-41** serves for the safety of the driver. The seat belt assures complete freedom of movement when pulled slowly. However, it is blocked in sudden braking. The seat belt can also be blocked when driving over potholes or other bumps in the road.



Danger

Risk of accident! A dirty, damaged seat belt or one stressed or changed in an accident may not offer the intended protection. You could therefore suffer severe injuries or death in an accident. Please check regularly that the seat belts are not damaged and not contaminated. Always have damaged seat belts or those stressed in an accident renewed by an authorised workshop.

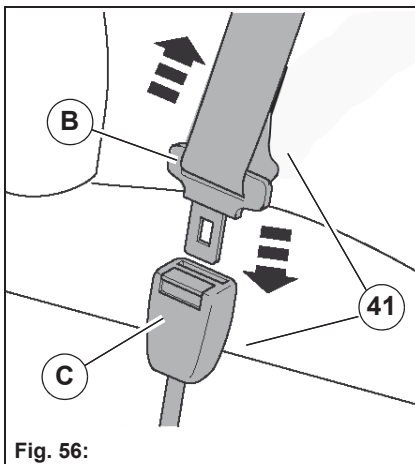

Putting seat belts on and off

Insert the buckle latch **Fig. 56-B** into the belt buckle **Fig. 56-C** until it snaps in audibly (check by pulling). Tension the seat belt by pulling on the end. The seat belt must always lie firmly against your pelvis.

Make sure you are sitting upright and the belt runs correctly!

To take off the seat belt hold it firmly and press the red button on the belt buckle **Fig. 56-C**. Guide the seat belt slowly up to the reel.

2.3.12 Cab heating



Danger

Risk of accident! Good viewing conditions contributing to traffic safety are guaranteed only if all windows are free of ice, snow and condensation. Make yourself familiar with the correct operation of the heating and ventilation system as well as de-moisturising/defrosting the windows. Maximum heating power and fast thawing of the windows can be achieved only if the engine has reached its operating temperature.

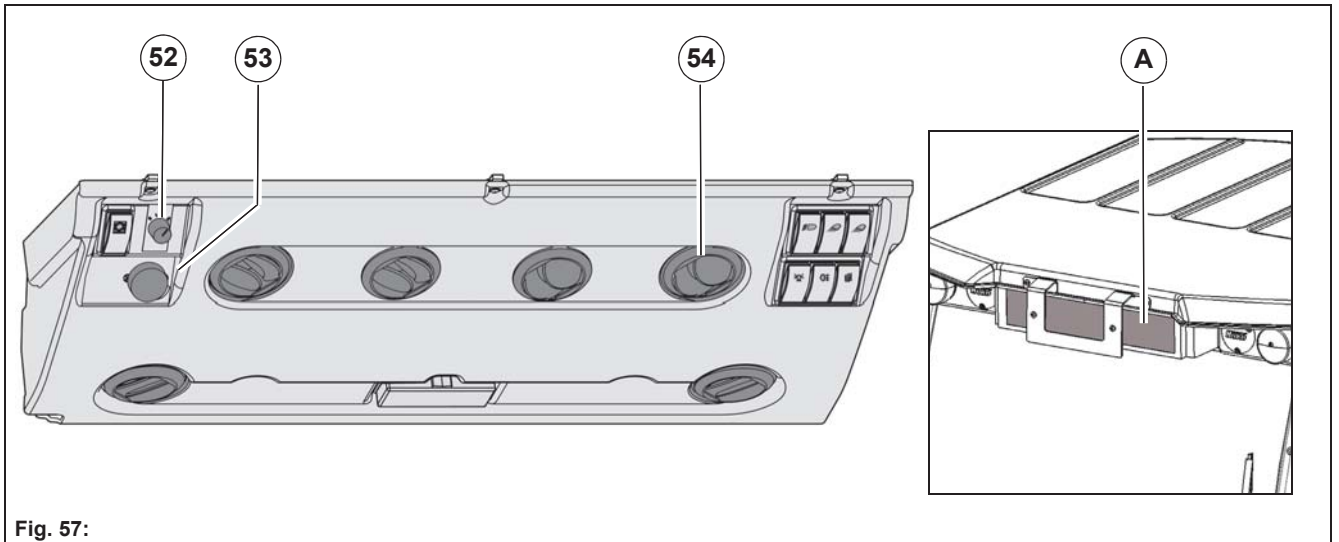

Fig. 57:

The vehicle is equipped with cab heating. Two operating conditions can be selected with the cab heating:

- Ventilation
- Heating

The air flow is transported by a 3-stage suction fan to the air vents

Fig. 57-54 of the windscreen and through the air vents **Fig. 6-48** of the foot well into the driver's cab.

Adjusting the ventilation

The ventilation is set with the controller **Fig. 57-52**.

- Controller in position 0: Suction fan OFF
- Controller in position 1: Suction fan runs in stage 1
- Controller in position 2: Suction fan runs in stage 2
- Controller in position 3: Suction fan runs in stage 3

Setting the temperature

The temperature is set with the controller **Fig. 57-52**.

- Setting warmer: Turn the controller clockwise
- Setting colder: Turn the controller counter-clockwise

Cab air filter

The installed cab air filter **Fig. 57-A**, which is located beneath the number plate holder **Fig. 4-15**, filters out largely dust and pollen. A clogged filter reduces the air supply into the vehicle interior. Therefore please observe the filter changing intervals, see page 101.

2.3.13 Air conditioning system



Danger

Risk of injury! The coolant in the air conditioning system is under high pressure. Do not open any parts of the air conditioning system. Have maintenance work on the air conditioning system done only by authorised workshops.

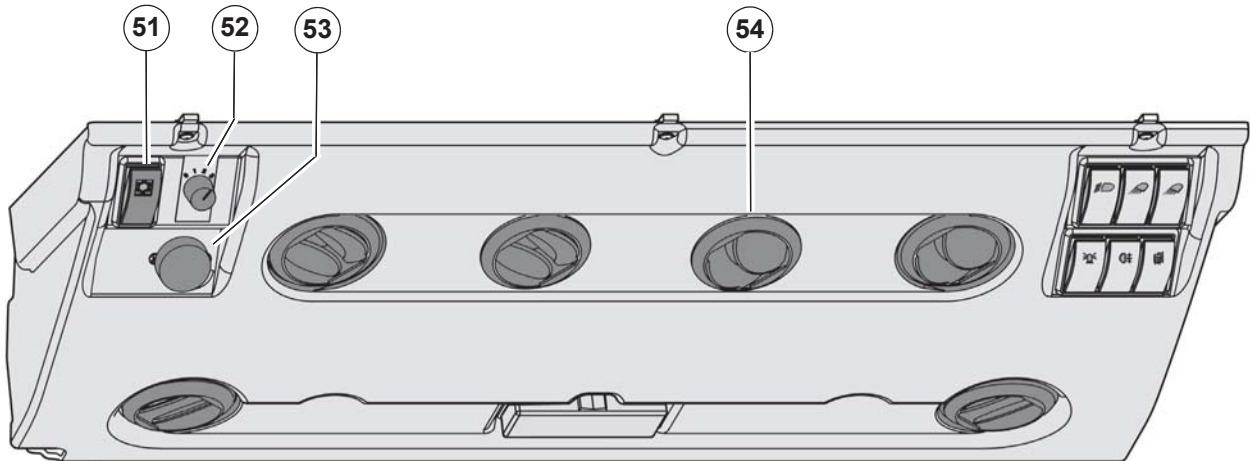

Fig. 58:

The air conditioning system regulates the temperature and humidity of the vehicle interior and filters unwanted substances out from the air.

The air conditioning system is operational only when the engine is running. It functions optimally only if the side windows are closed.

The air flow is transported by a 3-stage suction fan to the air vents

Fig. 58-54 of the windscreen and through the air vents **Fig. 6-48** of the foot well into the driver's cab.

In warm weather ventilate the vehicle for a short time only. In this way you accelerate the cooling process and the desired vehicle interior temperature is reached faster.

Observe the recommended setting, otherwise the windows can mist over. Switch the air conditioning off only briefly and the circulating air on only briefly.

Switching the air conditioning on

- Switch the air conditioning on with the switch **Fig. 58-51**. The control light on the switch goes on.
- Set the air supply on the controller **Fig. 58-52**.
- Set the temperature with the controller **Fig. 58-53** to 18 °C to 22 °C.

2.3.14 Doors



Danger

- There is a risk of accidents when driving with open doors! The doors **Fig. 59-7** must remain closed when driving on public roads and when working.
- Risk of accident! The outside mirrors **Fig. 59-5** image reduced in size. The visible objects are closer than they appear. Thus you can incorrectly estimate the distance from road users driving behind you, e.g. when changing lanes. Therefore check the actual distance from road users driving behind you by glancing over your shoulder.

Opening doors from the outside

To open the doors **Fig. 59-7** insert the key in the door lock **Fig. 59-A**, turn it counter-clockwise and push it.

Opening doors from the inside

To open the doors pull the lever **Fig. 59-B** upwards.

Adjusting the side windows

The left and right side windows are opened or closed with the catches **Fig. 59-C**. Push the catch up and move the window correspondingly.

Outside mirrors

You have an extended field of view due to the convex outside mirrors **Fig. 59-5**.

Adjusting the outside mirrors

Adjust the outside mirrors so that the roadway and the rear work area are completely visible.

The outside mirrors can be folded down.

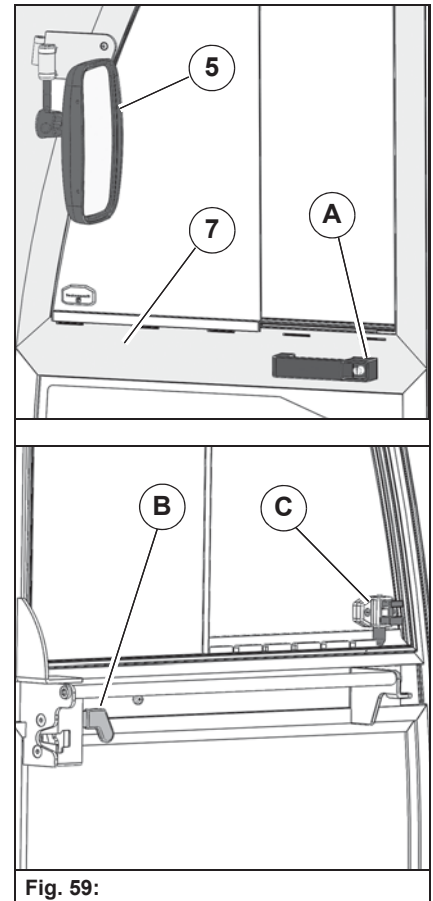
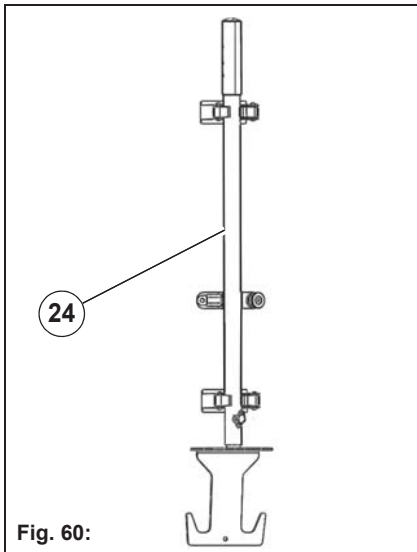

Fig. 59:

2.4 Operating elements on the vehicle

2.4.1 Auxiliary tool



The auxiliary tool **Fig. 60-24** is located on the driver's cab at the rear on the right. This auxiliary tool has the following functions:

- For mounting the suction mouth, see page 127.
- For removing coarse dirt from the suction mouth and suction duct, see page 144.
- For cleaning the dirt hopper, e.g. if leaves clog up the sieves, see page 145.
- As lever for the hand pump of the rear structure (optional). For raising the dirt hopper/loading platform in the case of an engine failure.

2.4.2 Ball cock circulating water

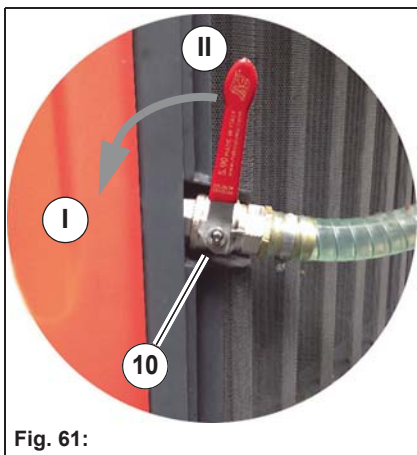

The circulating water is closed off only with the ball cock **Fig. 61-10** for maintenance purposes. In normal operation the ball cock must be opened!

- Circulating water supply opened: Ball cock in position **Fig. 61-I**
- Circulating water supply closed: Ball cock in position **Fig. 61-II**



Note

Close off the circulating water supply only if there is circulating water in the dirt hopper and the suction mouth should be mounted or dismounted, see page 127.

2.4.3 Front tool carrier

The front tool carrier **Fig. 62-12** is used for holding an attachment.



Danger

Risk of accident! Front attachments not correctly fastened to the front tool carrier can drop down while driving. Always secure the front attachment with the locking devices **Fig. 62-A** and **Fig. 62-B**. Always secure non-Hako tools with the locking device **Fig. 62-C**.

Taking up the front tool carrier

1. Drive the vehicle up to the attachment and lower the front tool carrier with the joystick **Fig. 8-70**.
2. Bring the locking hook **Fig. 63-A** into the rear position and the lever **Fig. 63-B** into the upper position (II). Pick up the chain **Fig. 63-C** and hook in onto the hook **Fig. 63-E**.

Drive under the take-up of the attachment and carefully raise the attachment with the front tool carrier. Raising the front tool carrier is interrupted if the driver leaves the driver's seat.

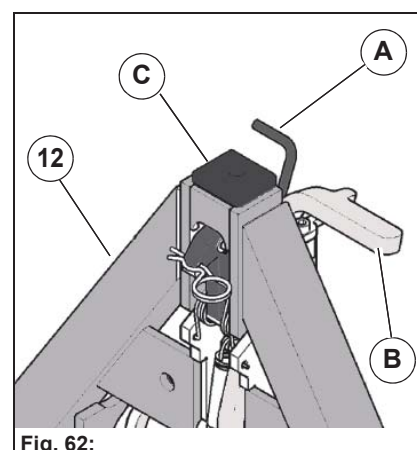

Fig. 62:

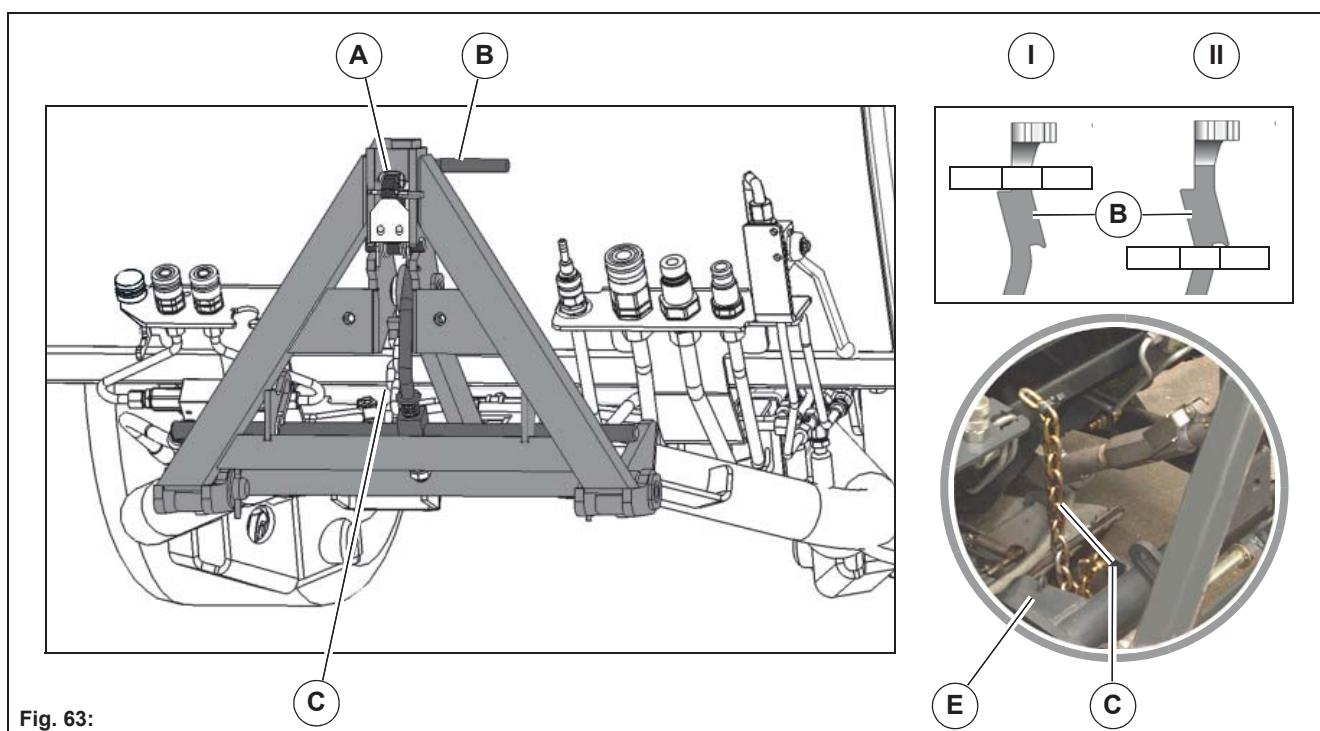

Fig. 63:

Securing the front tools

1. Bring the locking hook into the front position and the lever into the lower position (I).
 2. The movement limiter of the front tool carrier is determined by the chain **Fig. 65-C** and the hooking point of the chain.
 - For vacuum sweeping, hook the chain in the holder **Fig. 65-D** with the first link.
 - For attachments with floating position the chain must be hooked onto the hook **Fig. 65-E!**
 3. Check the locking plate **Fig. 65-F** on the attachment. If necessary, loosen the screws and shift the locking plate.
- The following is shown in the multifunction display: Driver not on driver's seat **Fig. 64-X1**; upper end position of the front tool carrier **Fig. 64-X2**; floating position of the front tool carrier **Fig. 64-X3**; front tool carrier lowered and fixed **Fig. 64-X4**.

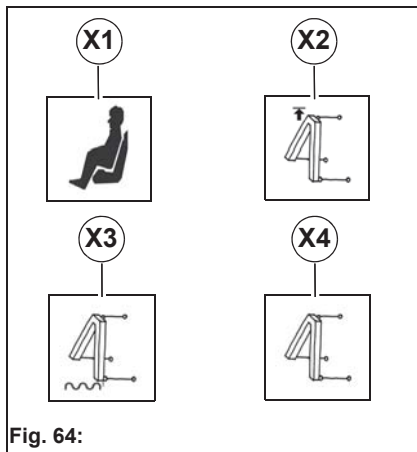

Fig. 64:

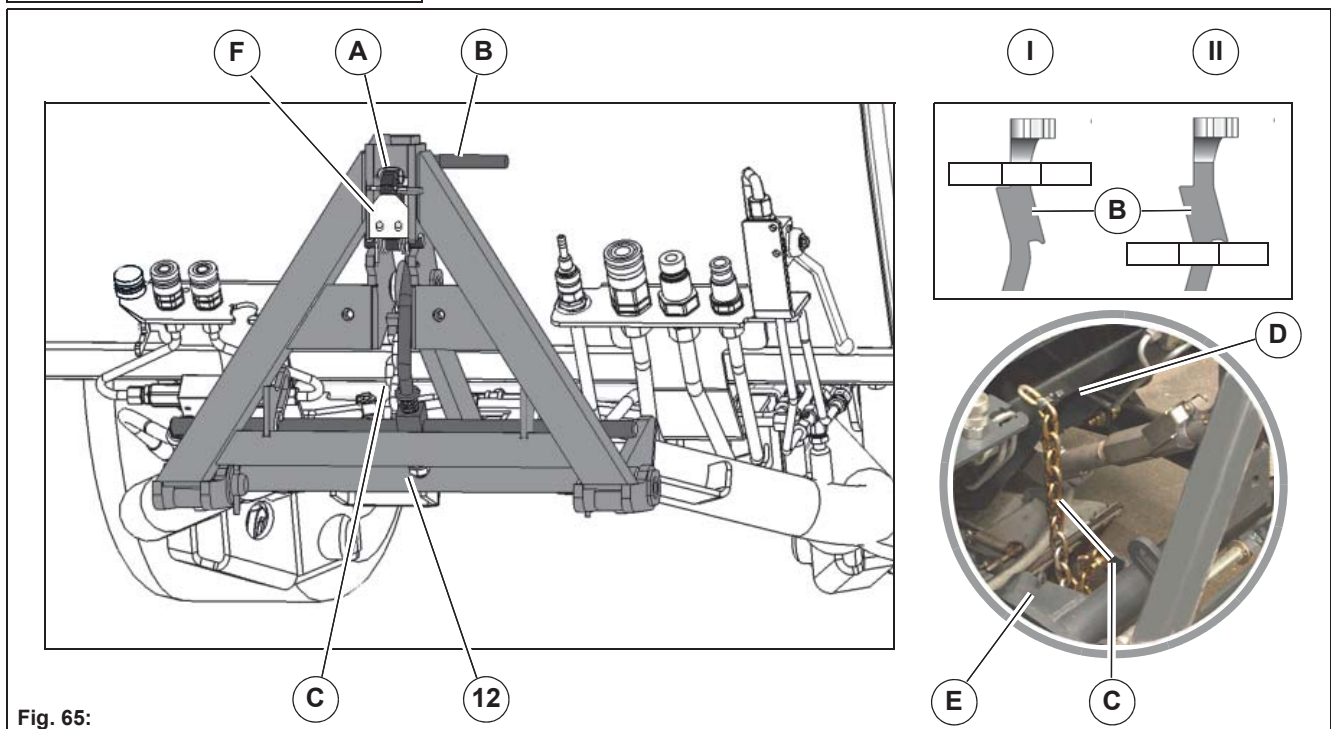

Fig. 65:

Adjustable upper link (optional)

The adjustable upper link **Fig. 66-A** is provided for the fine adjustment of attachments and for simplified take-up of attachments with conventional A-frames type 0. Loosen the nut **Fig. 66-B** and adjust the middle section with a suitable tool to the required length. Then secure with the nut **Fig. 66-B**.

- Turn the middle section clockwise = the front tool carrier inclines to the front
- Turn the middle section counter-clockwise = the front tool carrier inclines to the back

Maximum (I): The spindle touches the edges of the long elongated hole.

Minimum (II): Both spindles are flush.

Standard length (III): The spindle touches the edges of the short elongated hole.

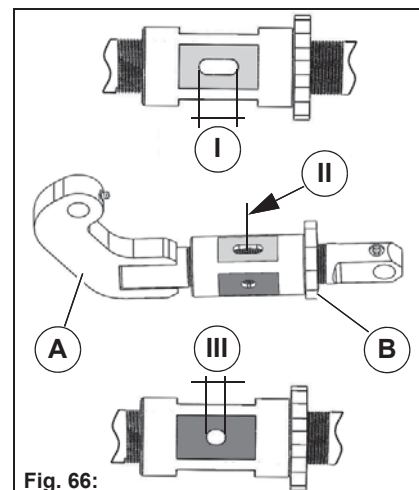

Fig. 66:



Note

When the sweeping system is used, adjustment to position III **Fig. 66** is required for correct operation of the sweeping unit.

Weight holder (optional)

Weight counterbalance **Fig. 67-A** at the tail is required for all heavy front attachments. A weight holder is optionally available. A maximum of six counterweights **Fig. 67-C** (17 kg each) can be hooked into the bars **Fig. 67-B**.

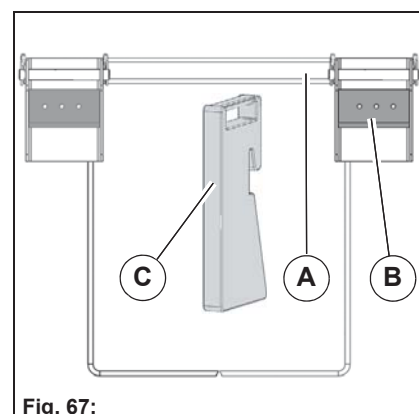

Fig. 67:

Lift system tipper body (optional)

With the optional lift system tipper body, additional controls for raising or lowering the tipper body are located on the left side of the rear wagon.



Danger

Risk of crushing! When carrying out work on the tipper body, always operate the controls in two-handed operation.

- Raise tipper body: Press the button **Fig. 68-A** and the button **Fig. 68-B** simultaneously
- Lower tipper body: Press the button **Fig. 68-A** and the button **Fig. 68-C** simultaneously

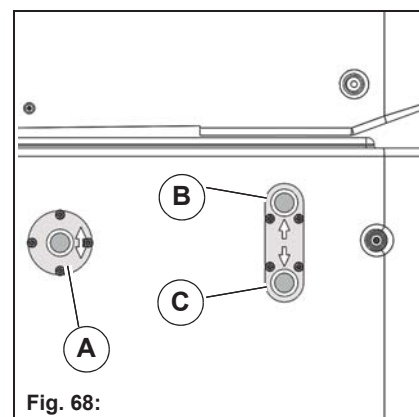

Fig. 68:

2.4.4 Connections for front attachments

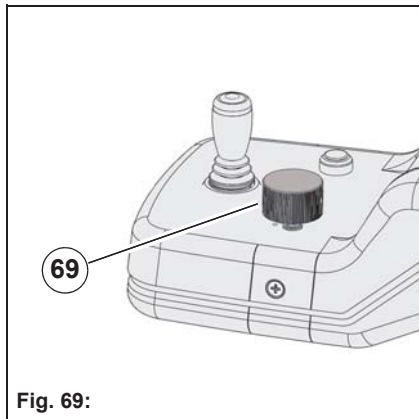

Fig. 69:



Note

The hydraulic couplings are marked with coloured rings and engraving, see example **Fig. 70-A**.

The following devices can be operated with the connections for the front attachments **Fig. 70-12**:

- **A** = Supply for hydraulic cylinder for side adjustment
- **B** = Return for hydraulic cylinder for side adjustment
- **C** = Water connection for sweeping unit spray nozzles
- **D** = Return 25/29/35 l/min (hydraulic circuit I)
- **E** = Supply 25/29/35 l/min (hydraulic circuit I)
- **F** = Return leakage oil pipe (e.g. for mower)
- **G** = Ball cock for locking suction mouth lift (e.g. mower)
- **H** = X63 socket 19-pin for attachments

Switching on the hydraulic circuit

Select the A menu in the multifunction display with the turn-push knob **Fig. 69-69**. Change the current value in the hydraulic circuit I menu item **Fig. 70-X**. Setting range: ON/OFF. Required for attachments without coding plug! The hydraulic circuit is switched off if the driver leaves the driver's seat.

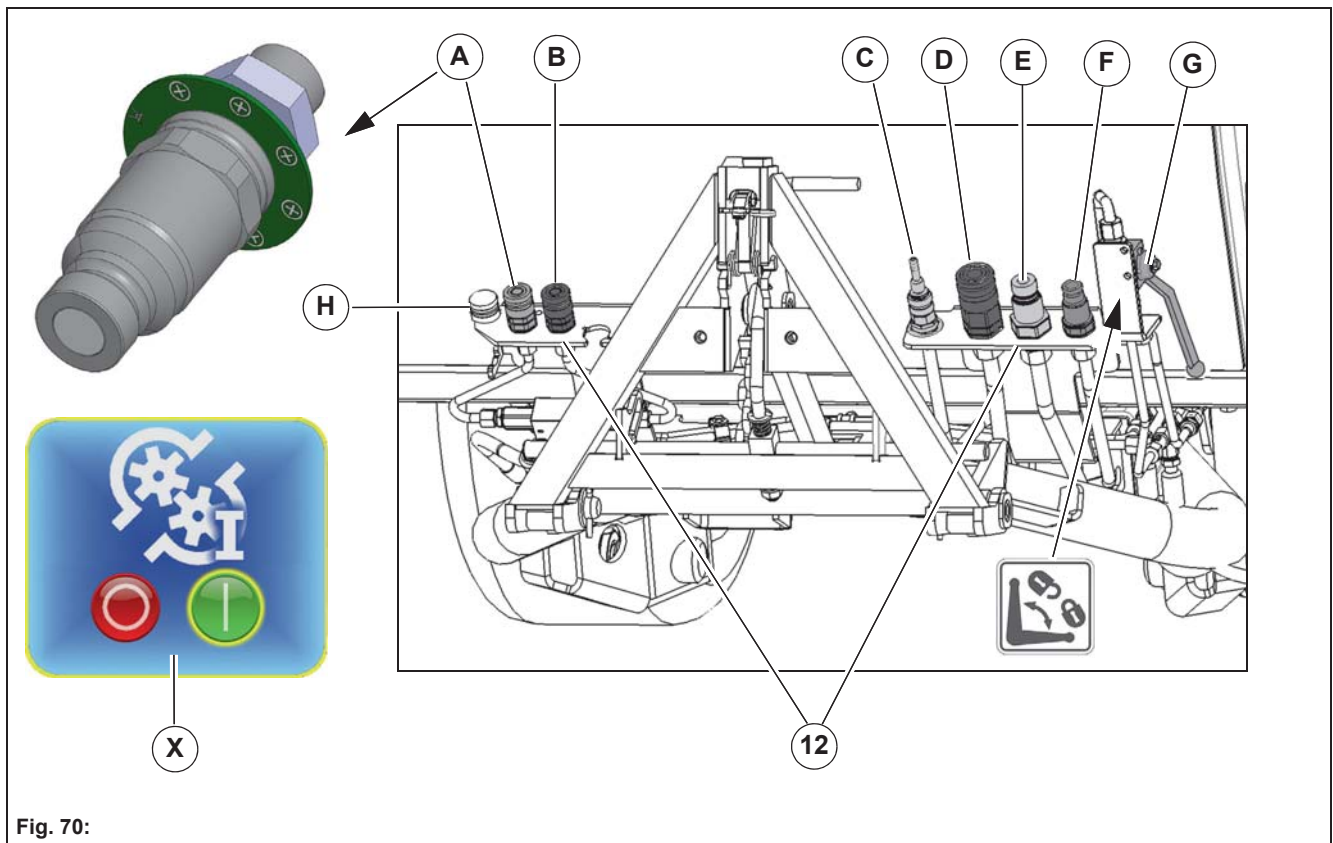

Fig. 70:

2.4.5 Connections for rear attachments



Note

The hydraulic couplings are marked with coloured rings and engraving, see example **Fig. 72-C**.

The following devices can be operated with the connections for the rear attachments **Fig. 72-19**:

- **A** = X64 socket for additional functions of control cable
- **E** = Supply 19/22/27 l/min (hydraulic circuit II)
- **C** = Supply for lift system hydraulic cylinder
- **C** = Return for lift system hydraulic cylinder
- **E** = Return 19/22/27 l/min (hydraulic circuit II)
- **F** = X65 7-pin socket for lighting
- **C** = X68 7-pin socket for spreader control cable
- **C** = X67 7-pin socket for spreader control cable

Switching on the hydraulic circuit

Select the A menu in the multifunction display with the turn-push knob **Fig. 71-69**. Change the current value in the hydraulic circuit II menu item **Fig. 72-X**. Setting range: ON/OFF

Required for attachments without coding plug! The hydraulic circuit is switched off if the driver leaves the driver's seat.

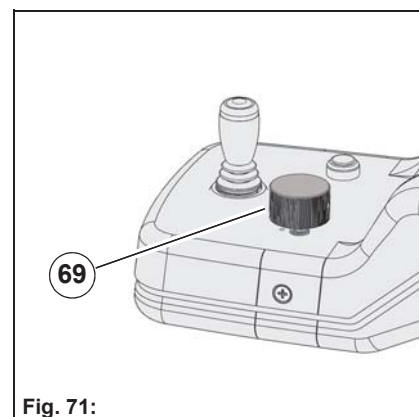

Fig. 71:

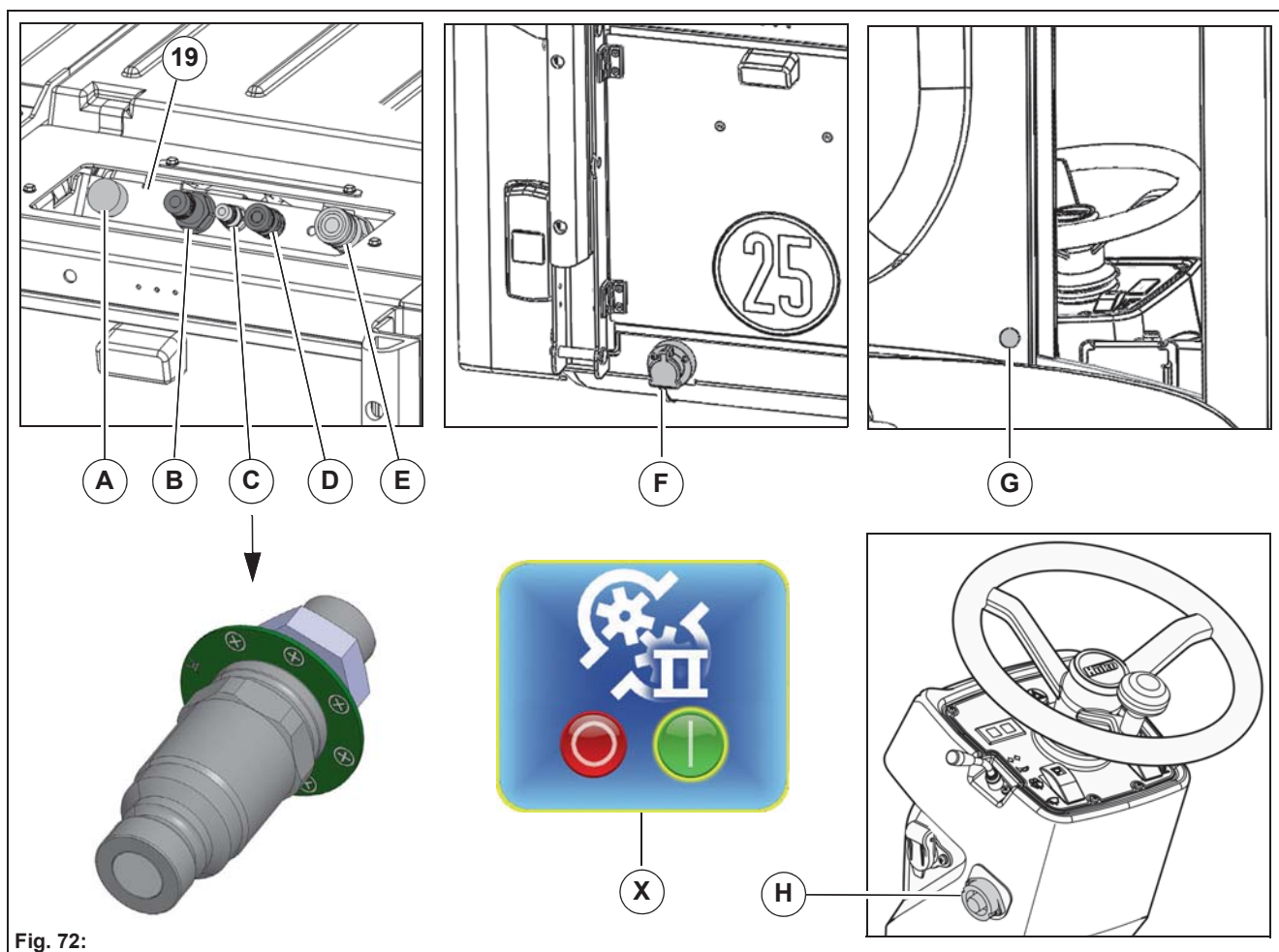

Fig. 72:

3 Operation

3.1 Instruction

Instruction is required before the first start-up.

The first-time instruction of the Citymaster 650 may be provided only by a specialist of your authorised Hako dealer.

This person will be notified immediately after delivery of the vehicle from the factory and will contact you to make an instruction appointment.

3.1.1 Climbing up and down



Danger

Risk of injury when getting on and off from slipping, bumping or catching!

If the access area is heavily soiled or smeared with oil, there is risk of slipping. There is a risk of hitting your head at the cab or clothes getting caught when climbing down.

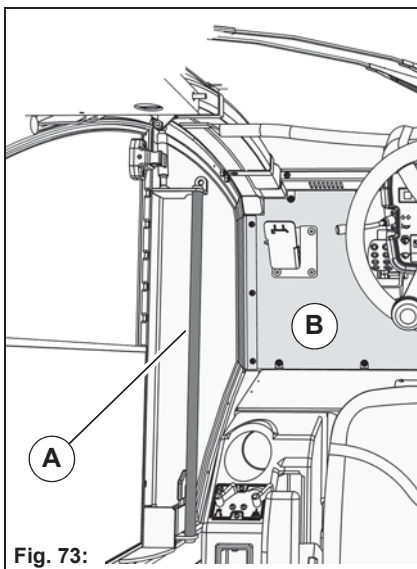

Fig. 73:

Use the door handle to hold on tight when climbing up and down.



Always climb up forward:

1. Open left-hand door and grip and hold the door handle **Fig. 73-A** with your left hand.
2. Put your left foot in the footwell **Fig. 73-B**.
3. Enter the vehicle with your right foot and sit down on the driver's seat.

Always climb down backwards:

1. Use your left hand to get hold of the door handle and hold on tight.
2. Get up from the driver's seat and exit the vehicle with your right foot first.

3.2 Before start-up of the vehicle

	<p>Danger</p> <ul style="list-style-type: none"> • Risk of accident! If the steering column is unlocked while driving, it can come unexpectedly out of adjustment. You can then lose control over the vehicle. • Risk of accident! Adjust the driver's seat only when the vehicle is stationary. You will otherwise be diverted from the traffic and could lose control over the vehicle by moving the seat. You could cause an accident by this. • Risk of accident! A dirty, damaged seat belt or one stressed or changed in an accident may not offer the intended protection. You could therefore suffer severe injuries or death in an accident. Please check regularly that the seat belts are not damaged and not contaminated. Always have damaged seat belts or those stressed in an accident renewed by an authorised workshop. • Risk of accident! Good viewing conditions contributing to traffic safety are guaranteed only if all windows are free of ice, snow and condensation. Make yourself familiar with the correct operation of the heating and ventilation system as well as de-moisturising/defrosting the windows. Maximum heating power and fast thawing of the windows can be achieved only if the engine has reached its operating temperature. • There is a risk of accidents when driving with open doors! The doors must remain closed when driving on public roads and when working.
	<p>Warning</p> <ul style="list-style-type: none"> • Check the vehicle for its correct condition and operating safety before using it. The vehicle must not be used if it is not in order. • Before starting work, the operator must familiarize himself with all equipment, operating and actuating elements as well as with their function. It is too late to do this during operation! • A warning triangle, a warning light, a warning vest and a first aid kit must be in the vehicle during operation. • Sturdy and slip-proof shoes must be worn when working with the vehicle. • This device may not be used by persons (including children) with reduced physical or mental abilities or by persons without sufficient experience and skills. • Carrying persons is not permitted! • Only those surfaces approved by the contractor or its authorised representative for use of the vehicle may be driven on. • The vehicle is not suitable for removing dangerous, combustible or explosive liquids, dusts or materials. • Observe the maximum gradability of the vehicle, see Technical data.

3.2.1 Check-list – Before start-up of the vehicle

No.	Description
1	Checking the locking shackle
2	Checking the fuel supply
3	Checking the engine oil level
4	Checking the hydraulic oil level
5	Checking the coolant level
6	Checking the tyre pressure
7	Checking the windscreen washer unit
8	Checking the lighting system, driver's seat and steering column
9	Checking the outside mirrors

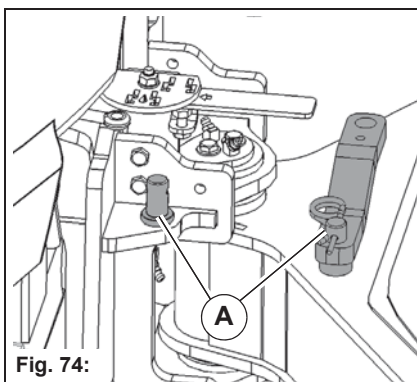

Checking the locking shackle

Before start-up, loosen the locking shackle on the articulated joint **Fig. 74-A** from the locking bolt and bring it into the working position. The vehicle cannot be steered with the locking shackle engaged!



Danger

Staying in the danger area (e.g. in the area of the articulated steering or when coupling attachments and trailers) is not permitted. There is a danger to life!

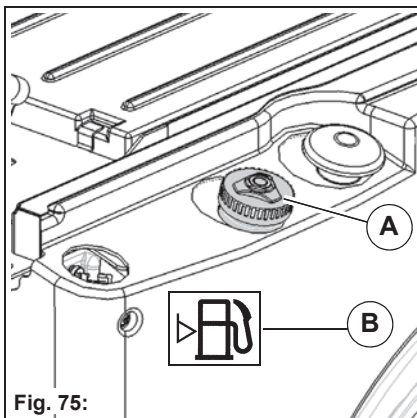

Checking the fuel supply

The current fuel supply is shown in the multifunction display. Refuel as required.

To do this, open the cap **Fig. 75-A**. Filling volume, see Technical data on page 99.

If the warning symbol **Fig. 75-B** appears, then refuel without delay.



Danger

Risk of fire! Diesel fuel is flammable! Take the utmost care when handling fuel. Never refuel close to naked flames or ignitable sparks. Do not smoke during fuelling. Switch off the engine, pull out the ignition key and engage the parking brake before fuelling.

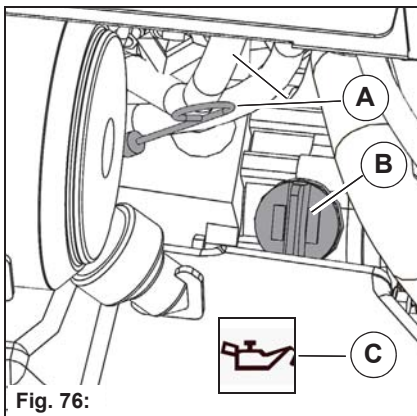

Checking the engine oil level

The oil dipstick **Fig. 76-A** is located behind the service door, on the right-hand side of the rear wagon.

Check the engine oil level with the dip stick. Refill with engine oil if required. To do this, open the cap **Fig. 76-B**. Filling volume, see Technical data on page 99.

If the warning symbol **Fig. 76-C** appears, there is a risk of engine damage. Immediately switch the engine off and check the engine oil level.



Danger

There is a risk of burns and scalds! Caution when handling hot operating and auxiliary materials.

Checking the hydraulic oil level

Check the hydraulic oil level with the level indicator **Fig. 77-A**, if necessary top up hydraulic oil. To do this, open the cap **Fig. 77-B**. Filling volume, see Technical data on page 99.

If the warning symbol **Fig. 77-C/D** appears, there is a risk of hydraulic system operating failure. Immediately switch the engine off and check the hydraulic oil level.

	<p>Danger There is a risk of burns and scalds! Caution when handling hot operating and auxiliary materials.</p>
---	--

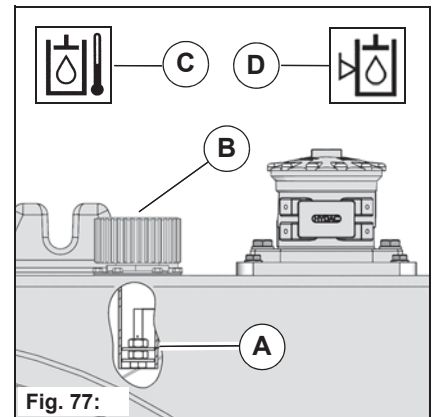

Checking the coolant level

The coolant level of the expansion tank **Fig. 78-A** is also visible from the open service door on the right-hand side and must be between the upper and lower mark **Fig. 78-B**.

Top up the coolant if necessary. To do this, open the cap **Fig. 78-C**. Filling volume, see Technical data on page 99.

If the warning symbol **Fig. 78-D** appears, there is a risk of engine damage. Immediately switch the engine off and check the coolant level.

	<p>Danger There is a risk of burns and scalds! Caution when handling hot operating and auxiliary materials.</p>
---	--

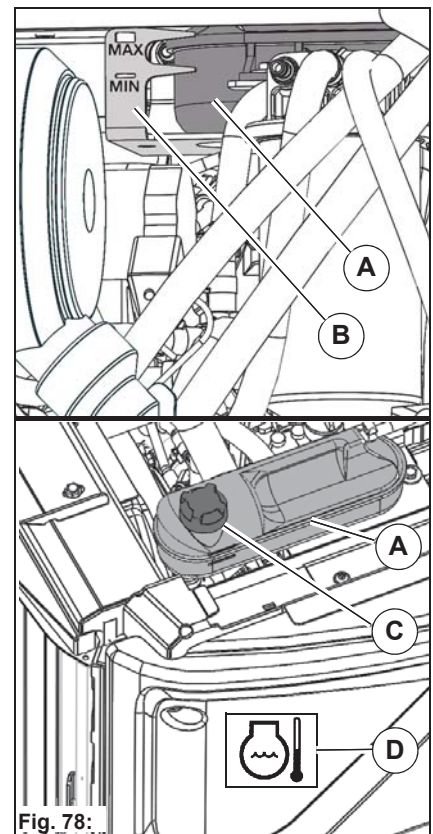

Checking the tyre pressure

Remove the valve cap **Fig. 79-A** and adjust the tyre pressure with a compressed air unit, see Technical data on page 99.

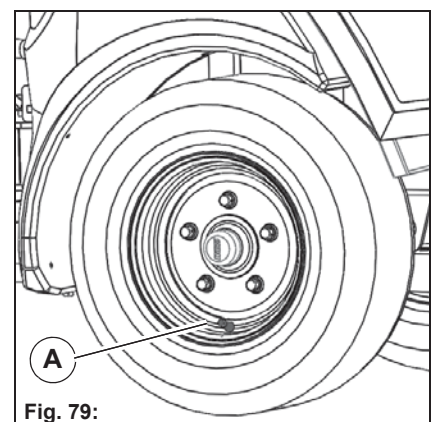

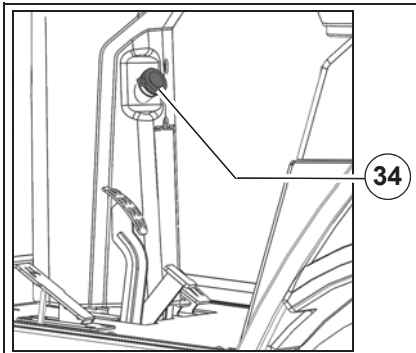
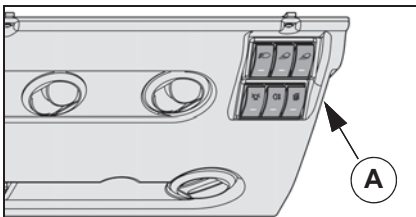

Fig. 80:

Checking the windscreen washer unit

Fill the windscreen washer unit tank **Fig. 80-34**. Filling volume, see Technical data on page 99.



Checking the lighting system

Check all lighting equipment on the vehicle with the switches **Fig. 81-A** on the control panel in the roof and the direction indicator in the steering column.

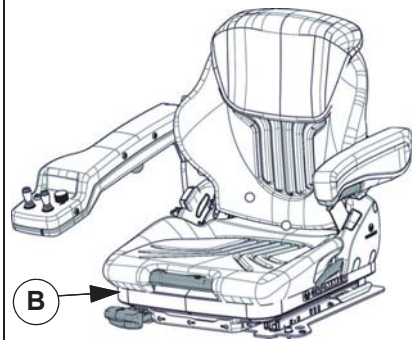

Checking the driver's seat and steering column

Adjust the driver's seat **Fig. 81-B** and the steering column **Fig. 81-C** in such a way that all controls can be easily reached.



Fig. 81:

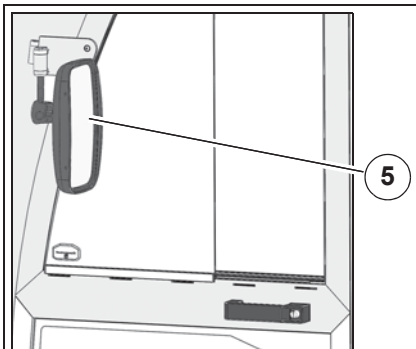

Fig. 82:

Checking the outside mirrors

Adjust the outside mirrors **Fig. 82-5**. Adjust the outside mirrors so that the roadway and the rear work area are completely visible.

3.3 Starting and driving the vehicle



Danger

- Toxic engine exhaust gases! Inhaling exhaust gases is injurious to health and can lead to unconsciousness and to death! Never let the engine run in enclosed spaces.
- Danger to life in the danger area of the vehicle! Special caution is required under the raised tipper, in the area of the front and rear attachment and in the area of the trailer.
- Danger of tilting over when driving uphill or downhill and transversely to a slope! Avoid sudden turns when driving uphill or downhill or across slopes. There is a risk of tilting over in an inclined position! The vehicle speed must always be adapted to the surrounding conditions and the load condition.
- Danger of tilting due to wrong steering! Note that the steering behaviour of an articulated steered vehicle differs essentially from that of a car. Sudden steering movements at high speed or too high speeds when turning can cause the vehicle to tilt over.
- Risk of accident! Note that there is a risk of skidding on unpaved ground or snow and ice. This can lead to uncontrolled behaviour of the vehicle. Drive correspondingly carefully!

Warning

- For reasons of safety, the vehicle is equipped with a seat contact switch and the function of the seat contact switch must not be bypassed.
- In the case of restricted vision, especially when reversing the vehicle, it is necessary to have a second person who gives the driver appropriate signals. The second person must always be in the field of view of the driver.
- When working with the vehicle, pay special attention to third persons, especially children.
- In transport journeys on public roads the working lights must be switched off.

Attention

- If the engine oil pressure warning symbol **Fig. 98-A** in the multifunction display lights up with the engine running, there is a risk of engine damage! Stop the vehicle in the safe range. Turn the engine off immediately and check the oil level. Have the cause of the inadequate engine oil pressure removed.

3.3.1 Starting and driving the vehicle

No.	Description	Reference
1	Accelerator pedal in zero position	Page 84
2	Engaging parking brake	Page 84
3	Starting engine and releasing parking brake	Page 85
4	Starting transport mode	Page 85
5	Activating work mode	Page 86
6	Setting engine fixed speed for attachments/options	Page 86
7	Activating front tool carrier	Page 86

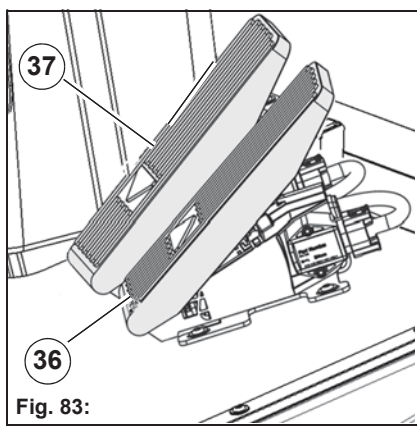

Accelerator pedal in zero position

The accelerator pedals **Fig. 83-36** and **Fig. 83-37** must be in the zero position to start the engine.

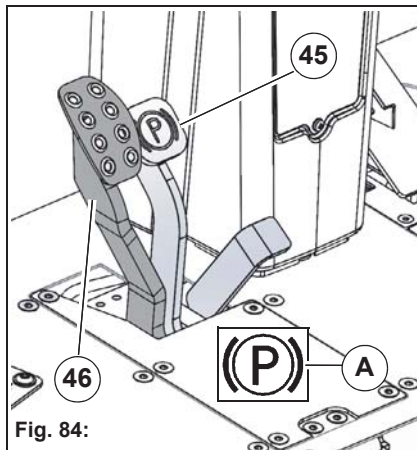

Engaging parking brake

The parking brake **Fig. 84-45** stops the vehicle from rolling away. First press the brake pedal **Fig. 84-46** and then the parking brake with your foot. The parking brake is locked. The parking brake warning symbol **Fig. 84-A** appears in the multifunction display.

Starting the engine

	<p>Note Before starting the engine, depress the brake pedal!</p>
---	---

Start the engine with the ignition switch **Fig. 85-76**.

- Position 1: Preheat the engine until the control light **Fig. 85-A** goes out.
- Position 2: Start the engine.
 - The ignition switch goes back into position 1.

Note the information on the ignition switch on page 64.

Releasing the parking brake

Press the brake pedal **Fig. 84-46** without operating the parking brake **Fig. 84-45**.

Starting transport mode

Slowly press down the accelerator pedal **Fig. 86-36** or **Fig. 86-37** for the required direction and speed. The vehicle moves away. Engine speed in transport mode = 1100 to 2630 rpm. The corresponding engine speed and the transport mode information symbol **Fig. 86-A** appear in the multifunction display.

The speed in the transport mode is 0 to 25 km/h.

When the accelerator pedal is released (forwards or reverses) the vehicle comes to a stop quickly because of the hydrostatic braking effect.

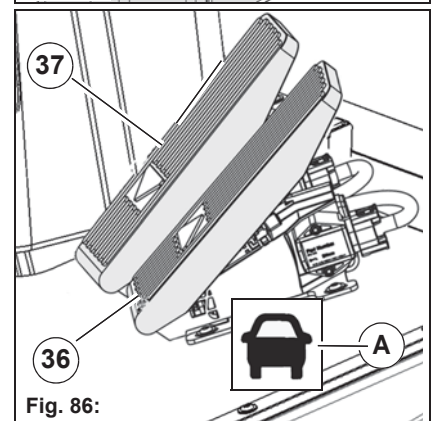
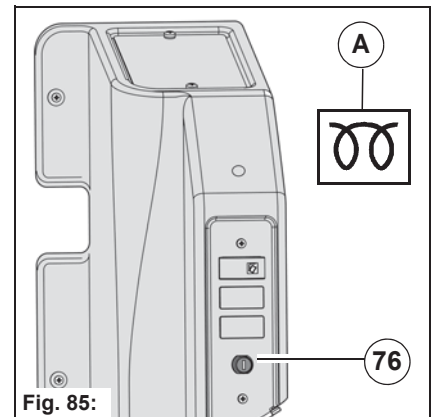

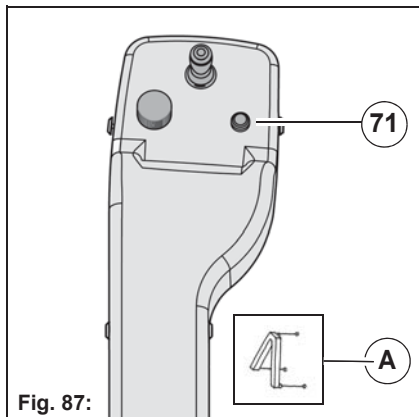

Fig. 87:

Activating work mode

Use the Hako button **Fig. 87-71** to change over from transport mode to work mode.

The accelerator pedals must be in the neutral position.

The work mode with front tool carrier information symbol **Fig. 87-A** appears in the multifunction display.

The driving speed in the work mode is 0 to 25 km/h.

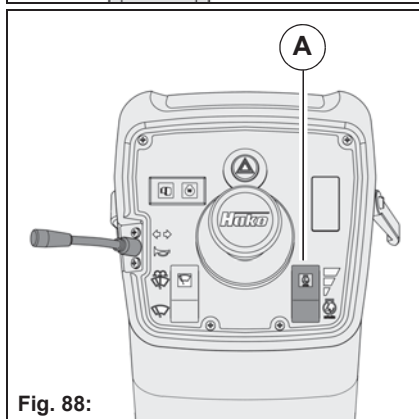

Fig. 88:

Setting engine fixed speed for attachments/options

The engine speed for attachments or options is set with the switch **Fig. 88-A**. Set the speed according to the requirements.

Stage	rpm	Front attachment: l/min	Rear attachment: l/min
1 – ECO	1900	25	19
2 – Standard	2250	29	22
3 – Maximum	2630	35	27

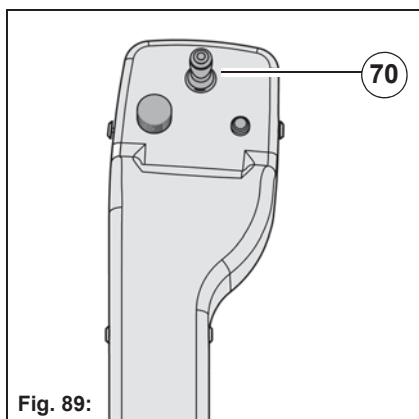

Fig. 89:

Activating the front tool carrier

The front tool carrier is activated with the joystick **Fig. 89-70**. The following functions are possible for a vehicle without attachment:

- Raising front tool carrier
- Lowering front tool carrier (floating position)

The function of the joystick with an attachment is described in chapter 6. Raising the front tool carrier is interrupted if the driver leaves the driver's seat.

3.3.2 Diesel particle filter

	<p>Danger</p> <ul style="list-style-type: none"> • Danger of fire and burning! The diesel particulate filter gets very hot. Do not grasp in the area of the diesel particulate filter. Do not park the vehicle in the direct vicinity of flammable substances. <p>Attention</p> <ul style="list-style-type: none"> • If the diesel particulate filter symbol (regeneration requested) Fig. 90-A lights up yellow in the multifunction display and is ignored, this may cause damage to the diesel particulate filter!
---	--

The vehicle is equipped with a diesel particulate filter. The diesel particulate filter (DPF) filters soot particles from the exhaust gas. During regular regeneration, the accumulated soot particles are burned at high temperatures.

Depending on how high the soot concentration in the diesel particulate filter is, the following modes are provided by the engine control unit:

- Automatic regeneration
- Manual regeneration

Automatic regeneration

The automatic regeneration starts automatically and runs smoothly during work. This mode is used for normal soot concentration. During regeneration, it is warned of hot exhaust gases. The diesel particulate filter (hot exhaust gases) information symbol **Fig. 90-B** appears in the multifunction display.

If the current situation does not allow it, automatic regeneration can also be disabled. However, the lock should be removed as soon as possible to prevent damage to the diesel particulate filter!

- Use the turn-push knob **Fig. 90-69** to switch from the normal view to the configuration menu and call up the diesel particulate filter setting sub-menu.
 - Use the turn-push knob to set the value **Fig. 90-D** to ON.
- The diesel particulate filter (regeneration locked) information symbol **Fig. 90-C** appears in the multifunction display.



Fig. 90:



Manual regeneration

The manual regeneration must be started by the operator. This mode is used for increased soot concentration.

The diesel particulate filter (regeneration required) information symbol **Fig. 91-A** appears in the multifunction display.

Use the turn-push knob **Fig. 90-69** to switch from the normal view to the configuration menu and call up the diesel particulate filter menu.

The following conditions must be fulfilled for regeneration:

- The parking brake has been applied
- The engine is switched on and transport mode has been selected
- Temperature > 10 °C
- Regeneration lock has been switched off

If all the conditions have been fulfilled, the symbols **Fig. 91-B** light up green. The regeneration can be started. Use the turn-push knob to select the **START** symbol **Fig. 91-C**.

During regeneration, the progress is indicated by a yellow bar. If the exhaust gas temperatures rise, the diesel particulate filter (hot exhaust gases) information symbol **Fig. 91-D** appears. A green bar is displayed once regeneration has been completed.

Use the turn-push knob to select the **EXIT** symbol and switch back to the normal view.



Note

For uninterrupted manual regeneration, note the following:

- Do not change the speed
- Leave the accelerator pedals in neutral position
- Do not release the parking brake
- Do not use the vehicle during manual regeneration

Non-observance leads to premature termination of regeneration.

Fig. 91:

3.3.3 Troubleshooting

The engine does not start, the starter works audibly.	Remedy
The engine electronics are faulty. The fuel supply is faulty.	Do not repeat the starting procedure more than 3 times, then let the starter cool down. If the engine does not start even after several starting attempts: Notify an authorised workshop.
The engine does not start, the starter is not audible.	Remedy
The electrical system voltage is too low because the battery is too weak or empty.	Have starting help applied. If the engine does not start despite starting help: Notify an authorised workshop.
The starter was exposed to too high thermal loading.	Let the starter cool down for around 2 minutes. Start the engine again. If the engine still does not start: Notify an authorised workshop.

3.4 Shutting down the vehicle

	<p>Danger</p> <ul style="list-style-type: none">• Risk of accident! Adopt measures against erroneous starting and unwanted movement. Engage the parking brake. Switch the engine off and pull out the ignition key.• Risk of accident! The vehicle must be parked on firm ground. On inclinations secure the vehicle additionally against rolling away with a wheel chock. <p>Attention</p> <ul style="list-style-type: none">• Do not switch the engine off in normal operating condition from the high speed range, only in the case of faults.• After full load operation, let the engine idle on for 1 to 2 minutes.• Do not switch the engine off when an attachment is switched on.
---	--

3.4.1 Shutting down after the end of work

1. Bring the accelerator back into the neutral position or take your foot off from the accelerator pedal. The hydrostatic drive brakes to standstill.
2. Engage the parking brake.
3. Switch the engine off and pull out the ignition key.
4. Close the driver's cab if necessary.

3.4.2 Shutting down in work breaks

The driver must also bring all operating devices into zero position even in short work breaks before leaving the vehicle. Engage the parking brake and secure it against unauthorised use.

3.4.3 Shutting down on occurrence of faults

The engine of the Citymaster 650 must be switched off immediately on the occurrence of faults. A vehicle left lying on public roads must be secured with the hazard warning system and warning triangle. If the electrical system has failed, the vehicle must be secured with the warning light.

3.5 Transporting and towing the vehicle



Warning

- Danger to life! Start driving slowly! Make sure that there are no persons in the towing area.
- Risk of injury! The vehicle may be loaded only using suitable loading aids, such as a loading ramp or drive-up planks.
- Risk of injury! After loading, make sure that the vehicle is secured according to regulations against rolling off and tilting. Use the wheels for securing the vehicle.

Warning

- Tow the vehicle using only suitable towing gear!
- The vehicle may be towed with a towing rope only if the brakes and steering are functioning!
- When the engine is still the steering has only emergency steering properties!
- Secure the vehicle against unintended movement! Lock the parking brake and insert the locking strap on the articulated joint. Note that the steering is then blocked!

Attention

- The towing speed may be at most 2 km/h, the towing time at most 30 minutes and the towing distance at most 1 km!

3.5.1 Transporting the vehicle

Securing the vehicle

- Place a wheel chock diagonally before and behind any front or rear wheel.
- Additional security by one three-point belt each.

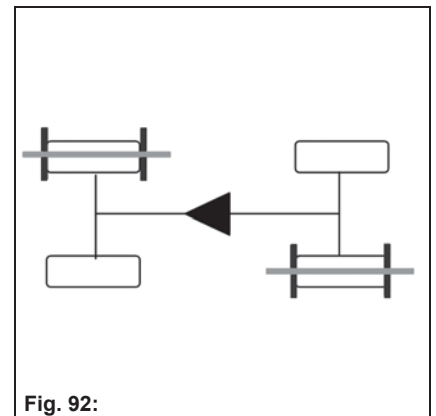

3.5.2 Towing the vehicle

Opening the bypass valve

The wheels are blocked when the vehicle is at a standstill. Should it be necessary for you to tow or move the vehicle, you must open the bypass valve **Fig. 93-A**.

- Bypass valve lever in position **B** = valve closed
- Bypass valve lever in position **C** = valve opened

Towing eye

The towing eye **Fig. 93-D** is located in the rear wagon and must be fitted to the front tool carrier **Fig. 93-12**.

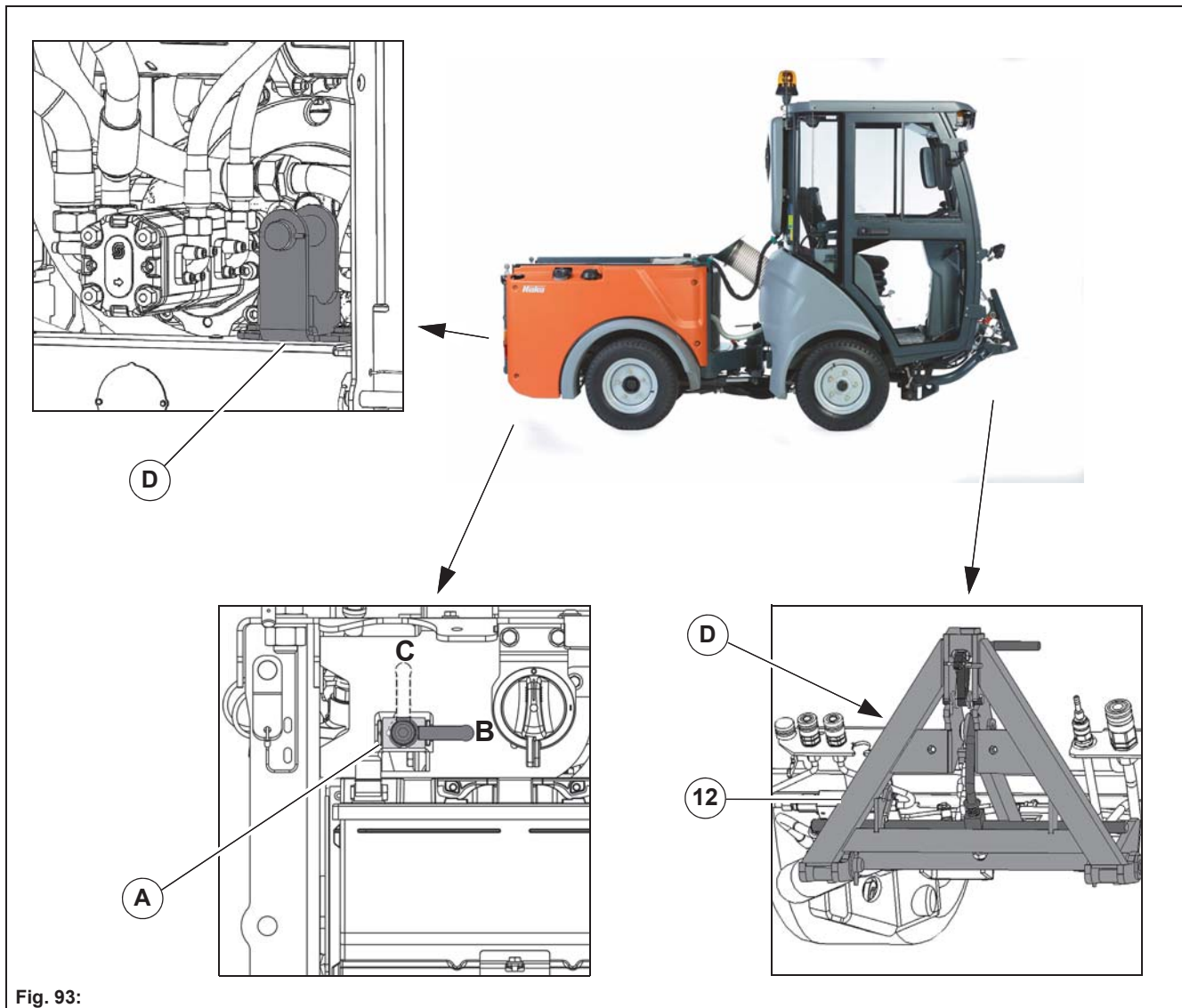



Fig. 93:

3.6 Working with attachments

**Danger**

- Danger to life in the danger area of the vehicle! Special caution is required under the raised tipper, in the area of the front and rear attachment and in the area of the trailer.
- Risk of injury! Put the attachment into service only if all protective devices are attached and in protection position.
- Risk of injury! Make sure that the attachments are suitable for the set oil volume. An oil volume set too high can lead to injuries due to a defect of the attachment!
- Risk of injury! High-pressure hoses, fittings and couplings are important for equipment safety. Use only high-pressure hoses, fittings and couplings recommended by the manufacturer.
- Risk of accident! When connecting attachments to the hydraulic system, ensure that the hydraulic hoses are connected correctly. Swapping the connections can lead to reverse functioning of the attachment, e.g. movement to the right rather than the left.
- Risk of accident! Front attachments not correctly fastened to the front tool carrier can drop down while driving. Always secure the front attachment with the locking devices.
- Risk of accident! You must consult Hako before attaching other attachments not approved by Hako! Check in the individual case that the relevant axial loads and total weights are complied with.
- Risk of accident! Handling, steering and braking as well as stability are influenced by attachments, trailers and the vehicle payload (e.g. full dirt hopper). For this reason, pay attention to adequate steering and braking capability as well as stability.
- Risk of accident! In Germany, if attachments extend beyond the outer lighting equipment of the vehicle or if the maximum distances of the outer lighting equipment specified according to StVZO are exceeded, the lighting equipment of the vehicle must be repeated (see Merkblatt StVZO § 30, explanations 11 and 12).

3.6.1 Ballast

	<p>Danger</p> <ul style="list-style-type: none"> • Risk of accident! When attaching other devices not approved by Hako, check in the individual case whether the relevant axle loads and total weights are complied with! • Risk of accident! The front axle of the working machine must always be loaded with at least 21 % of the empty weight and the rear axle with at least 42 % of the empty weight of the working machine. • Risk of accident! The front and rear attachments must not lead to exceeding the permissible total weight, the permissible axle load and the tyre load capacity of the working machine! <p>Warning</p> <ul style="list-style-type: none"> • Make sure before purchasing the attachment that these requirements are fulfilled by weighing the working machine attachment combination!
---	---

Calculating ballast

You require the following data to calculate the total weight, the axle loads and the tyre load capacity as well as the required minimum ballast:



Note

All weight data in (kg).
All dimensions in (m).

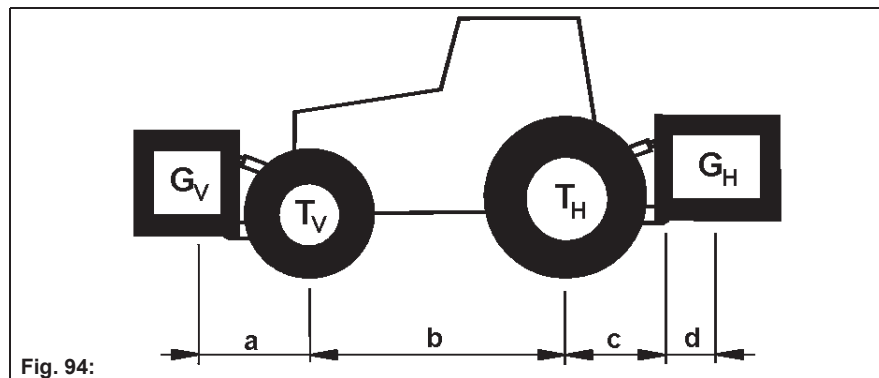

- T_L (kg) = empty weight of the vehicle (1)
- T_V (kg) = front axle load of the empty vehicle (1)
- T_H (kg) = rear axle load of the empty vehicle (1)
- G_H (kg) = total weight of rear attachment/rear ballast (2)
- G_V (kg) = total weight of front attachment/front ballast (2)
- a (m) = distance between centre of gravity of front attachment (front ballast) and middle of front axle max. = 1,565 m (2 and 3)
At maximum front ballast 180 kg.
- b (m) = vehicle wheelbase (1 and 3)
- c (m) = 0.796 m
- d (m) = distance between middle of attachment-side fixing point and centre of gravity of rear attachment/rear ballast max. 0.175 m (2 and 3)
At maximum rear ballast 400 kg.

1. See Citymaster 650 technical data.
2. See price list and/or operating manual of the attachment.
3. Measure.

1 Calculation of the minimum front ballast for rear attachments

$$G_{V \min} = \frac{G_H \times (c+d) - T_V \times b + 0,2 \times T_L \times b}{a+b}$$

Enter the value in the table.

2 Calculation of the minimum rear ballast for front attachments

$$G_{H \min} = \frac{G_V \times a - T_H \times b + x \times T_L \times b}{b+c+d}$$

(Value "x" see manufacturer's data, if no information x = 0.45)

Enter the value in the table.

3 Calculation of the actual front axle load $T_{V \text{tat}}$

If the required minimum front ballast ($G_{V \min}$) is not reached, with the front attachment (G_V), the weight of the front attachment must be increased to the weight of the minimum front ballast!

$$T_{V \text{tat}} = \frac{G_V \times (a+b) + T_V \times b - G_H \times (c+d)}{b}$$

Enter the calculated actual front axle load and the permissible front axle load stated in the operating manual of the work machine in the table.

4 Calculation of the actual total weight

(If the required minimum rear ballast ($G_{H \min}$) is not reached with the rear attachment (G_H), the weight of the rear attachment must be increased to the weight of the minimum rear ballast!)

$$G_{\text{tat}} = G_V + T_L + G_H$$

Enter the calculated actual total weight and the permissible total weight stated in the operating manual of the work machine in the table.

5 Calculation of the actual rear axle load

$$T_{H \text{tat}} = G_{\text{tat}} - T_{V \text{tat}}$$

Enter the calculated actual rear axle load and the permissible rear axle load stated in the operating manual of the work machine in the table.

6 Tyre load capacity

Enter double the value (two tyres) of the permissible tyre load capacity (see for example documents of the tyre manufacturer) in the table.

Ballast table

The calculated values must be less than or equal to the permissible values!

	Actual value according to calculation		Permissible value according to operating manual		
Front/rear minimum ballast	kg	\leq			
Total weight	kg		kg		
Front axle load	kg	\leq	kg	\leq	kg
Rear axle load	kg	\leq	kg	\leq	kg

The minimum ballast must be attached to the vehicle as attachment or ballast weight!

Mounting the ballast weight

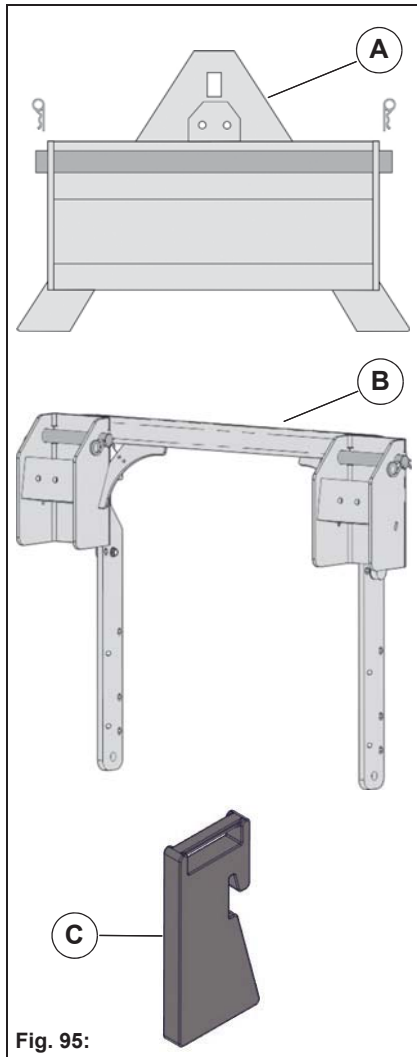

Fig. 95:

The following accessories are available for ballast:

Accessories	Type
Front weight holder for max. 9 ballast weights	344000
Rear weight holder for max. 6 ballast weights	344110
Ballast weight 17 kg	343900

Fit a sufficient number of ballast weights **Fig. 95-C** to the weight holder **Fig. 95-A** or **Fig. 95-B** and secure with retaining bolts and split pins.

4 Technical data

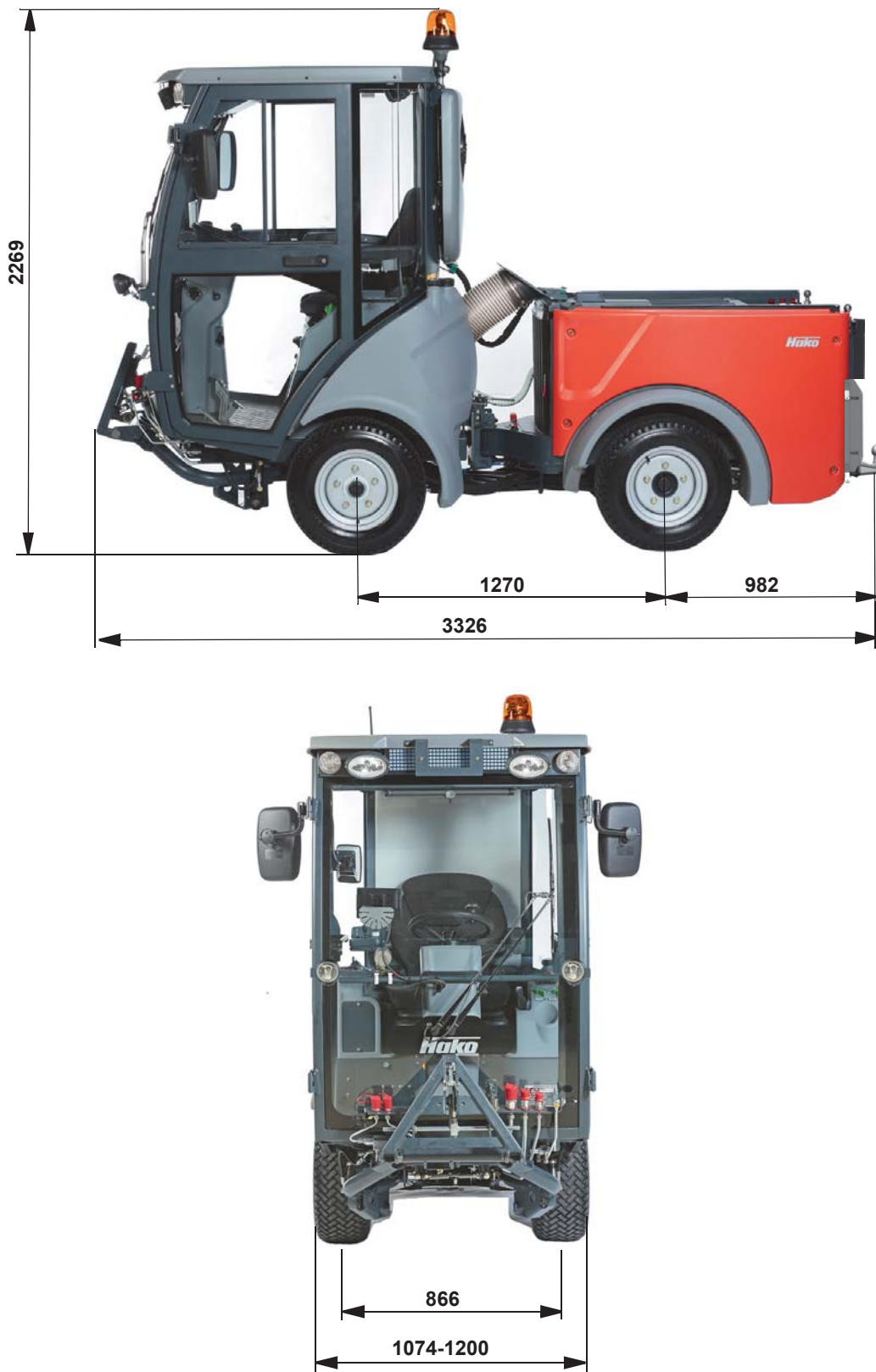

Fig. 96:

Technical data

Dimensions

Name	Unit	
Length	mm	3326
Width (according to tyres)	mm	1074-1200
Height	mm	2269
Wheelbase	mm	1270
Tread width	mm	866
Turning circle (DIN EN 15429-1)	mm	4080

Weights and loads

Name	Unit	
Empty weight of basic vehicle	kg	1430
Permissible total weight	kg	2200
Permissible total combination weight unbraked	kg	2700
Permissible total combination weight braked	kg	3950
Permissible front axle load	kg	1200
Permissible rear axle load	kg	1500
Permissible supporting load in the coupling point of the jaw coupling	kg	150
Permissible supporting load in the coupling point of the ball head coupling	kg	150

Driving speeds and inclination values

Name	Unit	
Transport mode/work mode forwards	km/h	25
Transport mode/work mode reverse	km/h	10
Gradability basic machine in work mode (forwards/reverse)	%	25
Gradability trailer operation at permissible total combination load braked (forwards/reverse)	%	15

Noise emission values – basic vehicle

Driving noise according to (EU) Regulation 2018/985 is:	79 dB(A)
Standing noise according to (EU) Regulation 2018/985 is:	78 dB(A)
Noise at driver's ear according to (EU) Regulation 1322/2014 is:	80 dB(A)

Vibration values – basic vehicle

The weighted effective value of the acceleration to which the body (feet or seat surface) is subjected to according to EN 1032 is under the customary conditions of use no more than:	0.5 m/s ²
---	----------------------

Engine

Manufacturer		Yanmar
Type		3TNV88C-KHW
Number of cylinders		3
Displacement	cm ³	1642
Power	kW	25.5
Speed	rpm	2630
Torque	Nm	105
Engine oil volume	litre	6.7
Cooling water volume	litre	7.5

Fuel system

Fuel		Diesel
Tank volume	litre	40

Hydraulic system

Hydraulic oil		HVLP 46
Tank volume	litre	35
Lifting power of front tool carrier with clearance = 0 mm/600 mm	N	5000/3000

Tyres

Standard tyres: Trelleborg 23x8.5-12TT 10PR T539	Tyre inflation pressure in bar Front: 1.9 / Rear: 2.7	Load capacity in kg 600/750
Wide tyres: Optional Trelleborg 23x10.5-12TL 6PR T539	Tyre inflation pressure in bar Front: 1.5 / Rear: 2.0	Load capacity in kg 600/750
Wide tyres: Optional Vredestein 270/50-12	Tyre inflation pressure in bar Front: 1.3 / Rear: 2.1	Load capacity in kg 600/750

Pay attention to the installation inflation pressure when fitting the tyres! This may be a maximum of 1.5 times the tyre inflation pressure.

Electrical system

Starter		Yanmar DC12V
Nominal voltage	Volt	12
Generator		Bosch 12V-80A

Windscreen washer unit

Tank volume	litre	2.0
-------------	-------	-----

5 Maintenance and Servicing

General



Note

Before undertaking servicing and maintenance work, read and observe the safety instructions in chapter 1 of this operating manual.

Compliance with the maintenance work recommended by us gives you the certainty of always having an operational vehicle available.

Daily and weekly maintenance and repair work can be undertaken by a driver trained for this purpose. In all other maintenance work, see service booklet, contact your nearest authorised Hako dealer.

Any warranty claim is null and void if this is not complied with and damage results.

Please always state the serial number in all enquiries and spare parts orders, see the Labels on the vehicle section.

5.1 Maintenance plan

Maintenance plan – daily
Vehicle cleaning <ul style="list-style-type: none"> • Vehicle cleaning as required
Engine <ul style="list-style-type: none"> • Checking engine oil level, replenishing if necessary • Checking and if necessary refilling coolant level in expansion tank • Checking combination radiator and radiator grille for dirt, cleaning with compressed air if necessary • Checking fuel supply, refuelling if required • Checking maintenance indicator of the air filter, cleaning filter elements if necessary
Steering <ul style="list-style-type: none"> • Checking the emergency steering function
Brake <ul style="list-style-type: none"> • Checking the operating and parking brakes for function
Electrical system <ul style="list-style-type: none"> • Checking lighting, work functions, horn, etc.

Maintenance plan – weekly
Vehicle cleaning <ul style="list-style-type: none"> • Vehicle cleaning as required
Engine <ul style="list-style-type: none"> • Checking engine oil level, replenishing if necessary • Checking and if necessary refilling coolant level in expansion tank • Checking combination radiator and radiator grille for dirt, cleaning with compressed air if necessary • Checking fuel supply, refuelling if required • Checking maintenance indicator of the air filter, cleaning filter elements if necessary • Emptying the water trap of the fuel system
Cab <ul style="list-style-type: none"> • Checking the windscreen washing agent level, refilling if necessary • Checking air conditioning system for function • Checking heating for function
Steering <ul style="list-style-type: none"> • Checking the emergency steering function • Checking steering cylinder for play
Brake <ul style="list-style-type: none"> • Checking the operating and parking brakes for function • Braking test
Hydraulics <ul style="list-style-type: none"> • Checking the hydraulic oil level, refilling if necessary
Lubrication service (see section 5.11) <ul style="list-style-type: none"> • Door hinges (4x) • Front lifting cylinder (4x) and front lift system (2x) • Coarse material flap (1x), articulated joint (4x) and steering cylinder (1x)
Tyres <ul style="list-style-type: none"> • Checking the air pressure of the tyres

5.2 Panelling and covers



Danger

- Risk of injury! Put the attachment into service only if all protective devices are attached and in protection position.
- Danger of burns from hot parts! Do not touch any parts such as engine block, cooling system and exhaust system during operation and for some time after. Let the engine cool down.

5.2.1 Removing the engine cover

Open the lock **Fig. 97-A** with a square key and pull the engine cover **Fig. 97-B** out in travel direction and upwards.

5.2.2 Opening the side panelling on the left and right

Side panelling on the left: Loosen the four fastening bolts **Fig. 97-C** and remove the side panelling **Fig. 97-D**.

Side panelling on the right: Open the two top lock fasteners **Fig. 97-E**, raise the catch **Fig. 97-F** and swivel open the service door **Fig. 97-G**. To remove, release the safety cable **Fig. 97-H** and unhook it from the hinges.

5.2.3 Removing radiator cover

Pull the lever **Fig. 97-I** to the front and remove the radiator cover **Fig. 97-J** to the side and front.

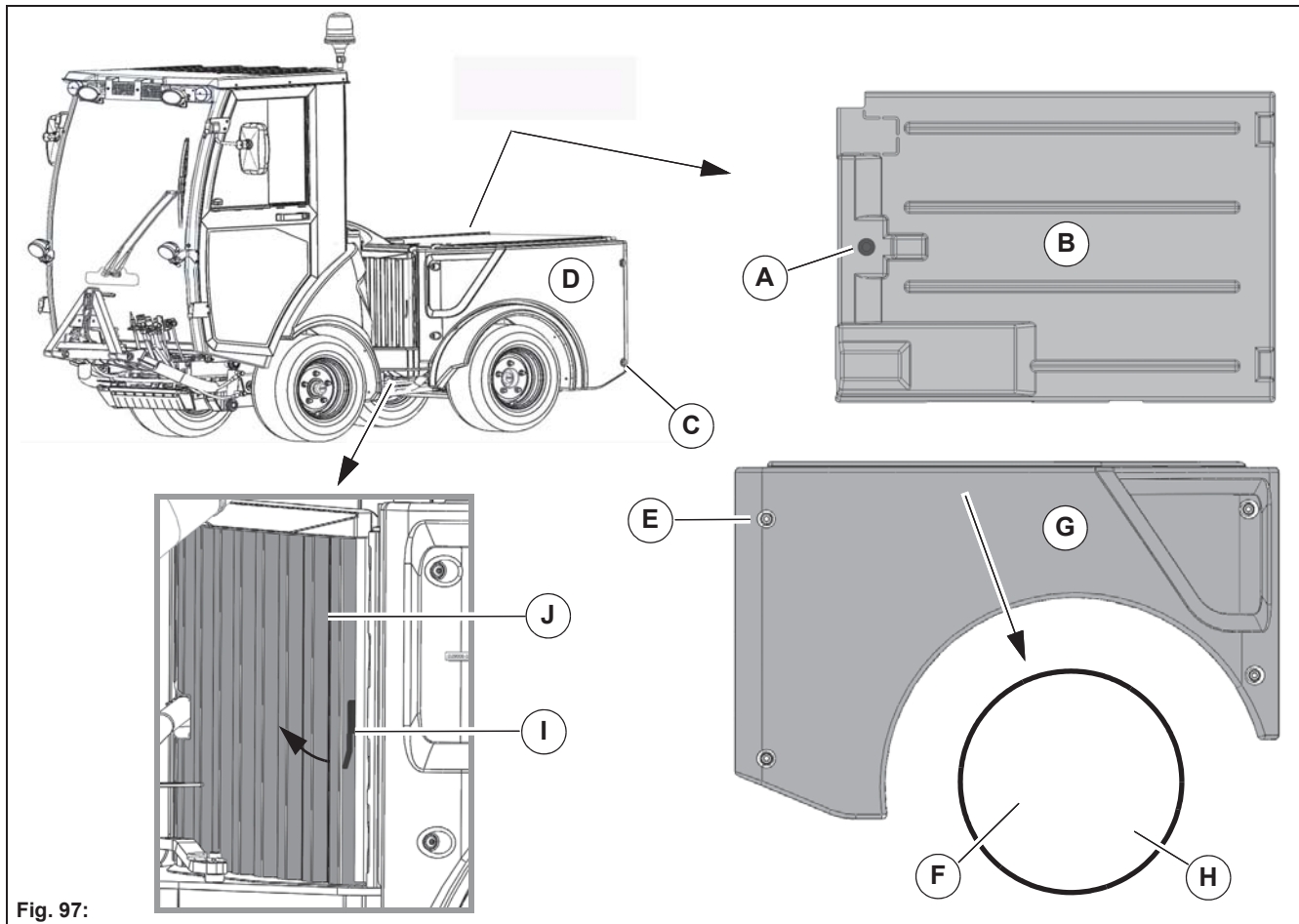

Fig. 97:

5.3 Engine



Danger

- Toxic engine exhaust gases! Inhaling exhaust gases is injurious to health and can lead to unconsciousness and to death! Never let the engine run in enclosed spaces.
- Danger of burns from hot parts! Do not touch any parts such as engine block, cooling system and exhaust system during operation and for some time after. Let the engine cool down.
- Risk of scalding from hot engine oil! If the cap is opened when the engine is hot, there is a risk of scalding. Let the engine cool down.
- Risk of injury due to rotating parts! Injury of limbs or hair or clothing getting caught up. Switch the engine off and pull out the ignition key.

Attention

- If the engine oil pressure warning symbol **Fig. 98-A** in the multifunction display lights up with the engine running, there is a risk of engine damage! Stop the vehicle in the safe range. Turn the engine off immediately and check the oil level. Have the cause of the inadequate engine oil pressure removed.

Environmental danger

- Ensure safe and environment-conserving disposal of operating and auxiliary materials. Take up escaping or spilled operating materials in suitable containers and dispose of them in an environmentally friendly manner.

5.3.1 Checking the engine oil level

Check the engine oil level daily and refill as required.

1. Place the vehicle on a level surface and hold it with the parking brake. Switch the engine off and pull out the ignition key. Let the engine cool down.



Note

The circulating engine oil requires a few minutes to flow back to the oil sump.

2. Remove the right side panelling, see page 102.
3. Check the engine oil level with the dip stick **Fig. 98-B**.
4. The engine oil level should lie between the MAX and MIN mark of the dip stick and may never drop below the MIN mark.
5. Refill engine oil as required and check the engine oil level once again. Engine oil Titan Cargo 5W-40, API CJ-4



Note

The engine oil level must not be above the MAX mark.

6. Reinsert the dip stick.

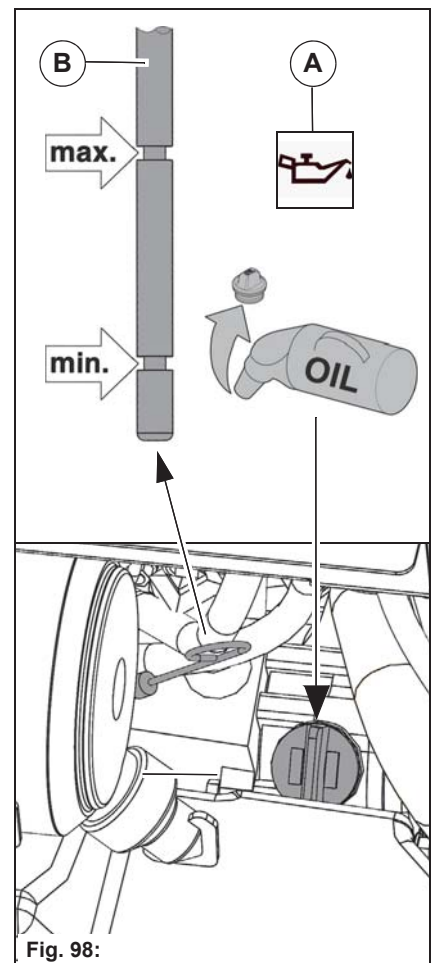

5.4 Fuel system

	<p>Danger</p> <ul style="list-style-type: none">• Risk of fire! Diesel fuel is flammable! Take the utmost care when handling fuel. Never refuel close to naked flames or ignitable sparks. Do not smoke during fuelling. Switch off the engine, pull out the ignition key and engage the parking brake before fuelling.• Danger of burns from hot parts! Do not touch any parts such as engine block, cooling system and exhaust system during operation and for some time after. Let the engine cool down. <p>Environmental danger</p> <ul style="list-style-type: none">• Ensure safe and environment-conserving disposal of operating and auxiliary materials. Take up escaping or spilled operating materials in suitable containers and dispose of them in an environmentally friendly manner.
---	--

5.4.1 Emptying the water trap

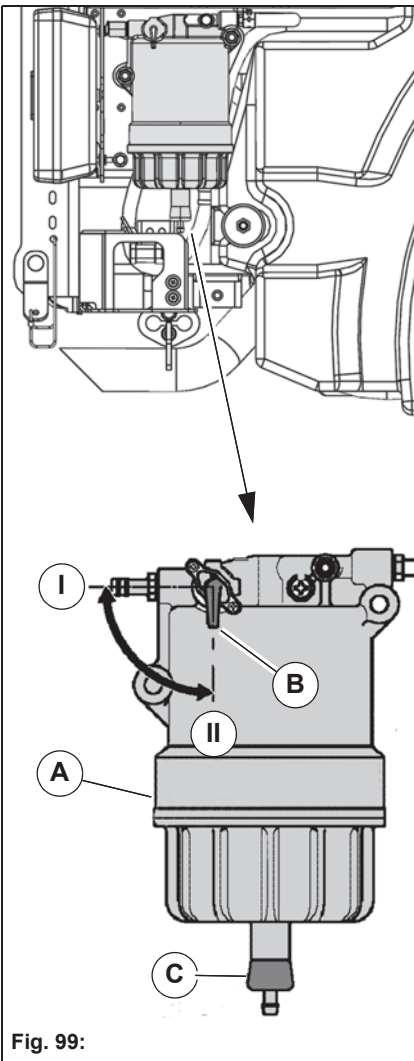

Check the water trap **Fig. 99-A** weekly and drain the condensed water out from the water trap if required.

1. Place the vehicle on a level surface and hold it with the parking brake. Switch the engine off and pull out the ignition key. Let the engine cool down.
2. Remove the right side panelling, see page 102.
3. Place a suitable vessel under the water trap.
4. Close the fuel valve **Fig. 99-B** by turning it into position **Fig. 99-I**.
5. Open the drain valve **Fig. 99-C**. Let the accumulated water drain off.
6. Retighten the drain valve hand-tight.
7. Open the fuel valve again by turning it into position **Fig. 99-II**.

Fig. 99:

5.5 Cooling system



Danger

- Danger of burns from hot parts! Do not touch any parts such as engine block, cooling system and exhaust system during operation and for some time after. Let the engine cool down.
- Risk of scalding from hot coolant! The cooling system is under pressure. If the cooling system cap is opened with a hot engine there is a risk of scalding. Let the engine cool down.
- Risk of injury due to rotating parts! Injury of limbs or hair or clothing getting caught up. Switch the engine off and pull out the ignition key.

Attention

- The cooling fins are very thin and can be damaged easily!
- Small air bubbles can form when the radiator is filled. Therefore the cooling system must be vented at the same time. Have this done by an authorised workshop!

Environmental danger

- Ensure safe and environment-conserving disposal of operating and auxiliary materials. Take up escaping or spilled operating materials in suitable containers and dispose of them in an environmentally friendly manner.

5.5.1 Cleaning the cooling system

Check the grille sieve and the combination radiator located behind it daily and clean as required.

1. Place the vehicle on a level surface and hold it with the parking brake. Switch the engine off and pull out the ignition key. Let the engine cool down.
2. Open the grille sieve **Fig. 100-A** with the catch **Fig. 100-B**.
3. Check the grille sieve and the combination radiator located behind it for contamination and clean as required with compressed air or water jet.

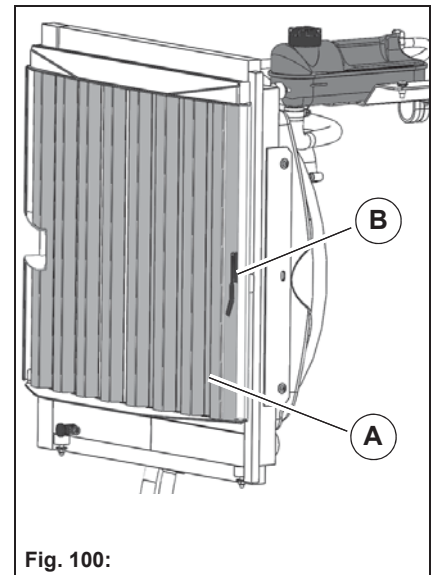

Fig. 100:

5.5.2 Checking the coolant level

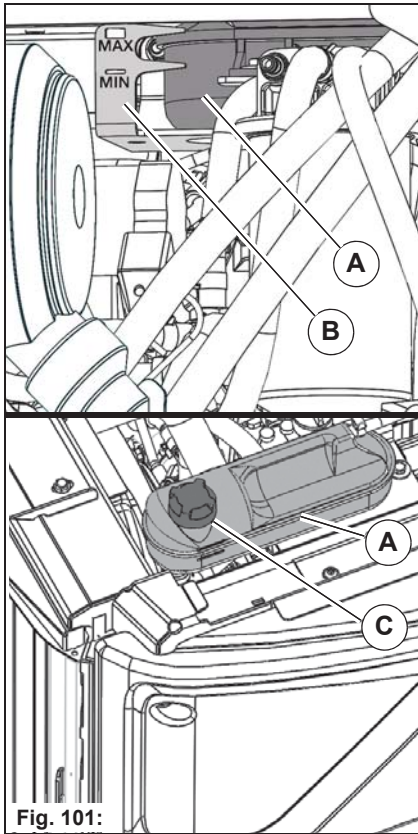

Fig. 101:

Check the coolant level in the expansion tank **Fig. 101-A** daily and refill as required.

1. Place the vehicle on a level surface and hold it with the parking brake. Switch the engine off and pull out the ignition key. Let the engine cool down.
2. Open the right side panelling, see page 102.
3. Check the coolant level.
The coolant level of the expansion tank **Fig. 101-A** must be between the upper and lower mark **Fig. 101-B** when the engine has cooled down.
4. Unscrew the cap **Fig. 101-C** carefully step by step from the expansion tank.
5. Refill coolant:
Coolant: Glaceelf Auto Supra
The coolant additive must be at least 40 % and may be a maximum of 60 %. Never drive without coolant additive!
6. Check the coolant level, refill once again if necessary.
7. Close the cap again.

5.6 Air filter



Danger

- Danger of burns from hot parts! Do not touch any parts such as engine block, cooling system and exhaust system during operation and for some time after. Let the engine cool down.

Attention

- We can assume no liability for cleaned filter inserts. Never let the engine run without a filter insert!
- Only replace the safety cartridge, do not clean it! Never let the engine run without safety cartridge!

Environmental danger

- Ensure safe and environment-conserving disposal of operating and auxiliary materials. Take up escaping or spilled operating materials in suitable containers and dispose of them in an environmentally friendly manner.

5.6.1 Checking the air filter

Check the contamination of the air filter daily. The maintenance indicator **Fig. 102-A** indicates the degree of contamination.

5.6.2 Cyclone separator and dust ejection valve

The air filter has a cyclone separator incorporated in the filter housing. This lengthens considerably the service life of the filter insert. The dust particles separated in the filter housing are ejected from the dust ejection valve **Fig. 102-B**.

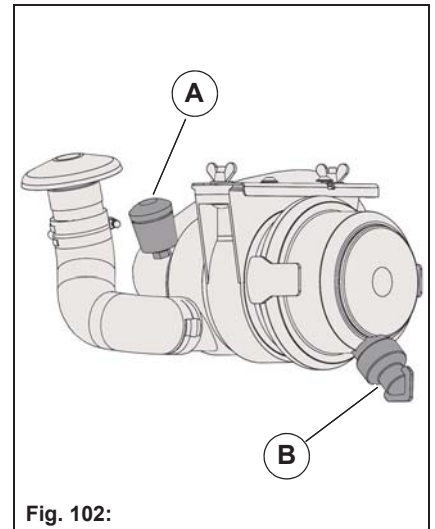

Fig. 102:

5.6.3 Cleaning/changing the air filter

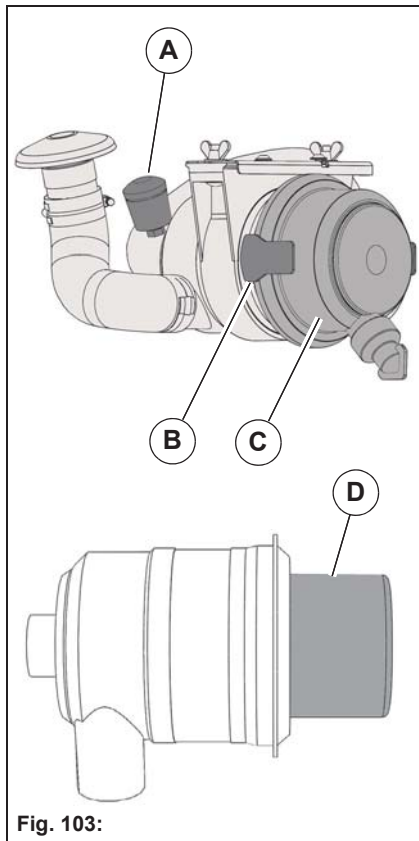

Fig. 103:

Check the filter insert **Fig. 103-D** corresponding to the maintenance indicator **Fig. 103-A** and clean it if required. Change the filter insert at the latest every 500 operating hours.

1. Place the vehicle on a level surface and hold it with the parking brake. Switch the engine off and pull out the ignition key. Let the engine cool down.
2. Open the right side panelling, see page 102.
3. Open the clips **Fig. 103-B** and remove the filter lid **Fig. 103-C**.
4. Remove the filter insert **Fig. 103-D** and clean it from inside to outside carefully with dry compressed air (max. 3 bar) by up and down movements of the compressed air tube.
5. Immediately renew a very dirty or damaged filter insert.
6. Clean the filter housing from the inside.
7. Refit the filter insert.

5.6.4 Changing the safety cartridge

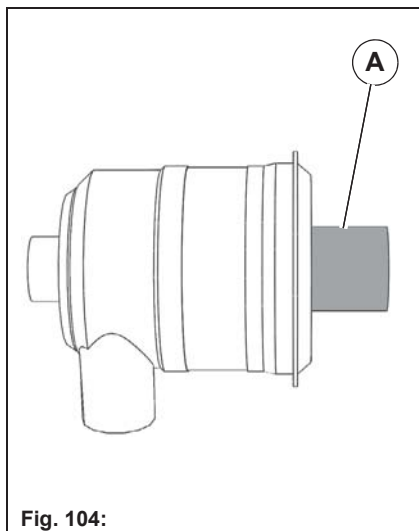

Fig. 104:

Renew the safety cartridge **Fig. 104-A** at the latest every 1000 operating hours when changing the filter insert.

There is a safety cartridge in the centre of the filter insert. The purpose of this safety cartridge is to prevent dirt reaching the suction opening during filter cleaning or filter changing.

1. Place the vehicle on a level surface and hold it with the parking brake. Switch the engine off and pull out the ignition key. Let the engine cool down.
2. Open the right side panelling, see page 102.
3. Open the clips **Fig. 103-B** and remove the filter lid **Fig. 103-C**.
4. Remove the filter insert **Fig. 103-D**.
5. Remove and change the safety cartridge **Fig. 104-A**.

5.7 Hydraulic system

**Danger**

- Risk of injury from hydraulic oil! Hydraulic oil issuing under high pressure can penetrate the skin and cause severe injuries. Therefore, even with the smallest wounds, consult a doctor since otherwise severe infections can arise!
- Danger of burns from hot parts! Do not touch any parts such as engine block, cooling system and exhaust system during operation and for some time after. Let the engine cool down.

Warning

- Do not touch any parts such as engine block and exhaust system during operation and for some time after – risk of burns!
- Work on the hydraulic system of the vehicle may be done only by persons with special knowledge and experience in hydraulics.
- Regularly check all pipes, hoses and screw connections for leaks and external visible damage. Immediately rectify damage and leaks. Oil squirting out can cause injuries and fires. Observe the recommended replacement intervals for hydraulic pipes. Replace hydraulic hose lines every five years from the date of manufacture, even if they do not seem to be damaged!
- Do not change over hydraulic pipes! Fittings and the length and quality of the hose line must comply with the requirements.

Environmental danger

- Ensure safe and environment-conserving disposal of operating and auxiliary materials. Take up escaping or spilled operating materials in suitable containers and dispose of them in an environmentally friendly manner.

5.7.1 Important information for using BIO OIL

	<p>Attention</p> <ul style="list-style-type: none"> • Use only the BIO hydraulic fluids approved by the Hako GmbH, see Operating materials and lubricants. Use of another not recommended products must be agreed with Hako without fail. In addition, a written guarantee declaration must be obtained from the supplier. This guarantee applies for the case that damage to hydraulic units occurs that is demonstrably attributable to the hydraulic fluid. • Use only BIO oil of the same grade for topping up and oil changing. To prevent misunderstanding, a clear indication of the currently used oil grade is or must be affixed to the hydraulic tank in the vicinity of the filler pipe. Mixing two BIO oil grades can impair the properties of one grade. Make sure that when the BIO oil is changed, the remaining residual volume of the original hydraulic fluid in the hydraulic system does not exceed 8 % (manufacturer's data). • Do not top up with mineral oil. The mineral oil content should not exceed 2 % by weight to avoid foaming problems and not to impair the biological degradability of the BIO oil. • The same oil and filter changing intervals apply for operation with BIO oils as for mineral oils, see Operating materials and lubricants. The condensed water in the hydraulic oil tank must be drained off before the cold season. The water content should not exceed 0.1 % by weight. • All information about environmental protection in this operating manual also applies when BIO oils are used. • If additional hydraulic devices are attached and operated, then operate these with the same BIO oil grades, so that mixing in the hydraulic system is avoided. • In subsequent oil changing from mineral to BIO oil, the hydraulic units must be scavenged completely.
---	---

Safety instructions – Hydraulic hose lines

For more information, please see:

- Latest version of DGUV rule 113-020 "Hydraulic hoses and hydraulic fluids - rules for safe use"
- DIN 20066 T5

Identification of hydraulic hose lines

Regardless of the flexible line, each hydraulic hose line is permanently marked with at least the following information on the press sleeve:

- manufacturer's name or identification, e.g. XXX,
- operating pressure (maximum working pressure) of hydraulic hose line, e.g. 330 bar,
- the last two digits of the year of manufacture and the month of manufacture, e.g. 20/01 for January 2020.

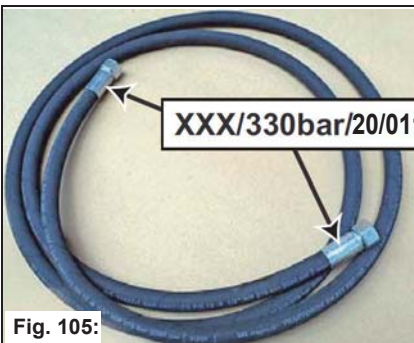

Fig. 105:

5.7.2 Checking the hydraulic oil level

Check the hydraulic oil level weekly at the level indicator **Fig. 106-A** and top up as required. Use only hydraulic oils approved by the manufacturer (HVL P 46) e.g. Mobiloil DTE 10 Excel.

1. Place the vehicle on a level surface and hold it with the parking brake.
Switch the engine off and pull out the ignition key. Let the engine cool down.
2. Open the left side panelling, see page 102.
3. Unscrew the cap **Fig. 106-B** and top up with hydraulic oil.
4. The hydraulic oil level should lie between the MIN and MAX mark.
5. Refit the cap.



Attention

The specification of the grade of hydraulic oil added in the factory can be found on an adhesive plate in the vehicle cab **Fig. 106-C**. Only use the identical hydraulic oil for topping up. Mixing different hydraulic oils is not permitted. This would reduce the efficiency and reliability of your machine. Hydraulic components could be damaged. If all of the hydraulic oil is replaced, the usual procedures must be noted (e.g. flush several times, maximum residual hydraulic oil content: 2 %). Note the name of the new hydraulic oil on the existing adhesive plate with a permanent marker. If the vehicle is used under different climatic conditions than when the initial filling took place (e.g. HVL P 46 for central European conditions), hydraulic oil with a different viscosity class must be used.

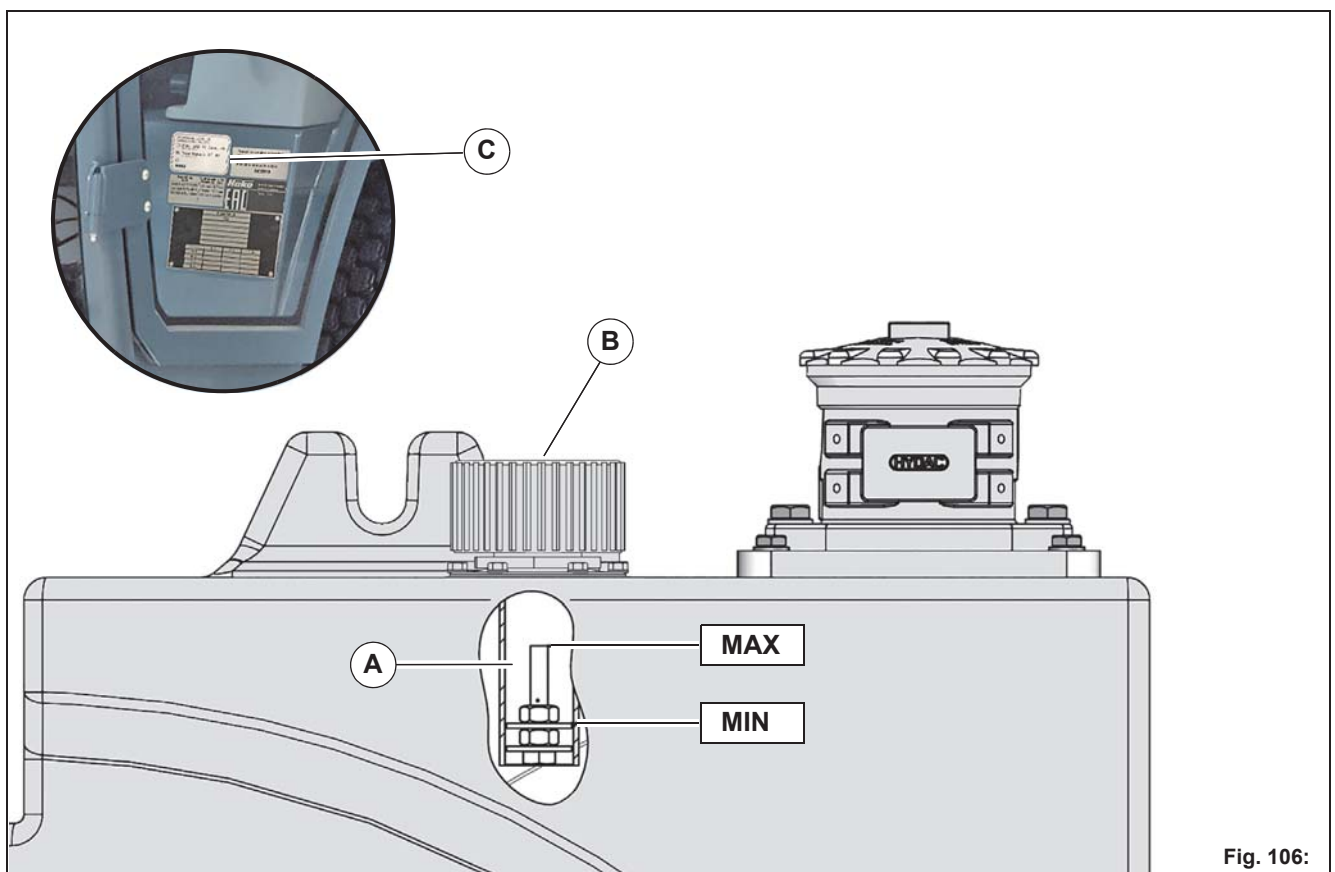

Fig. 106:

5.8 Driver's cab

5.8.1 Changing the cab air filter

Check the cab air filter weekly for contamination, more frequently in dusty work. Remove it as follows:

1. Place the vehicle on a level surface and hold it with the parking brake. Switch the engine off and pull out the ignition key.
2. Loosen the four mounting screws of the protective grille **Fig. 107-A** and remove the protective grille.
3. Remove and clean the cab air filter **Fig. 107-B** and renew it if necessary.

Summer operation

Insert the perforated plate **Fig. 107-C** located behind the cab air filter so that the mark points to the "S".

Winter operation

Insert the perforated plate located behind the cab air filter so that the mark points to the "W".

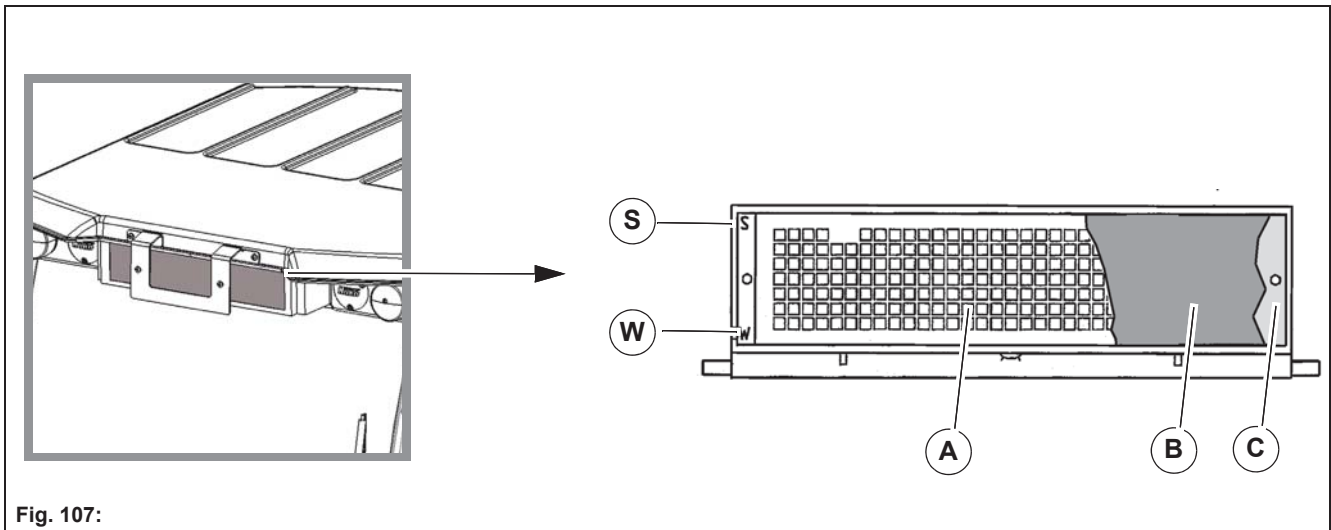

Fig. 107:

5.9 Wheels



Danger

- Risk of accident! Repair work on tyres and rims may be undertaken only by skilled personnel or authorised workshops.

Warning

- When changing wheels, make sure that the jack is applied to the specified jacking point.
- Damaged tyres and/or incorrect tyre pressure reduce the operating safety of the vehicle. There is a risk of an accident with tyres with too low or too high tyre pressure!
- Check the wheel nuts regularly for firm seating. After a tyre change check the wheel nuts after 50 km and tighten them if necessary.

5.9.1 Tyre changing

Dismantling

1. Place the vehicle on a level surface and hold it with the parking brake. Switch the engine off and pull out the ignition key. Let the engine cool down.
2. Fit jack to jacking points on a secure footing:
 - Front wheel left/right: **Fig. 108-A**, see symbol
 - Rear of vehicle left/right: **Fig. 108-B**, see symbol
3. Raise the corresponding axle side and check the vehicle once again for stability.
4. Remove the wheel bolts and remove the wheel.

Mounting

1. Fit the wheel on the centring hub and tighten all wheel bolts slightly.
2. Jack the raised axle side down.
3. Tighten the wheel bolts crosswise with a torque wrench. The permissible tightening torque is: 130 Nm
4. The wheel bolts must be tightened again as described above after approx. 50 operating hours.

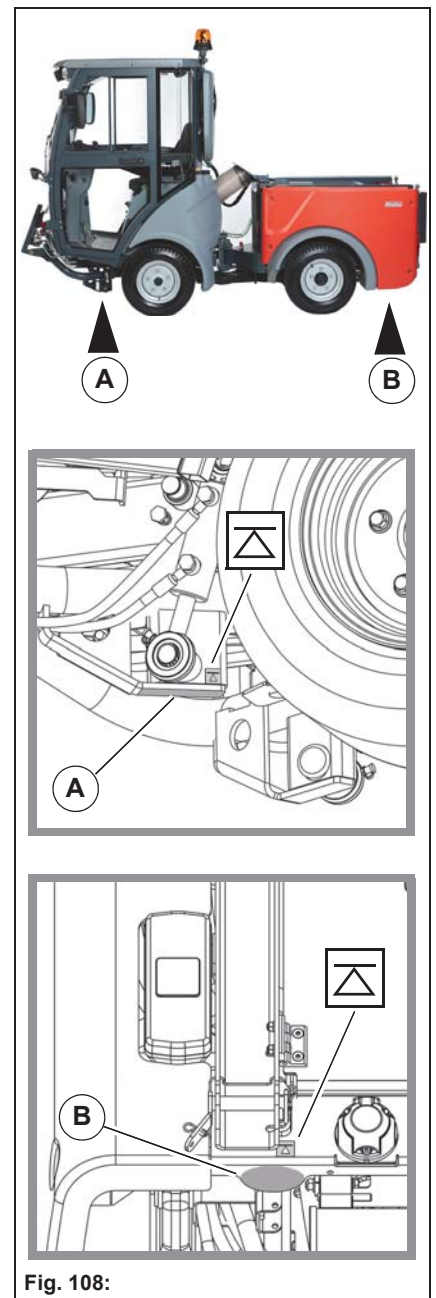

Fig. 108:

5.10 Electrical system

5.10.1 Lamps

Standard lighting	Figure	Electrical value
Dipped headlights	Fig. 109-A	12 V - 55 W
Direction indicator and parking light	Fig. 109-B	12 V - 21 W / 5 W
Direction indicator for brake lights and rear light	Fig. 109-C	12 V - 21 W / 21 W / 10 W
Number plate light	Fig. 109-D	LED
Reversing light (optional)	Fig. 109-E	LED
Interior light	Fig. 109-F	12 V - 5 W
Working light (front work area)	Fig. 109-G	LED

Rotating beacon (optional)	Figure	Electrical value
Standard rotating beacon (optionally)	Fig. 109-H	12 V - 55 W
LED rotating beacon (optionally)	Fig. 109-I	LED

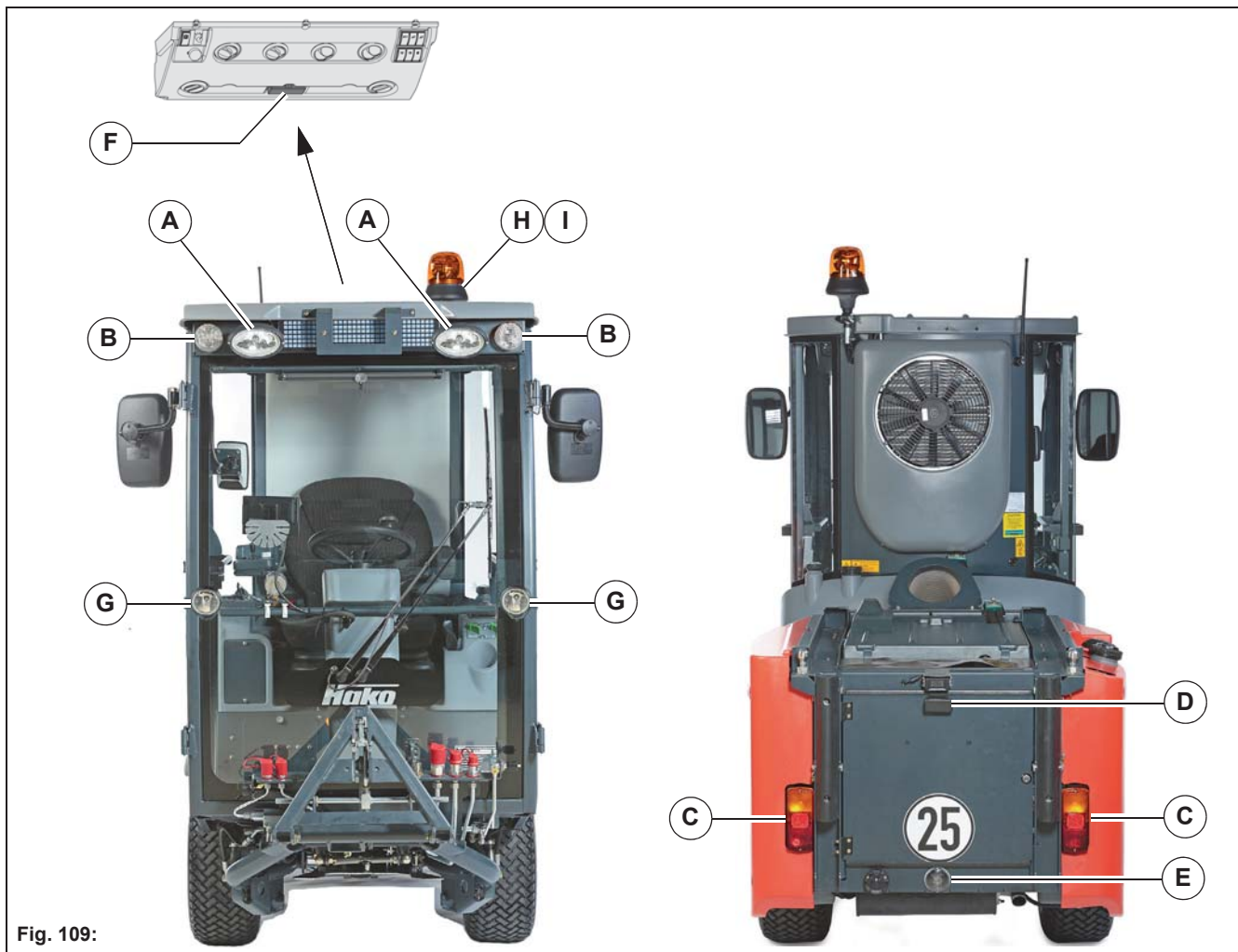

Fig. 109:

LED lighting	Figure	Electrical value
LED lighting (optionally for basic lighting)		
Dipped headlights	Fig. 110-A	LED
Direction indicator and parking light	Fig. 110-B	LED
Direction indicator, brake light, rear light, reversing light and rear fog light	Fig. 110-C	LED
Interior lighting	Fig. 110-D	LED

Working light (optional)	Figure	Electrical value
Working light (rear cab)	Fig. 110-E	LED
Working light (top cab)	Fig. 110-F	LED

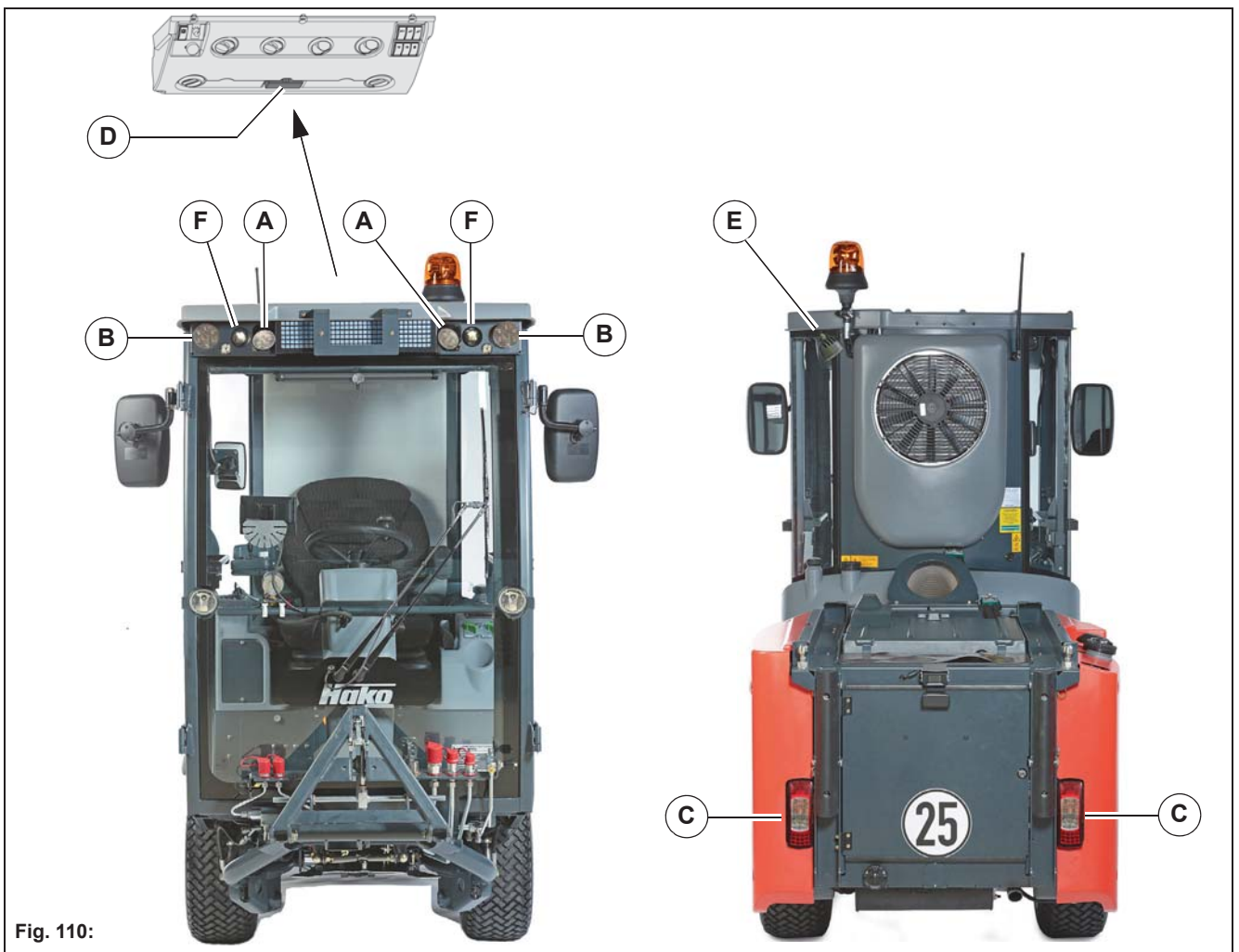

Fig. 110:

5.10.2 Fuses and relays

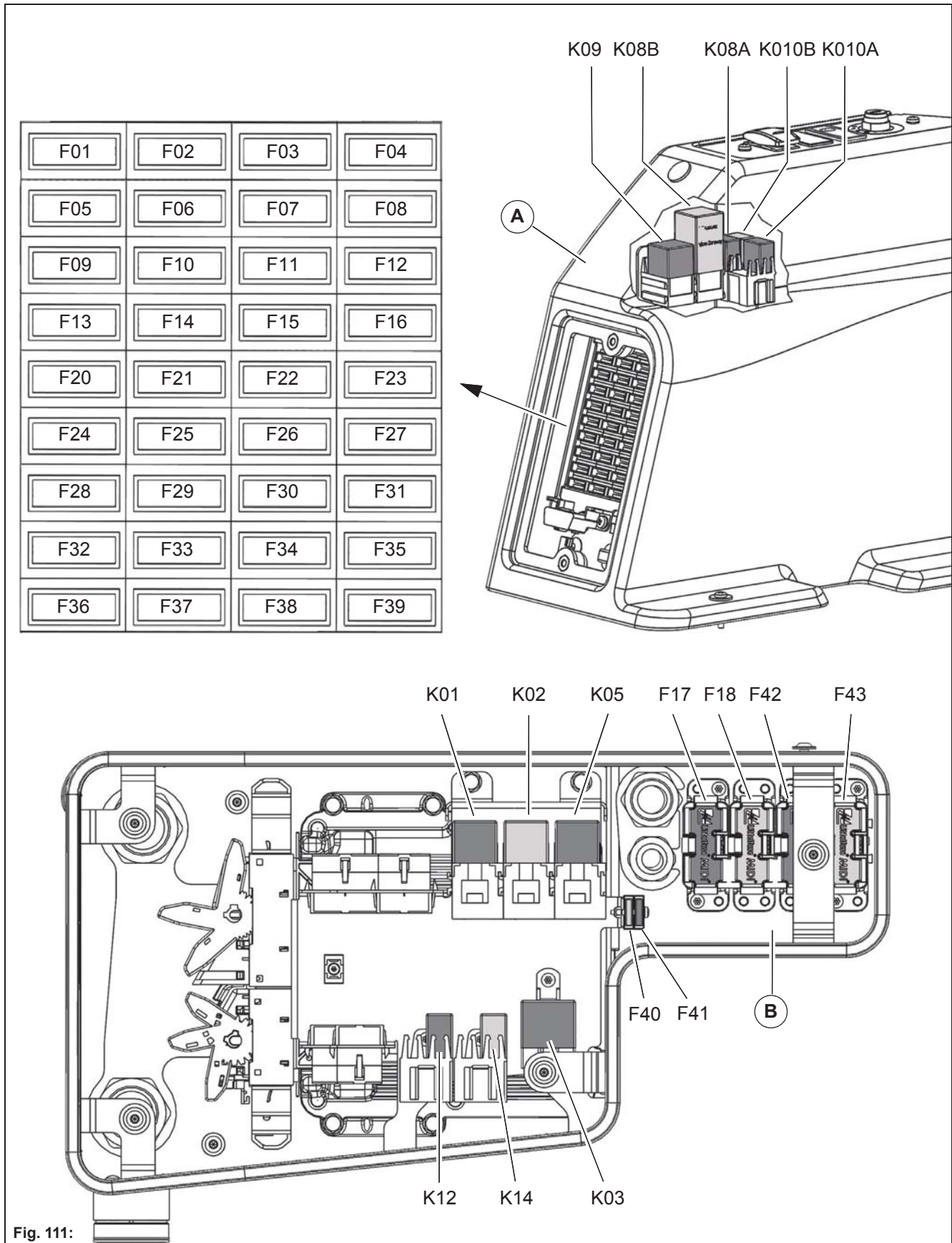

Fig. 111:

No.:	Value	Function
		Fuses – control panel on the right Fig. 111-A:
F01	20 A	Air conditioning system and mirror heating
F02	10 A	Relief of starting process
F03		Not used
F04	10 A	Radio
F05	5 A	Hydraulic control unit
F06	15 A	Control unit for driving, fuel pump
F07	15 A	Fresh water pump
F08	15 A	Control unit for working hydraulics, rear socket
F09	10 A	Windscreen washer unit and hydraulic control unit
F10	15 A	Heating and air conditioning system
F11	15 A	Working light, front
F12	15 A	Main front headlight and rear fog light
F13	10 A	Rotating beacon and interior light
F14	15 A	Blinker / Warning light
F15	7.5 A	Rear light (terminal 58L) and parking light (terminal 57L)
F16	7.5 A	Rear light (terminal 58R) and parking light (terminal 57R)
F20	7.5 A	Starter
F21	10 A	Hydraulic control unit and horn
F22	5 A	Hydraulic control unit and multifunction display
F23	15 A	Pre-fuse (F15, F16 and F35)
F24	5 A	USB socket
F25	10 A	Rear cab working light and brake light
F26	15 A	Radio
F27	15 A	Steering column socket
F28	10 A	Driver's seat
F29	5 A	Fleet-Recorder, 12-pin socket (X67)
F30		Not used
F31	5 A	Fleet-Recorder, 12-pin socket (X67)
F32		Not used
F33		Not used
F34	10 A	Drive pump control unit
F35		Not used
F36	5 A	Spare fuse
F37	7.5 A	Spare fuse
F38	10 A	Spare fuse
F39	15 A	Spare fuse

Relays – control panel on the right Fig. 111-A:		
K01		Starter release
K02		Preheat
K03		EGR valve
K04		
K05		Supply terminal 75
K11A		Windscreen washer pump
Electrical box fuses Fig. 111-B:		
F17	50 A	Main fuse
F18	50 A	Main fuse
F40	20 A	Engine control unit ECU
F41	20 A	EGR valve
F42	60 A	Starter
F43	80 A	Drive pump control unit
Electrical box relays Fig. 111-B:		
K08A		Windscreen wiper
K08B		Rear fog light
K09		Air conditioning system
K10A		Relief of terminal 15
K10B		Voltage and proportional valves
K12		Start release
K14		Brake light

5.10.3 Battery



Danger

- Danger of explosion due to smoking, fire or open light! Especially when being charged, but also in the normal use of batteries, batteries emit explosive gases! Avoid smoking, fire, sparks or open light in the vicinity of batteries!
- Danger of explosion due to sparks! Never place tools or other electrically conductive objects on the battery! Sparks that can ignite escaping gases arise if the poles are short-circuited. Always observe the correct order when connecting and disconnecting the battery!
 - Disconnecting the battery: First the minus pole and then the plus pole!
 - Connecting the battery: First the plus pole and then the minus pole!
- Danger of explosion due to frozen battery or too low acid level! With a frozen battery or if the acid level is too low, do not attempt to start with a jumper cable, the battery can burst or explode.
- Danger of burns due to battery acid! The special safety and accident prevention regulations must be complied with when handling the battery. Batteries contain sulphuric acid.

Battery isolating switch (optional)

The battery isolating switch is located on the right-hand side of the vehicle above the battery. If the vehicle is parked for a longer period of time, the battery may self-discharge. For this case:

1. Switch off the vehicle with the ignition switch.
2. Open the right side panelling, see page 102.
3. Turn the battery isolating switch **Fig. 112-A**. The battery is isolated from the vehicle electrical system. Switch the vehicle electrical system back on by rotating clockwise.

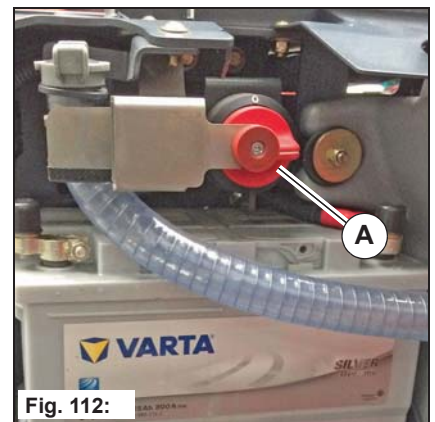

Fig. 112:

Removing the battery

1. Place the vehicle on a level surface and hold it with the parking brake. Switch the engine off and pull out the ignition key. Let the engine cool down.
2. Open the right side panelling, see page 102.
3. If present, switch the battery isolating switch off and remove the key.
4. Loosen the battery holder **Fig. 113-A**.
5. Disconnecting the battery: First the minus pole and then the plus pole!
6. Remove the battery. Clean and grease the battery poles.
7. Recharge the battery or replace it by a new battery of the same strength.
8. Connecting the battery: First the plus pole and then the minus pole.



Fig. 113:



Fig. 114:

Starting with jumper cables

1. Place the vehicle on a level surface and hold it with the parking brake. Switch the engine off and pull out the ignition key. Let the engine cool down.
2. Switch engine and electrical consumers of both vehicles off.
3. Open the right side panelling, see page 102.
4. Connect the plus cable (red) with one end to the plus pole (+) of the empty battery and with the other end to the plus pole (+) of the assisting vehicle.
5. Connect the minus cable (black) to the minus pole (-) of the supporting vehicle and to the minus pole (-) of the Citymaster 650.
6. Start the engine of the assisting vehicle.
7. Start the Citymaster 650.
8. When removing the jumper cable, first remove the minus poles (-) and then the plus poles (+).

5.11 Lubrication plan



Note

The lubricating nipple has a yellow protection cap. Clean the area around the grease nipple before lubricating!

Item	Name
A	Door hinges left, right, above and below (4x)
B	Front lifting cylinder left, right, above and below (4x)
C	Articulated joint (4x)
D	Steering cylinder (2x)
E	Front lift left/right (2x)
F	Single-point lubrication system (option) (1x) – on the front wagon at the bottom right.

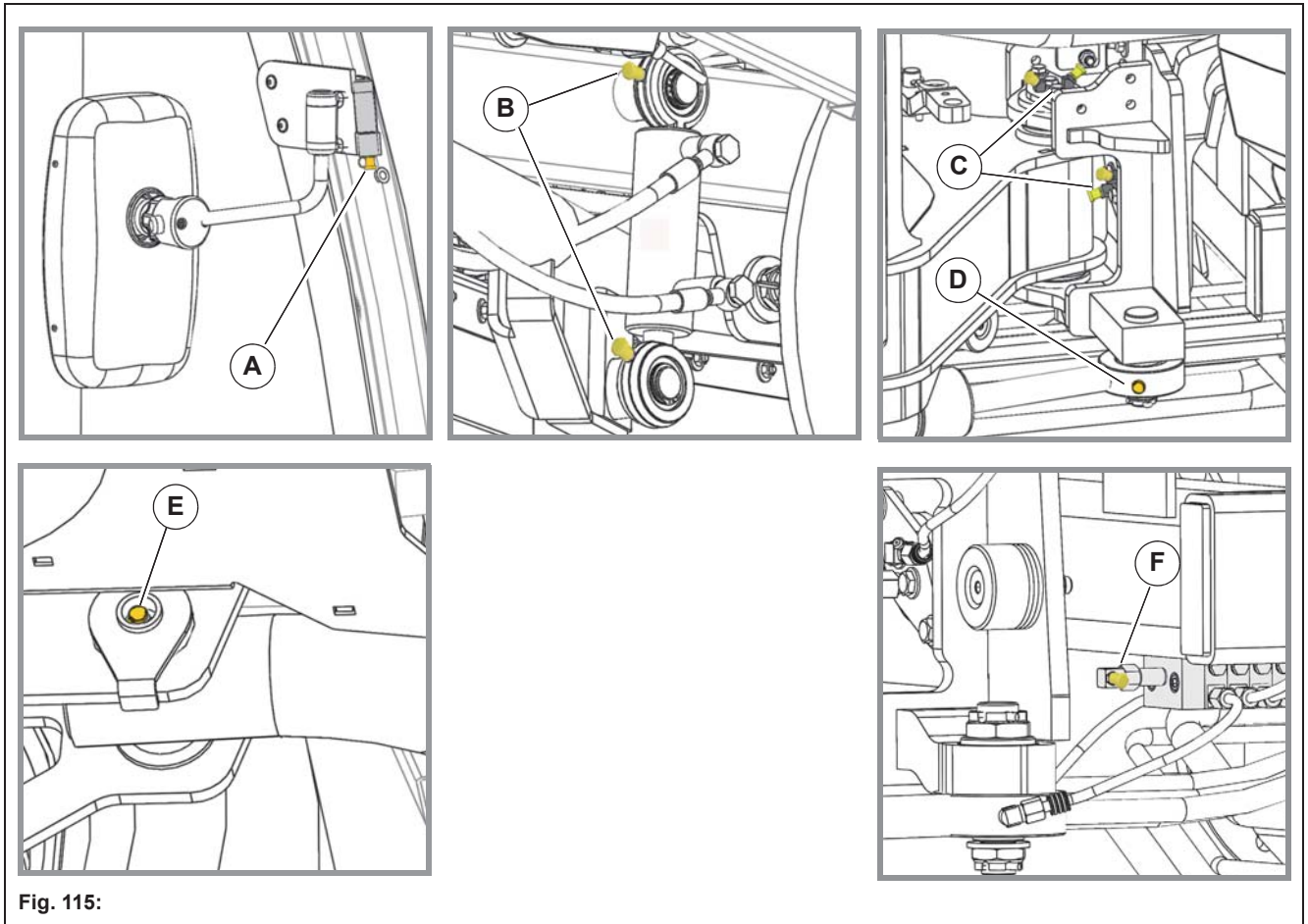



Fig. 115:

5.12 Cleaning the vehicle

	<p>Danger</p> <ul style="list-style-type: none">• Danger of burns from hot parts! Do not touch any parts such as engine block, cooling system and exhaust system during operation and for some time after. Let the engine cool down. <p>Attention</p> <ul style="list-style-type: none">• Use only dedicated washing places for cleaning the vehicle.• When cleaning the engine with a water or steam jet cleaner, do not expose electrical plug connections and sensors, such as oil pressure switch, to a direct jet. Otherwise penetrating moisture can lead to corrosion and to failure of the measuring function!• Never clean the driver's cab inside with a high-pressure cleaner, steam jet cleaner or with a strong water jet. Water under high pressure can:<ul style="list-style-type: none">• Penetrate the vehicle electrical system and cause a short circuit.• Damage seals and make operating elements defective!
---	--

5.12.1 General notes

A distinction is made between 3 areas in vehicle cleaning:

- Driver's cab inside
- Complete vehicle outside
- Engine space

Here the wrong choice of cleaning equipment and agents can impair the operating safety of the vehicle and also endanger the health of the cleaning personnel. Therefore the following instructions should be followed without fail:

When using washing solutions

- Ensure sufficient room ventilation
- Wear suitable protective clothing
- Do not use any combustible liquids such as petrol or diesel fuel

When using compressed air

- Work carefully
- Wear eye protection and protective clothing
- Do not direct compressed air onto the skin or towards other persons
- Do not use compressed air for cleaning clothes

When using a high-pressure cleaner or steam jet cleaner

- Maintain a minimum distance of at least 30 cm!
- Max. pressure 120 bar at max. 80 °C
- Cover electrical parts and insulating mats and do not expose them to a direct jet.
- Cover these parts and do not expose them to a direct jet: vent grilles on the rear wall of the driver's cab, venting filter of the hydraulic oil tank and lid of fuel and hydraulic oil tank etc.
- Protect the following components against moisture:
 - Electrical parts, such as three-phase generator, sensors, electrical plug connections, engine control unit, etc.
 - Control devices and seals
 - Air suction filter etc.

When using volatile and easily flammable anti-rust agents and sprays:

- Ensure sufficient room ventilation
- Use no naked fire or light!
- Do not smoke!

Wash your vehicle at regular intervals with water and a mild detergent. How frequently the vehicle has to be washed depends on the following factors:

- Area of use of the vehicle
- Driving on roads spread with salt
- Parking under trees with resinous excretions

Observe the following when washing:

- Do not use any coarse brushes or dirty cloths to prevent scratching and dulling the paintwork.
- Do not wash the vehicle if it has been exposed to sunshine for a long time, the paintwork could lose its gloss by this.

Clean outer plastic parts like the vehicle. If dirt cannot be removed in this way, we recommend special plastic cleaners. You can also use these inside the vehicle for plastic parts.

Do not use any paint cleaners or products containing solvents, methanol or hydrocarbons.

Use special glass cleaners and clean cloths to avoid scratches and dulling.

We recommend the following aids for cleaning the driver's cab:

- Vacuum cleaner
- Damp cloths
- Soft brush
- Bucket of water

Remove dust on seats and other fabric surfaces with a soft brush or vacuum cleaner. More thorough cleaning can be achieved with special upholstery detergent. Observe the directions for use and danger notes of the manufacturer!

Solvents on a chlorine basis may not be used.

Care of the outside body

Cleaning plastic parts

Cleaning glass areas

Driver's cab inside

Cleaning fabric surfaces

6 Attachments and Options

Safety instructions for attachments

	<p>Danger</p> <ul style="list-style-type: none">• Danger to life in the danger area of the vehicle! Special caution is required under the raised tipper, in the area of the front and rear attachment and in the area of the trailer.• Risk of injury! Put the attachment into service only if all protective devices are attached and in protection position.• Risk of injury! Make sure that the attachments are suitable for the set oil volume. An oil volume set too high can lead to injuries due to a defect of the attachment!• Risk of injury! High-pressure hoses, fittings and couplings are important for equipment safety. Use only high-pressure hoses, fittings and couplings recommended by the manufacturer.• Risk of accident! When connecting attachments to the hydraulic system, ensure that the hydraulic hoses are connected correctly. Swapping the connections can lead to reverse functioning of the attachment, e.g. movement to the right rather than the left.• Risk of accident! Front attachments not correctly fastened to the front tool carrier can drop down while driving. Always secure the front attachment with the locking devices.• Risk of accident! You must consult Hako before attaching other attachments not approved by Hako! Check in the individual case that the relevant axial loads and total weights are complied with.• Risk of accident! Handling, steering and braking as well as stability are influenced by attachments, trailers and the vehicle payload (e.g. full dirt hopper). For this reason, pay attention to adequate steering and braking capability as well as stability.• Risk of accident! In Germany, if attachments extend beyond the outer lighting equipment of the vehicle or if the maximum distances of the outer lighting equipment specified according to StVZO are exceeded, the lighting equipment of the vehicle must be repeated (see Merkblatt StVZO § 30, explanations 11 and 12).
---	---

Safety instructions for ballast

	<p>Danger</p> <ul style="list-style-type: none">• Risk of accident! When attaching other devices not approved by Hako, check in the individual case whether the relevant axle loads and total weights are complied with!• Risk of accident! The front axle of the working machine must always be loaded with at least 21 % of the empty weight and the rear axle with at least 42 % of the empty weight of the working machine.• Risk of accident! The front and rear attachments must not lead to exceeding the permissible total weight, the permissible axle load and the tyre load capacity of the working machine! <p>Attention</p> <ul style="list-style-type: none">• Make sure before purchasing the attachment that these requirements are fulfilled by weighing the working machine attachment combination!
---	---

6.1 Vacuum sweeping system



Fig. 116:

Item	Designation	Type
83	Sweeping unit rotating brush	
84	Sweeping unit suction mouth	
85	Dirt hopper	

6.1.1 Labels on the unit

Safety foil

The safety foils (red/white) **Fig. 116-A** are located on the cover of the sweeping unit and at the back of the dirt hopper.

Hako logo

The Hako logo **Fig. 116-B** is located on the cover of the sweeping unit.

Type plate

A type plate **Fig. 116-C** is located on the sweeping unit, on the dirt hopper, on the trolley and on the supports.

Label PM10

The fine dust certificate label PM10 **Fig. 116-D** is located on the dirt hopper.

6.1.2 Vacuum sweeping system safety instructions



Danger

- Danger to life in the danger area of the vehicle! Special caution is required under the raised tipper and in the area of the sweeping unit.
- Danger of tilting over when driving uphill or downhill and transversely to a slope! Avoid sudden turns when driving uphill or downhill or across slopes. There is a risk of tilting over in an inclined position! The vehicle speed must always be adapted to the surrounding conditions and the load condition.
- Danger of tilting due to wrong steering! Note that the steering behaviour of an articulated steered vehicle differs essentially from that of a car. Sudden steering movements at high speed or too high speeds when turning can cause the vehicle to tilt over.
- Risk of injury! Frequently check the filling level of the dirt hopper. Switch the suction fan off for this! The lid and the side doors of the dirt hopper must not be opened when the suction fan is running.
- Risk of accident! Make transport journeys only with the sweeping unit raised and secured in the transport position.
- Risk of accident! Make transport journeys only with a completely lowered dirt hopper!
- Risk of accident! The stability of the vehicle is influenced by a filled dirt hopper. Handling of the vehicle must be adapted accordingly.
- Risk of accident! Do not exceed the permissible total weight of the vehicle!
- Risk of accident! When the dirt hopper is emptied, the Citymaster 650 must be on a sufficiently load bearing, horizontal surface. Driving with the dirt hopper tilted is not permitted.

Warning

- When removing blockages in the suction hose or attaching the hand suction hose (optional), switch off the engine and wait for the suction fan to come to a standstill.
- The vacuum sweeping system may be operated only in connection with the Citymaster 650. The safety regulations for the Citymaster 650 must be complied with absolutely.

Caution

- The labels attached to the vehicle provide important information for safe operation. Renew labels that are no longer legible or present.
- Spare parts must be original spare parts to guarantee safety.

6.1.3 Mounting

Mounting the suction mouth

1. Place the vehicle on a level surface and hold it with the parking brake.
2. Position the suction mouth **Fig. 117-84** by hand or with the auxiliary tool **Fig. 117-A** centrally under the holding plate **Fig. 117-B**. If required, fix the front tool carrier with the chain **Fig. 117-H** in the upper position. Release the fixation after mounting!
3. Push the joystick **Fig. 117-70** forwards. The holding plate is lowered onto the suction mouth.
4. Shift the suction mouth centrally under the holding plate until the stops **Fig. 117-C** come up to the points **Fig. 117-D**.
5. With the lever **Fig. 117-E** lock and secure the suction mouth on the counter bearing **Fig. 117-F** of the holding plate, see sketch **Fig. 117-G**.

Dismantling is in the reverse order.



Note

If circulating water is in the dirt hopper, the circulating water must be shut off using the ball cock!
Bring the ball cock **Fig. 117-10** into position **II**.

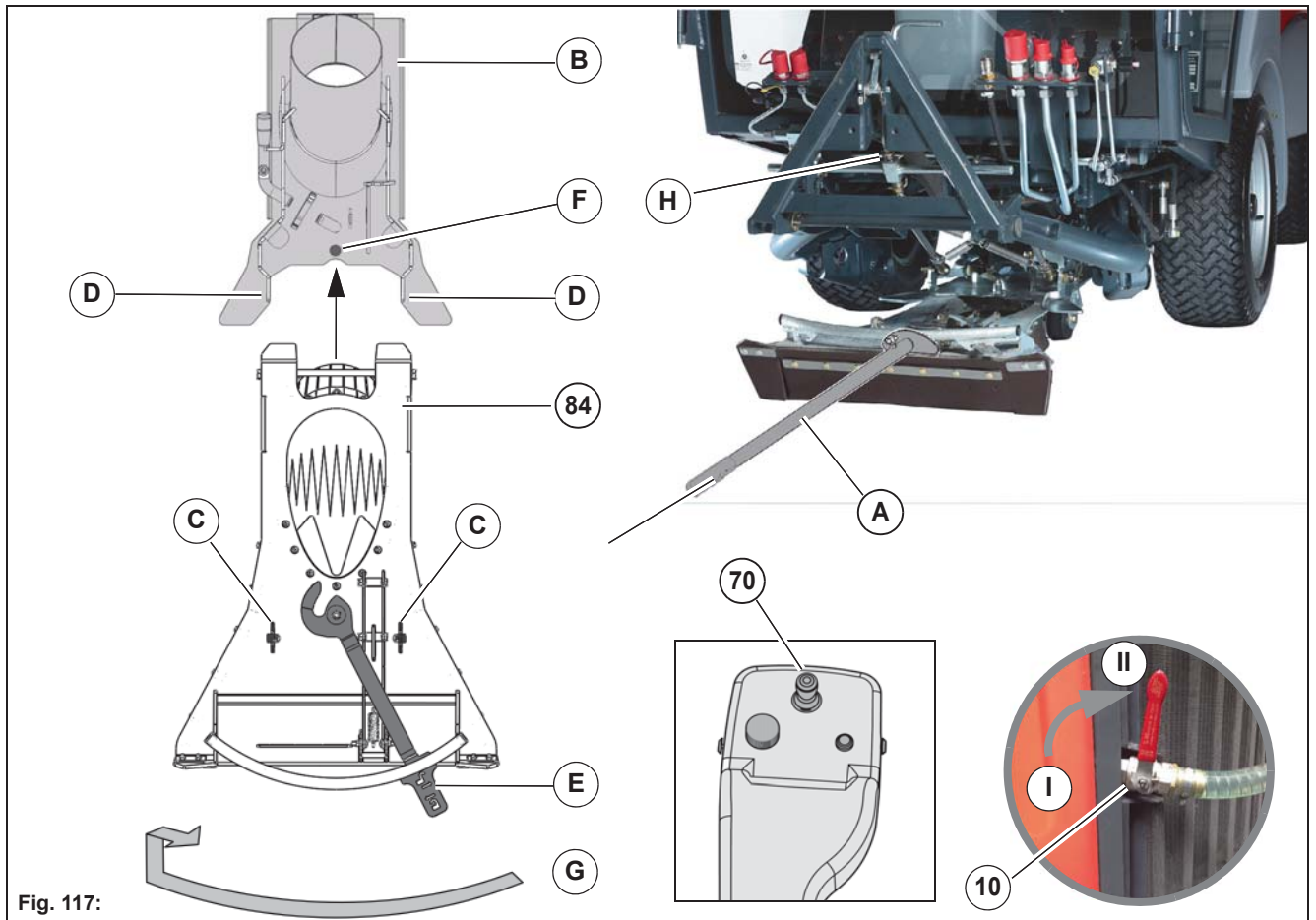

Fig. 117:

Mounting the sweeping unit

1. Place the vehicle on a level surface and hold it with the parking brake.
2. Unlock the locking hook **Fig. 118-A** and locking rod **Fig. 118-B** on the front tool carrier **Fig. 118-12**. Close the valve **Fig. 118-J** for raising the suction mouth and lower the front tool carrier.
3. With an adjustable upper link (optional), set the standard length, see page 73.
4. With the trolley **Fig. 118-96** align the sweeping unit **Fig. 118-83** centrally and in alignment with the front tool carrier.
5. Raise the front tool carrier with the joystick **Fig. 118-70** and attach the sweeping unit.
6. Lock the sweeping unit with the locking hook and locking rod. Check the backlash on the locking hook, see **Fig. 118-L**, adjust if necessary with elongated holes.
7. Open the valve **Fig. 118-J** for raising the suction mouth.
8. Push down the upper part **Fig. 118-K** of the trolley and pull it out from the sweeping unit.

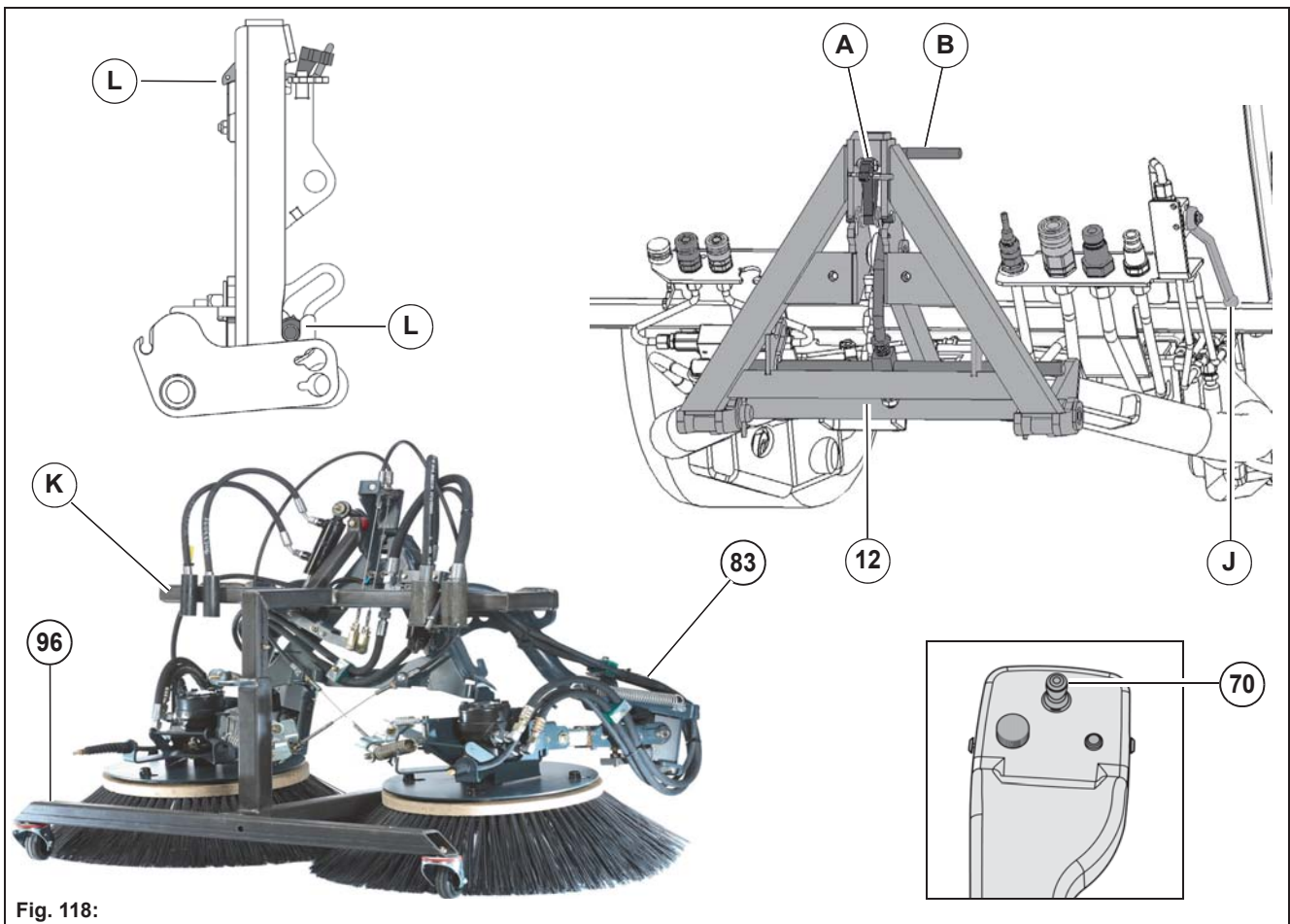

Fig. 118:

Continued – Assembling the sweeping unit

9. Make the connections.

- Swivelling sweeping unit – supply/return = **Fig. 119-D/E**
- 19-pin coding plug = **Fig. 119-F**
- Fresh water connection for the spray nozzles = **Fig. 119-G**
- Sweeping unit hydraulic motors – supply/return = **Fig. 119-I/H**

10. Hook the chain **Fig. 119-M**.

Dismantling is in the reverse order.

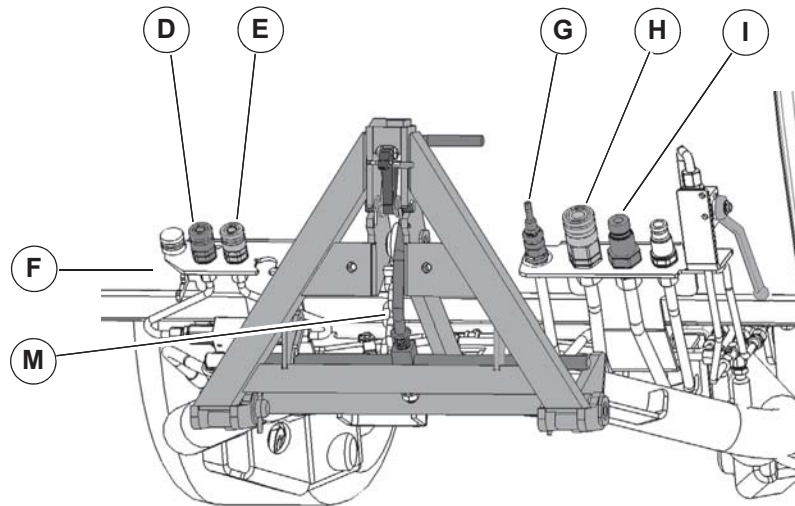

Fig. 119:

Mounting the dirt hopper.

1. Place the vehicle on a level surface and hold it with the parking brake.
2. Unlock the lever **Fig. 120-A** of the trolley **Fig. 120-97** and swing it into the upper position.
3. Hold the lever **Fig. 120-A** in the upper position with one hand. With your other hand plug the mounting bolt **Fig. 120-B** on the Citymaster 650.



Danger

Risk of injury! The lever **Fig. 120-A** can swing over.

4. Unlock the sledge **Fig. 120-C** with the lever and push it into the rear position.
5. Open the lock **Fig. 120-D** of the lid **Fig. 120-E** and swing the lid downwards.

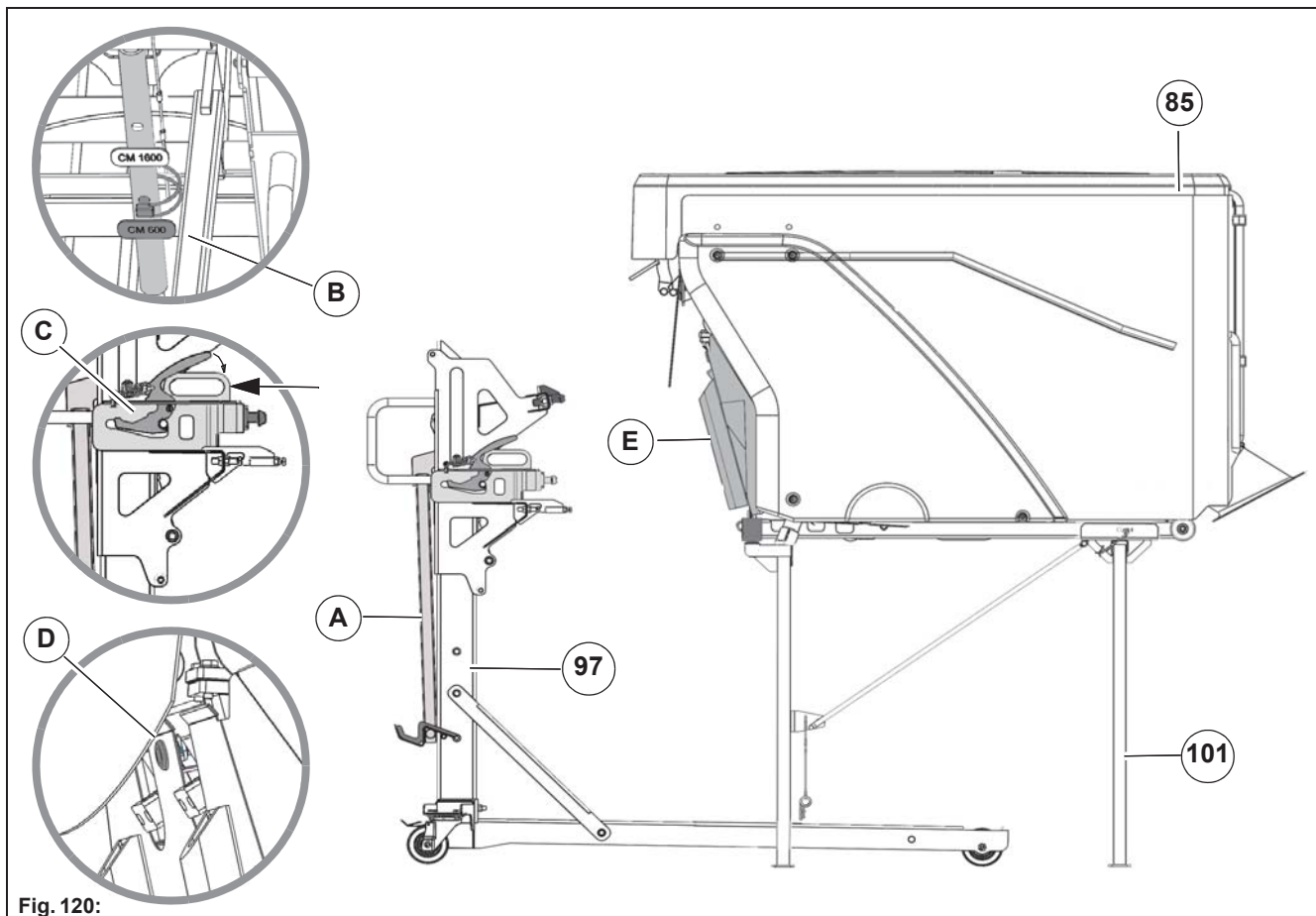

Fig. 120:

Continued – Mounting the dirt hopper



Danger

Risk of injury due to tilting over! Make sure that the cross strut **Fig. 121-G** has been inserted when transporting the dirt hopper on the supports **Fig. 121-101**. Secure the supports with bolts and splints.

6. Push the trolley with the positioning aid **Fig. 121-B** against the fixed bearings **Fig. 121-D** of the dirt hopper. The screw **Fig. 121-C** must be adjusted to 26 mm!
7. Carefully lower the lever **Fig. 121-A** of the trolley and make sure that the upper locking pins **Fig. 121-E** sit in the holders of the dirt hopper **Fig. 121-F**. Lock the lever **Fig. 121-A**.
8. Remove the supports **Fig. 121-101**. To do this, pull out the split pins and the bolts.



Note

Protect the seal of the suction nozzle **Fig. 121-H** with a cover plate.

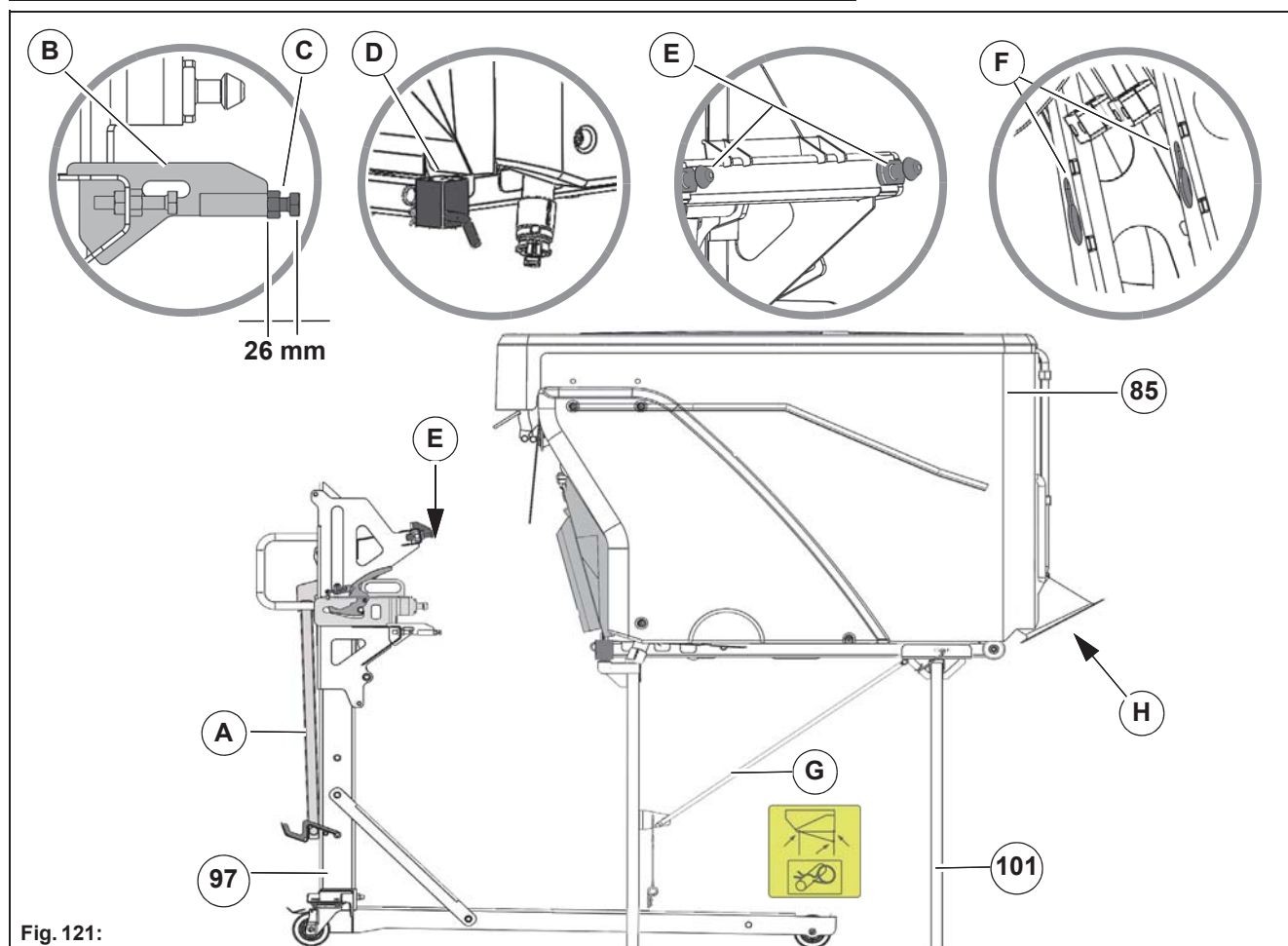

Fig. 121:

Continued – Mounting the dirt hopper

9. Align the dirt hopper to the rear wagon. Procedure:

- Position the dirt hopper over the rear wagon and check the gap size **Fig. 122-X** with 5-10 mm. If necessary, correct with the screw **Fig. 122-A**.
- Push the rollers of the dirt hopper up into the pockets **Fig. 122-B**.
- The fixed bearings **Fig. 122-C** of the dirt hopper and the holders **Fig. 122-D** of the rear wagon must be in alignment.

10. Unlock the lever **Fig. 122-E** of the trolley **Fig. 122-97** and swing it into the upper position. Let the dirt hopper down slowly! Withdraw the trolley and close the lid.

11. Secure the dirt hopper with bolts and splints.

12. Make the connections.

- Lift system hydraulic cylinder – supply/return = **Fig. 122-F**
- Suction fan hydraulic motor – supply/return = **Fig. 122-G**
- Circulating water = **Fig. 122-H**

Dismantling is in the reverse order.

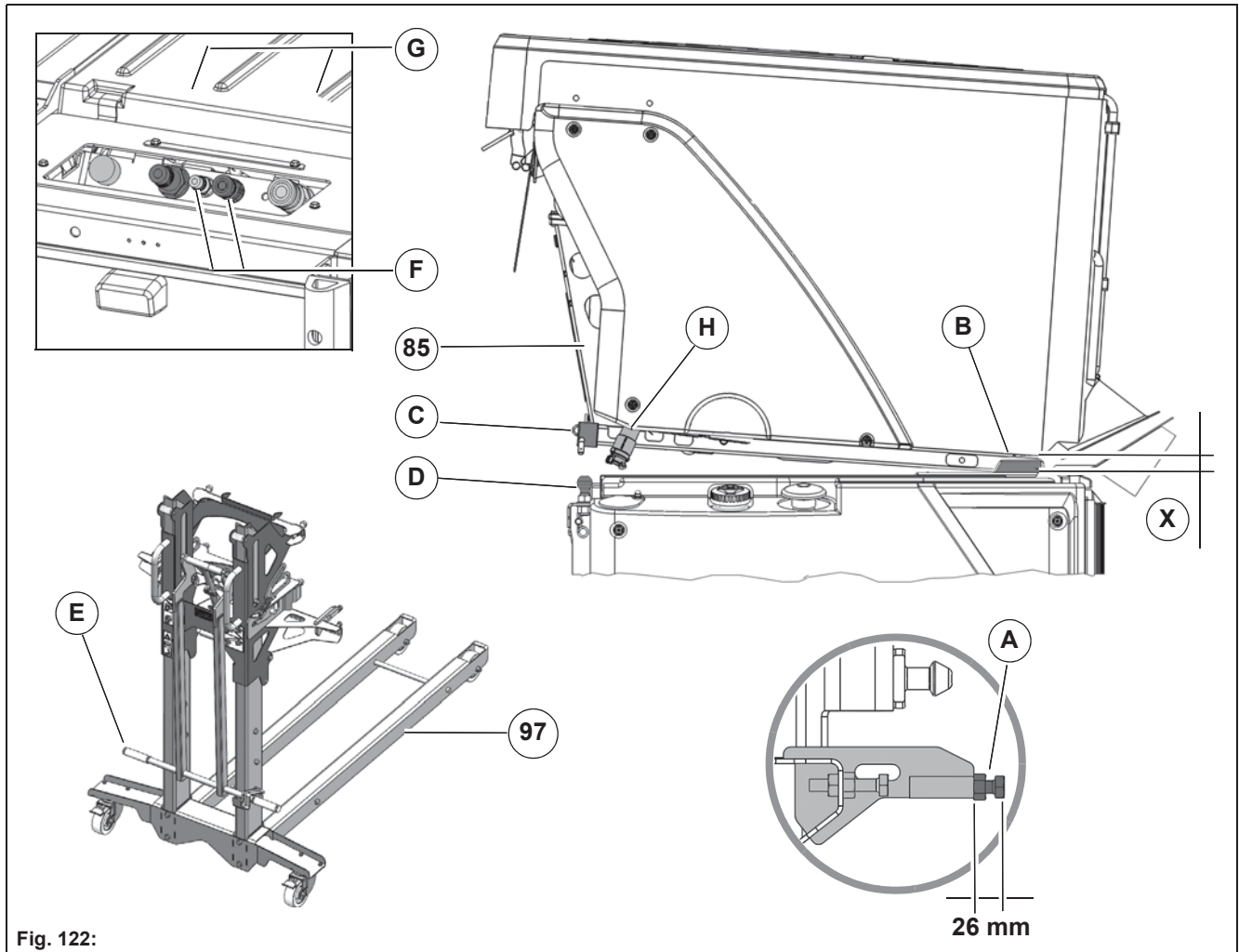

Fig. 122:

6.1.4 Operation

Check-list – Before start-up of the vacuum sweeping system

No.	Description	Reference
1	All items from the check-list – Check before starting the vehicle	Page 80
2	Filling fresh water	Page 133
3	Filling circulating water	Page 133
4	Checking the suction mouth lift system	Page 134
5	Checking the front tool carrier	Page 134
6	Checking the ball cock circulating water	Page 136
7	Checking the transport protection device	Page 134
8	Checking the sweeping level	Page 150
9	Checking the rotating brush pressure	Page 150
10	Checking the suction mouth sealing strips	Page 151
11	Checking the suction duct seal	Page 152
12	Checking lubrication points	Page 152

Filling fresh water

Open the cap **Fig. 123-A** and fill the fresh water tank **Fig. 123-8** until the level indicator **Fig. 123-B** shows maximum.

Hydrant kit (optional)

Filling the fresh water tank from the public water mains with the D hose connection is possible with the hydrant kit (optional). The hydrant kit is mounted above the filling cap and contains a C hose connection, a D hose connection, an installation key and a free-fall section.

	<p>Note Water may be taken from the mains of public water connections only through the "D-hose connection"!</p>
---	--

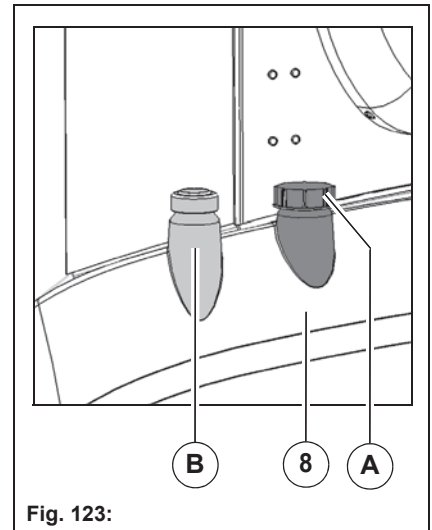

Filling circulating water

Open the lock of the dirt hopper. Fill the dirt hopper using a water hose. Filling volume for circulating water approx. 150 litres. Fill the dirt hopper up to the red mark **Fig. 124-A** at the lower mounting screw of the lateral sieve in the dirt hopper. After filling, check the function of the supply to the suction mouth.

	<p>Note In wet weather fill the dirt hopper only with approx. 100 litres of water. The vehicle sucks the remaining water off from the road when sweeping.</p>
---	--

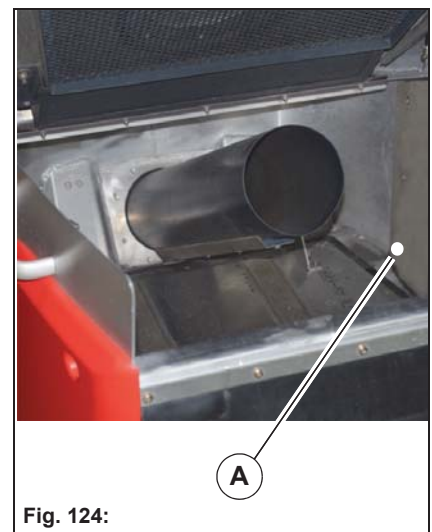

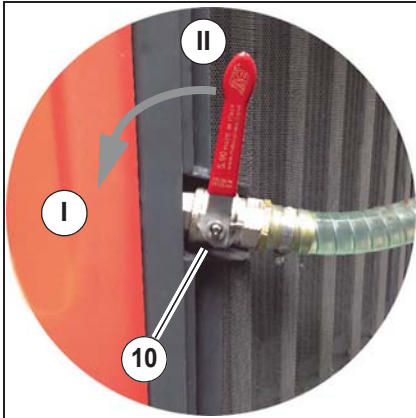

Fig. 125:

Checking the ball cock circulating water

The circulating water is closed off only with the ball cock **Fig. 125-10** for maintenance purposes. In normal operation the ball cock must be opened!

- Circulating water supply opened: Ball cock in position **Fig. 125-I**
- Circulating water supply closed: Ball cock in position **Fig. 125-II**



Note

Close off the circulating water supply only if there is circulating water in the dirt hopper and the suction mouth should be mounted or dismounted.

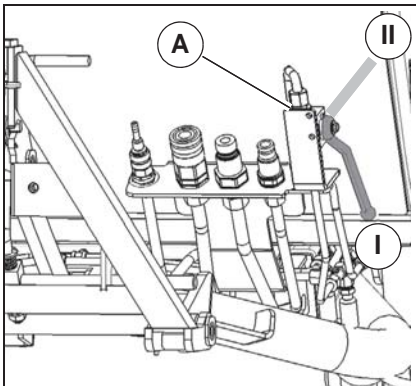

Fig. 126:

Checking the suction mouth lift system

Open or close the valve **Fig. 126-A** of the suction mouth according to the attachment.

- Valve opened (position **I**) for:
 - Vacuum sweeping system (sweeping unit)
- Valve closed (position **II**) for:
 - Sweeping system (front sweeping machine)
 - Lawn mowing system (mower)
 - Snow clearing system (snow blade etc.)
 - Transport system

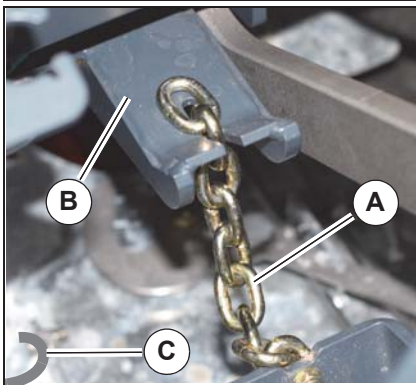

Fig. 127:

Checking the front tool carrier

The adjustment range of the front tool carrier is limited downwards with the chain **Fig. 127-A**. To do this, raise the front tool carrier with the joystick **Fig. 130-70** and hook the chain in the holder **Fig. 127-B**.

- For vacuum sweeping, hook the chain in the holder with the first link.
- For transportation, fix the front tool carrier with the chain in the topmost position.

If the chain is not required, hook it into the hook **Fig. 127-C** (parking position)!

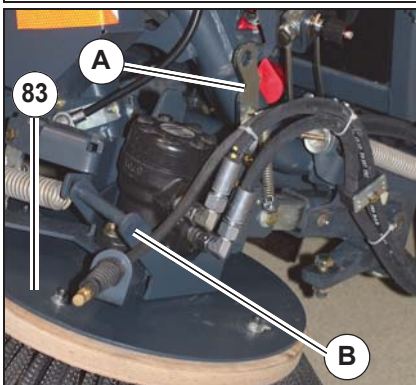

Fig. 128:

Checking the transport protection device

The transport protection device **Fig. 128-A** is located on both sides of the sweeping unit **Fig. 128-83** and has the task of protecting the rotating brushes during transport.

- Locking: Raise the brush arm using the handle **Fig. 128-B**. Lock the brush arm with the hook of the transport protection device.
- Unlocking: Raise the brush arm using the handle **Fig. 128-B**. Unlock the brush arm with the hook of the transport protection device and carefully let the brush arm down.

Checklist – Vacuum sweeping

No.	Description	Reference
1	Driving to the work site	Page 135
2	Switching vacuum sweeping on	Page 135
3	Setting the fixed engine speed	Page 136
4	Starting vacuum sweeping	Page 136
5	Sweeping dry surfaces	Page 136
6	Sweeping wet surfaces	Page 136
7	Sweeping larger objects	Page 137
8	Changing the sweeping width	Page 137
9	Checking the overload protection	Page 137

Driving to the work site

1. Lock the sweeping unit with the transport protection device **Fig. 128-A**, see page 134.
2. Start the vehicle with the ignition switch **Fig. 129-76**.
3. As required, switch on the dipped headlights **Fig. 129-55**, working light **Fig. 129-56** and rotating beacon **Fig. 129-60**.
4. Drive to the work site in the transport mode. The sweeping unit must be in the upper end position for the transport mode. Push the joystick **Fig. 130-70** back for this purpose.
5. Unlock the transport protection device at the work site, see page 134.

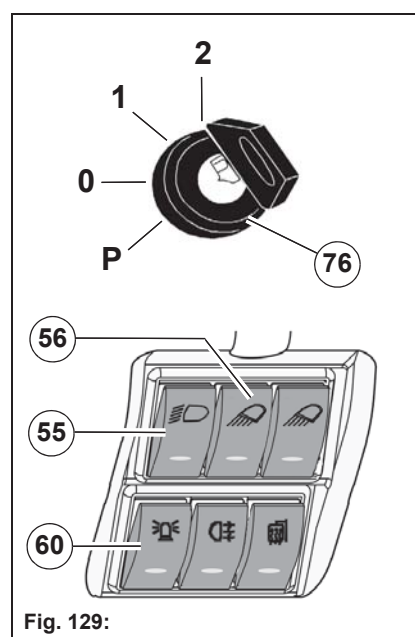

Switching vacuum sweeping on

Switch on the work mode with the Hako button **Fig. 130-71**. The accelerator pedals must be in the neutral position.

The vacuum sweeping system work mode information symbol **Fig. 130-A** is displayed in the multifunction display as a 2-brush system.

The following functions are activated automatically by pressing the Hako button:

- The sweeping unit is lowered (floating position)
- The rotating brush drives are switched on
- The rotating brush speed is activated
- The fresh water pump is switched on
- The circulating water supply is switched on
- The suction fan is switched on

The fresh water supply is interrupted if the driver leaves the driver's seat!

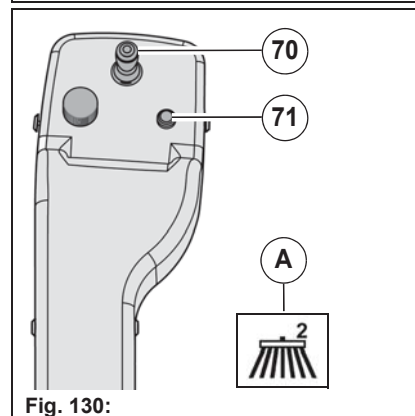

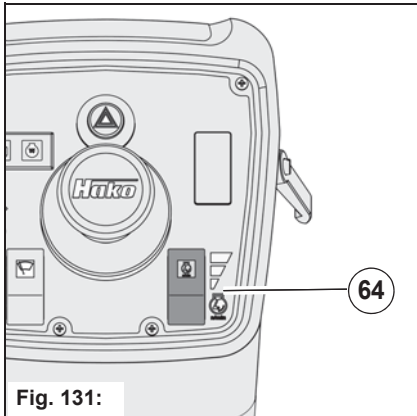

Fig. 131:

Setting the fixed engine speed

The fixed engine speed for the suction fan of the dirt hopper is switched on with the switch **Fig. 131-64**. Set the speed according to the requirements.

Stage	rpm	Use
1 – ECO	1900	In slight contamination
2 – Standard	2250	In medium contamination
3 – Maximum	2630	In heavy contamination

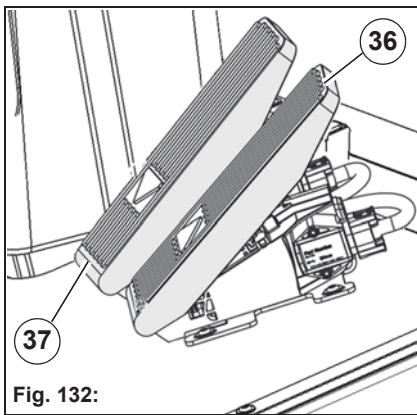

Fig. 132:

Starting vacuum sweeping

The accelerator pedal **Fig. 132-36** is used for continuously changing the speed for driving forwards.

The accelerator pedal **Fig. 132-37** is used for continuously changing the speed for reversing.

Push the accelerator pedal down slowly until the vehicle starts, the speed is increased further by pressing on the pedal.

Slowing down or braking the vehicle: Slowly reduce the pressure on the accelerator pedal, the vehicle slows down or stops.

The vehicle speed in the:

- transport mode is 0 to 25 km/h,
- work mode 15/20/25 km/h according to selected engine speed.

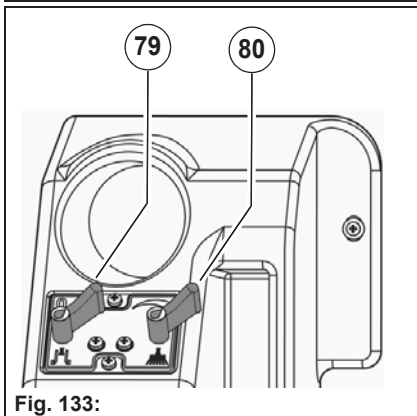

Fig. 133:

Sweeping dry/wet surfaces

To avoid the formation of dust, circulating water and fresh water are available in vacuum sweeping. The circulating water is supplied to the suction duct. The fresh water is supplied to the sweeping unit. The volume of fresh water for the spray nozzles of the sweeping unit is set with the lever **Fig. 133-80**.

Set the volume corresponding to the requirements.

- Less dust formation at the rotating brushes – reduce fresh water volume with the lever.
- Severe dust formation at the rotating brushes – increase the fresh water volume with the lever.

If no circulating water is available, fresh water can be switched on optionally for the suction duct with the lever **Fig. 133-79**.



Note

Dry leaves can be swept best of all at medium suction fan speed. The suction power is sufficient and the coarse sieve on the suction fan of the dirt hopper does not clog so quickly.

Sweeping larger objects

If there are larger objects or coarse dirt (cans, bottles, leaves, etc.) in front of the suction mouth, you can open the coarse material flap on the suction mouth by pressing down on the pedal **Fig. 134-47**.

The pedal can be locked by shifting it to the right when it is operated. Pushing and shifting the pedal to the left with your foot will unlock it.

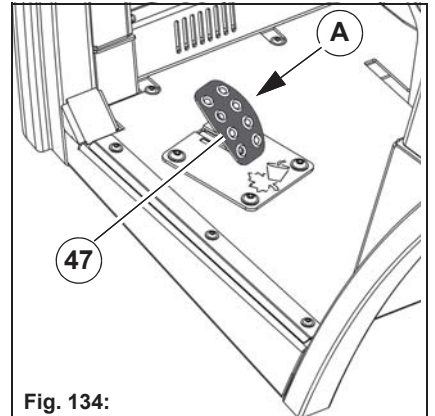

Fig. 134:

Changing the sweeping width

You can change the sweeping width with the joystick **Fig. 135-70** in the armrest.

- Joystick to the right – swivel the sweeping unit out up to the maximum width of 1880 mm.
- Joystick to the left – swing the sweeping unit in to the minimum width of 1380 mm.

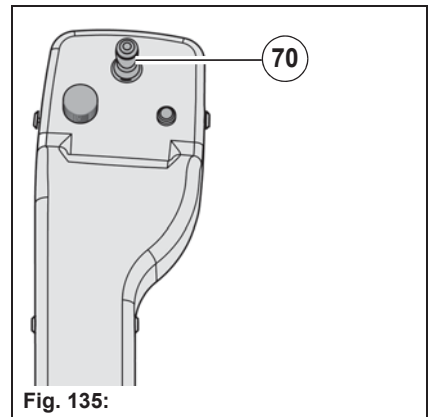



Fig. 135:

Checking the overload protection

The overload protection device **Fig. 136-A** is located on the brush arm of the sweeping unit **Fig. 136-12** and has the task of protecting the sweeping unit in a collision. The overload protection device is unlocked in a collision. Before you can carry on working, you must lock the brush arm again. To do this, swivel the rotating brush and fasten the eye of the Bowden cable **Fig. 136-B** to the hook of the overload protection device.

	<p>Note Check the sweeping unit for damage and secure the sweeping unit again!</p>
---	---

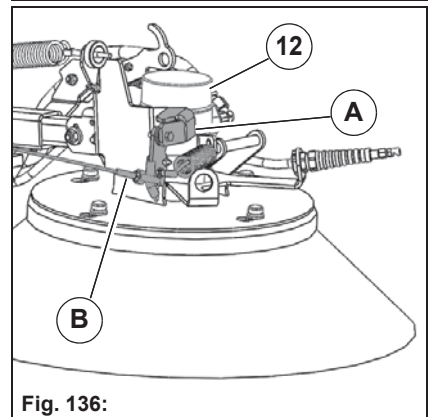

Fig. 136:

Dirt hopper vacuum indicator (optional)

The vacuum indicator **Fig. 137-A** is used for monitoring the suction power, displaying decreasing suction power when the maximum hopper filling level has been reached as well as indicating clogging.

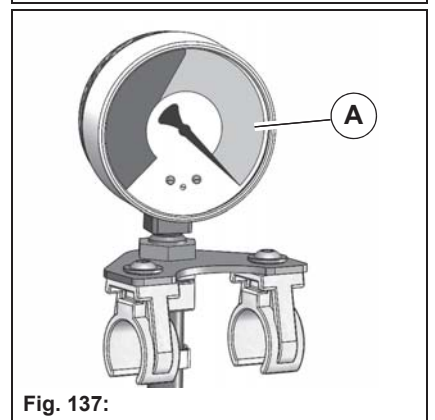

Fig. 137:



Fig. 138:

Circulating water drain (optional)

If vacuum sweeping is done in the rain and too much rain water is taken up, the surplus water can be drained off by the drain. To open, pull the handle **Fig. 138-A** under the front right wheel case. To close, push the handle back in.

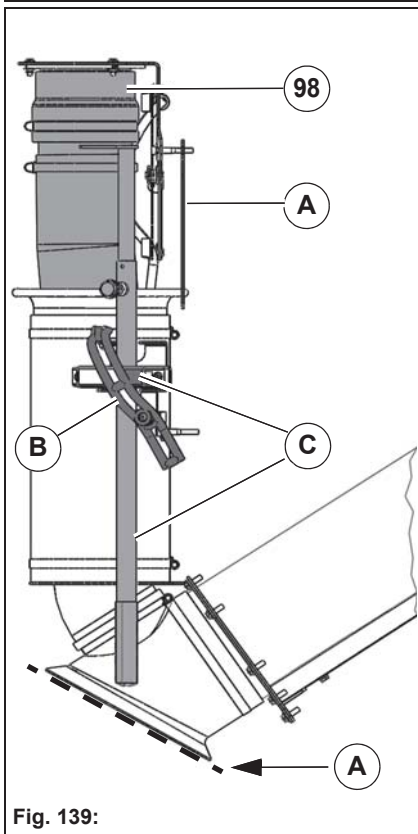

Fig. 139:

Hand suction hose (optional)

The 4 metres long hand suction hose **Fig. 139-98** is used for effectively cleaning places difficult to reach.

1. Start the vehicle and drive to the work site. Engage the parking brake. Switch the suction fan on.
2. If necessary take the insert plate **Fig. 139-A** out from the holder and push it under the rubber seal.
 - Work with the insert plate in the case of heavy soiling. The suction force is increased. The circulating water supply is shut off with the suction mouth lifted.
 - Work without the insert plate in the case of slight soiling. With the suction mouth lowered, additional circulating water is supplied to bind the dust.
3. Loosen the lock **Fig. 139-B** and pull the hand suction hose down and out from the holder.
4. Hold the hand suction hose with the handles **Fig. 139-C** and clean the surface. If required, adjust the handle rod to length with the locking bolt. After cleaning push the hand suction hose against the holder. The hand suction hose withdraws automatically due to the vacuum.
5. If necessary fasten the insert plate back on the holder.
6. Close the handle rod.
7. Lock the hand suction hose again.

Hydraulic hand pump (optional)

The hydraulic hand pump **Fig. 140-123** is used for raising the dirt hopper on failure of the vehicle hydraulics and is located behind the rear flap **Fig. 140-A** of the dirt hopper.

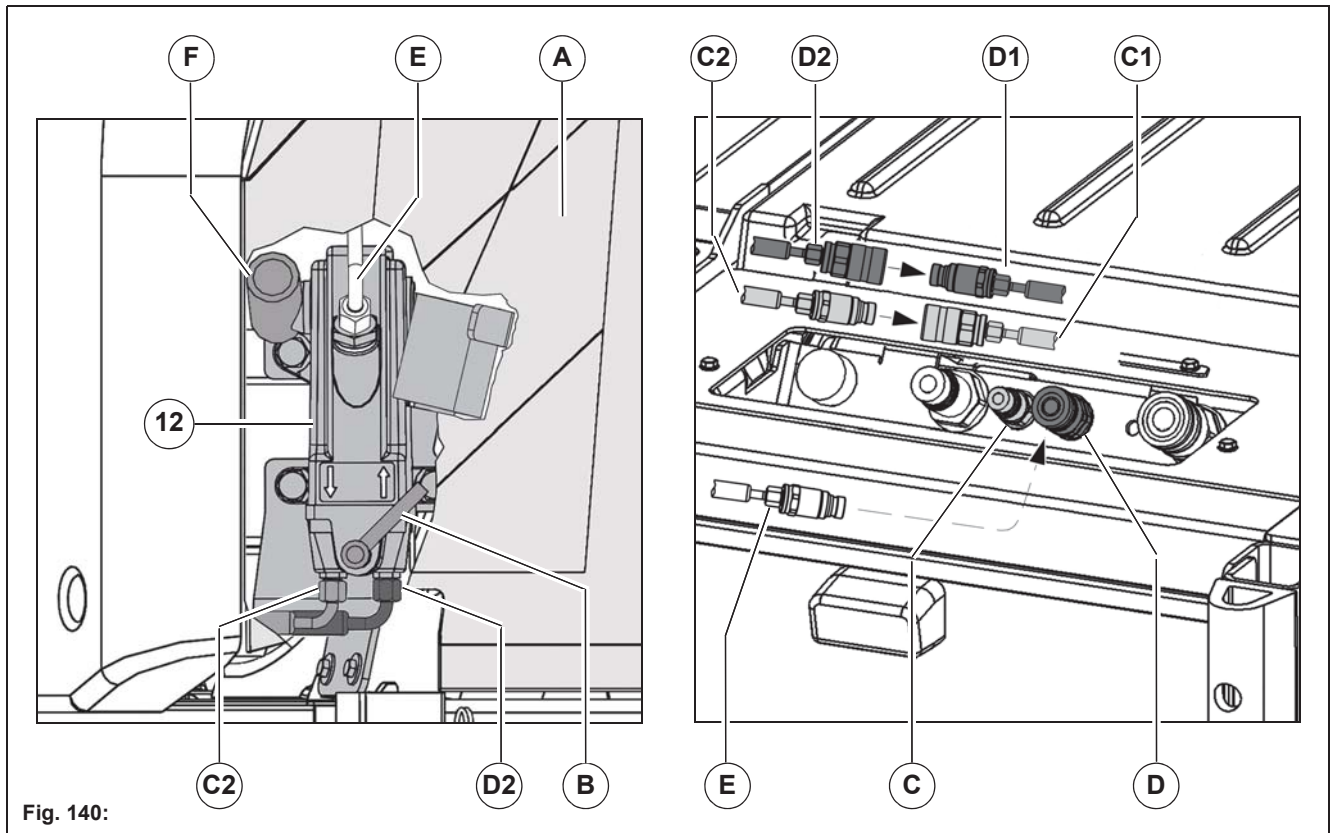

Hydraulic connections of the hand pump:

- Remove the supply hose **Fig. 140-C1** from the supply connection **Fig. 140-C** of the rear wagon.
- Remove the return hose **Fig. 140-D1** from the return connection **Fig. 140-D** of the rear wagon.
- Connect the supply hose **Fig. 140-C1** to the supply hose **Fig. 140-C2** of the hand pump.
- Connect the return hose **Fig. 140-D1** to the return hose **Fig. 140-D2** of the hand pump.
- Connect the hydraulic hose **Fig. 140-E** (hydraulic tank of the hand pump) to the return connection **Fig. 140-D** of the rear wagon.

Operating the hydraulic hand pump:

- Raising the dirt hopper: Lever **Fig. 140-B** to the right
- Lowering the dirt hopper: Lever **Fig. 140-B** to the left
- Insert the pipe of the auxiliary tool **Fig. 60-24** as a lever into the sleeve **Fig. 140-F**

	<p>Note The hydraulic connections must be backfitted for vacuum sweeping!!</p>
---	---

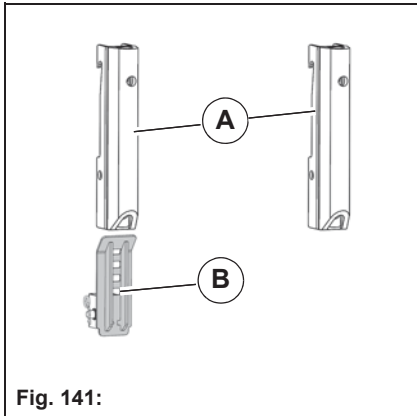

Fig. 141:

Comfort package for the dirt hopper (optional)

The comfort package contains the extended collision protection **Fig. 141-A** and the step **Fig. 141-B**.

Convenient inspection of the dirt hopper is possible with the folding step and the handles on the dirt hopper.

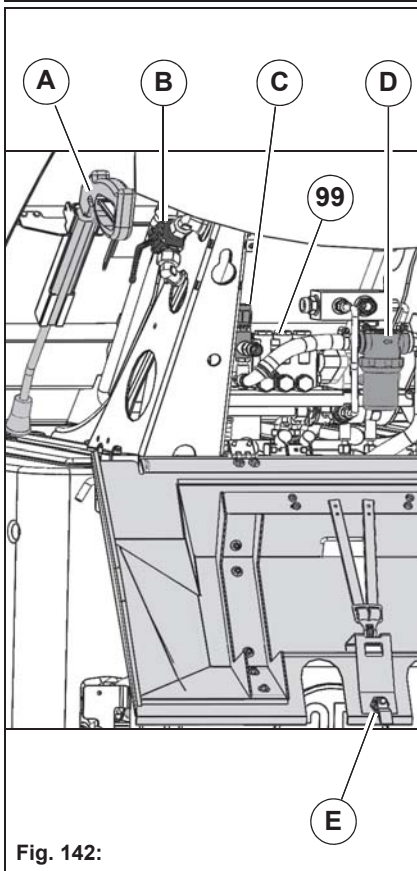

Fig. 142:

High-pressure cleaner (optional)

The high-pressure cleaner **Fig. 142-99** is equipped with a 10 metre long pressure hose. Check the following before starting up:

- Fill the fresh water tank, see page 133.
 - Check the water filter **Fig. 142-D** of the high-pressure cleaner and clean it if necessary.
1. Start the vehicle and drive to the work site. Engage the parking brake. Open the flap **Fig. 142-E**.
 2. Set the changeover valve **Fig. 142-B** to position II.
 - Position I: Suction fan hydraulics
 - Position II: High-pressure cleaner hydraulics
 3. Switch the engine and suction fan on.
 4. Set the pressure controller **Fig. 142-C** to the required working pressure.
 5. Take up the lance **Fig. 142-A** with the pressure hose and clean the surface.

Do not use steam cleaners and high-pressure cleaners for cleaning electrical/electronic components and the engine compartment!
 6. After cleaning, stow the lance and the pressure hose back in the rear wagon and set the changeover valve back.

Checklist – Settings for vacuum sweeping

No.	Description	Reference
1	Adjusting the sweeping unit with the joystick	Page 141
2	Raising/lowering the dirt hopper	Page 141
3	Setting the rotating brush speed	Page 141
4	Switching the fresh water pump on and off	Page 142
5	Switching the suction fan on and off	Page 142

Adjusting the sweeping unit with the joystick

You adjust the sweeping unit with the joystick **Fig. 143-70** in the armrest. The following functions are possible:

- Lift sweeping unit – joystick to the rear
 - The information symbol **Fig. 143-A** appears in the upper end position.
- Lower the sweeping unit (floating position) – joystick to the front
 - The information symbol **Fig. 143-B** appears in the floating position.
- Swivel the sweeping unit out – joystick to the right
- Swivel the sweeping unit in – joystick to the left

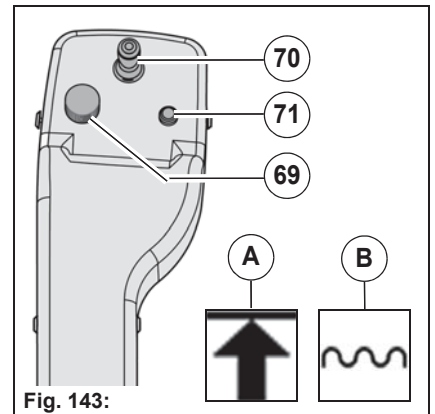

Fig. 143:

Raising/lowering the dirt hopper

The following functions on the dirt hopper are switched on with the button **Fig. 144-74**:

- Button in position I: The dirt hopper is raised until the button is released.
- Button in position II: The dirt hopper is lowered until the button is released.

Raising and lowering the dirt hopper at 2250 rpm (switch for engine fixed speed in stage 2).

The lock must be open before you empty the dirt hopper, see page 143. As long as the dirt hopper is not in its lower end position, the warning symbol **Fig. 144-A** appears.

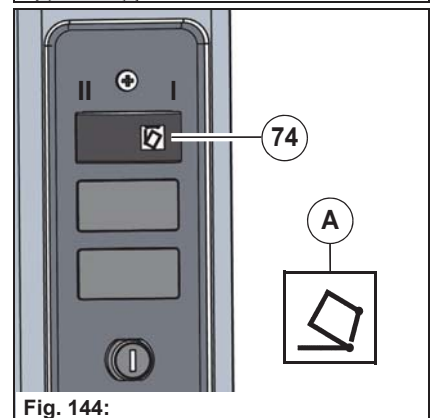

Fig. 144:

Setting the rotating brush speed

Select the A menu in the multifunction display with the turn-push knob **Fig. 143-69**. Change the current value in the brush speed menu item **Fig. 145-A**.

Setting range: 0 to 120 rpm

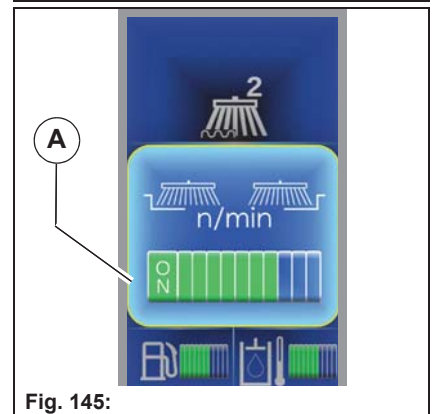

Fig. 145:

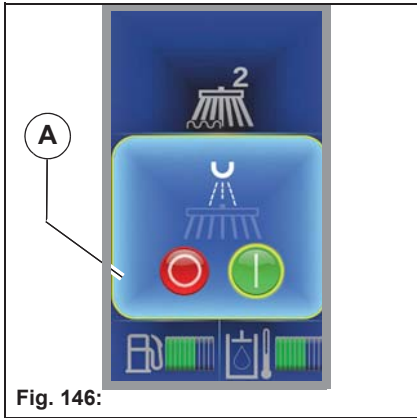

Fig. 146:

Switching the fresh water pump on and off

Select the A menu in the multifunction display with the turn-push knob **Fig. 143-69**. Change the current value in the fresh water menu item **Fig. 146-A**.

Setting range: ON or OFF

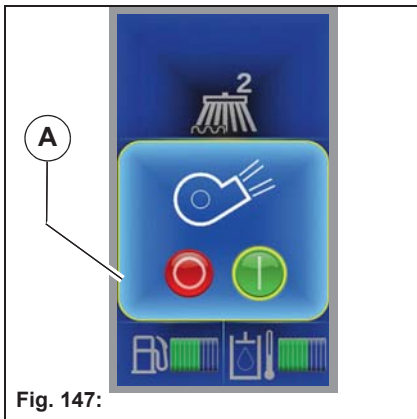

Fig. 147:



Switching the suction fan on and off

Select the A menu in the multifunction display with the turn-push knob **Fig. 143-69**. Change the current value in the suction fan menu item **Fig. 147-A**.

Setting range: ON or OFF

Check-list – Cleaning the vacuum sweeping system

No.	Description	Reference
1	Emptying the dirt hopper	Page 143
2	Cleaning the sweeping unit	Page 144
3	Cleaning the dirt hopper and circulating water system	Page 145
4	Emptying the fresh water tank	Page 145
5	Emptying the circulating water tank	Page 145

	<p>Caution</p> <ul style="list-style-type: none"> Do not exceed the permissible total weight. There is a risk of accidents! Frequently check the filling level of the dirt hopper. Switch the suction fan off for this! The lid of the dirt hopper must not be opened when the suction fan is running. There is a risk of injury! Do not use steam cleaners and high-pressure cleaners for cleaning electrical/electronic components and the engine compartment!
	<p>Note</p> <ul style="list-style-type: none"> The cleaning work listed below must be done after every emptying, at least once daily.

Emptying the dirt hopper

- Lock the sweeping unit, start the vehicle with the ignition switch and drive to a suitable cleaning place.
- Reverse carefully to the offloading place and engage the parking brake. Switch the suction fan off!
- Before emptying the dirt hopper **Fig. 148-85** open the lock **Fig. 148-A** of the lid.
 - Pull the handle out from the lock to open.
 - Push the handle into the lock to close.
- Raise and empty the dirt hopper with the button **Fig. 148-74**.
- Lower the dirt hopper and lock the lid again.

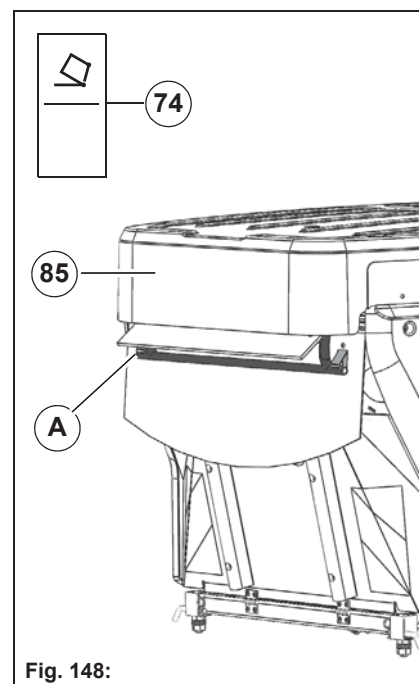

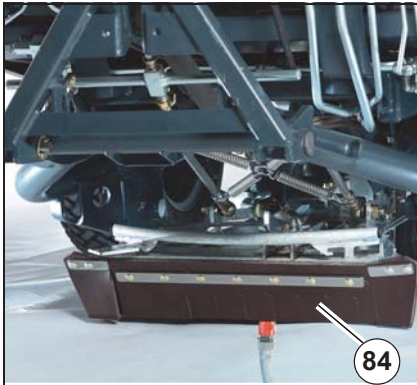

Fig. 149:

Cleaning the suction mouth

1. Lock the sweeping unit with the transport protection device, see page 134. Drive the vehicle to a suitable cleaning place.
 2. Select the A menu in the multifunction display with the turn-push knob. Switch the suction fan on in the suction fan menu item.
 3. Push a water hose into the suction mouth **Fig. 149-84** and loosen the dirt with the water jet. The dirt is drawn with the water into the dirt hopper.
 4. Empty the dirt hopper, see page 143.
- In the case of heavy soiling, dismantle and clean the suction mouth, see page 127.

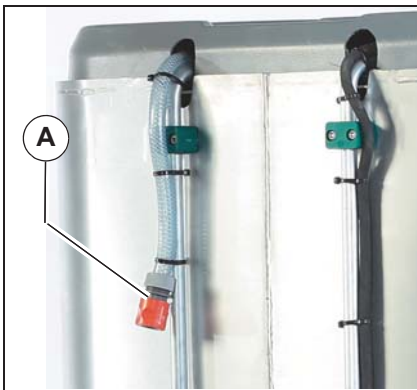

Fig. 150:

Cleaning the suction fan

1. Lock the sweeping unit with the transport protection device, see page 134. Drive the vehicle to a suitable cleaning place.
2. Connect a water hose to the water connection **Fig. 150-A** of the dirt hopper.
3. Push the Hako button **Fig. 8-71** and let the water be drawn as required by the suction fan into the dirt hopper.
4. Open the lid of the dirt hopper and raise the dirt hopper up to the end stop with the button **Fig. 8-74** and drain off the water taken up!

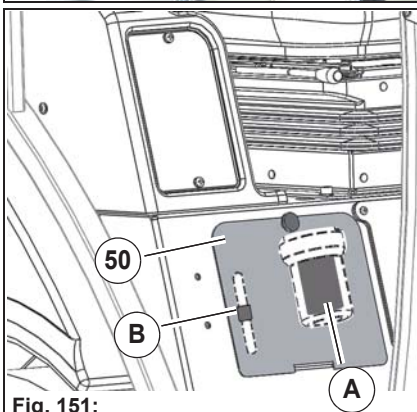

Fig. 151:

Cleaning the sieve filter reducing piece

In the driver's cab under the driver's seat behind the cover plate **Fig. 151-50** are located the sieve filter **Fig. 151-A** and the reducing piece **Fig. 151-B** of the water pump. Unscrew the filter housing, check the sieve filter and the reducing piece for openness and clean if necessary.

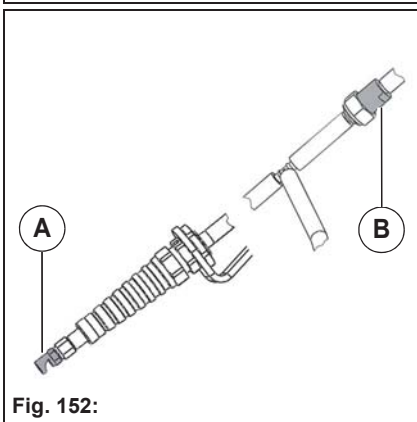

Fig. 152:

Cleaning spray nozzles and ball valve filter

The spray nozzles **Fig. 152-A** for the rotating brushes are located on the sweeping unit. A ball valve filter is located in the filter holder **Fig. 152-B** in front of a distributor. Dismantle and clean the spray nozzles and ball valve filter.

Cleaning the dirt hopper and circulating water system

1. Lock the sweeping unit with the transport protection device, see page 134. Drive the vehicle to a suitable cleaning place and empty it.
2. Half raise the dirt hopper and open the lock **Fig. 153-D** of the sump flap. Then bring the dirt hopper into its end position.
3. Clean the dirt hopper from the inside with a water hose or a high-pressure cleaner. Pay special attention to the lateral filter sieve **Fig. 153-A** and the filter sieve **Fig. 153-B** in the lid. Clean with the auxiliary tool as required or remove the contaminated filter sieve.
4. When the dirt hopper is raised, the valve of the settling tank **Fig. 153-C** opens. Flush the circulating water system thoroughly with water.
5. Half lower the dirt hopper and close the sump flap lock.
6. Lower the sweeping unit fully with the joystick **Fig. 8-70** and let the water run until clear water emerges at the suction mouth.

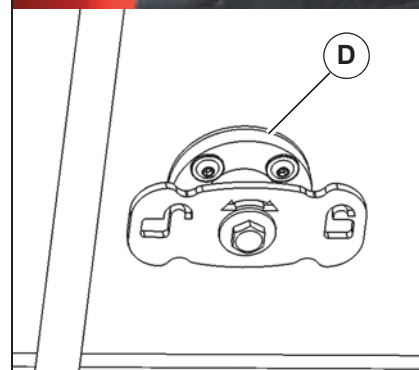
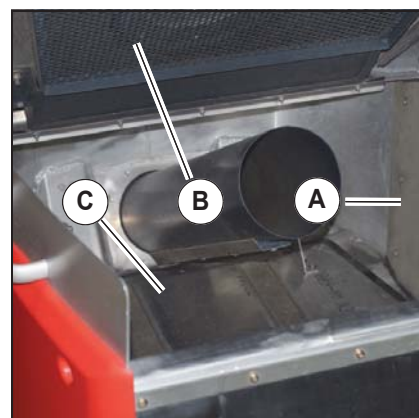

Fig. 153:

Draining the fresh water



Note

At temperatures below 0 degrees (risk of frost) drain the water out from all water-conducting components.

1. Lock the sweeping unit with the transport protection device, see page 134. Drive the vehicle to a suitable cleaning place.
2. Unscrew the drain screws **Fig. 154-A** on both sides of the fresh water tank **Fig. 154-43** and empty the tank.
3. Also empty the sieve filter **Fig. 151-B**.

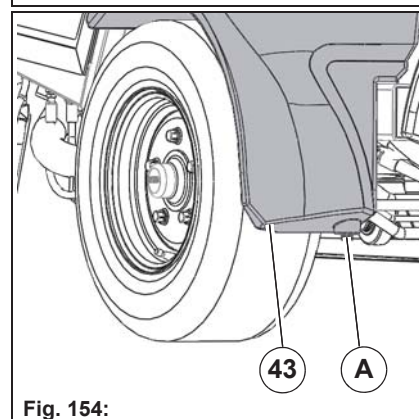

Fig. 154:

Draining the circulating water



Note

At temperatures below 0 degrees (risk of frost) drain the water out from all water-conducting components.

1. Lock the sweeping unit with the transport protection device, see page 134. Drive the vehicle to a suitable cleaning place.
2. Lower the sweeping unit with the joystick **Fig. 8-70** and drain off the circulating water.

6.1.5 Technical data



Fig. 155:

Vacuum sweeping system

Dimensions	Unit	
Length	mm	3899
Width	mm	1074 to 1200
Height	mm	2269
Sweeping width	mm	1380 to 1880
Weights and loads	Unit	
Basic unit empty weight with vacuum sweeping system without water	kg	1780
Basic unit empty weight with vacuum sweeping system ready for operation	kg	1930
Dirt hopper load	kg	500
Sweeping unit/dirt hopper	Unit	
Brush diameter	mm	720
Brush speed	rpm	0 to 120
Dirt hopper total volume	litre	997
Circulating water system settling tank	litre	38
Fresh water tank capacity	litre	150
Noise emission values	Unit	Value
The sound pressure level at the workplace (LpA) measured under the customary conditions of use at 1900 rpm according to Directive 2006/42/EC with measuring standard DIN EN ISO 11201 is: Measuring uncertainty KpA	dB(A)	72 2
The sound pressure level at the workplace (LpA) measured under the customary conditions of use at 2250 rpm according to Directive 2006/42/EC with measuring standard DIN EN ISO 11201 is: Measuring uncertainty KpA	dB(A)	78 2
The sound pressure level at the workplace (LpA) measured under the customary conditions of use at 2630 rpm according to Directive 2006/42/EC with measuring standard DIN EN ISO 11201 is: Measuring uncertainty KpA	dB(A)	79 2
The sound pressure level at the workplace (LpA) measured under the customary conditions of use at 1900 rpm with the sound insulation package according to Directive 2006/42/EC with measuring standard DIN EN ISO 11201 is: Measuring uncertainty KpA	dB(A)	72 2
The sound power level (LWAd) measured under the customary conditions of use at 1900 rpm according to Directive 2000/14/EC with measuring standard DIN EN ISO 3744 is:	dB(A)	100
The sound power level (LWAd) measured under the customary conditions of use at 2250 rpm according to Directive 2000/14/EC with measuring standard DIN EN ISO 3744 is:	dB(A)	103
The sound power level (LWAd) measured under the customary conditions of use at 2630 rpm according to Directive 2000/14/EC with measuring standard DIN EN ISO 3744 is:	dB(A)	107
The sound power level (LWAd) measured under the customary conditions of use at 1900 rpm with sound insulation package according to Directive 2000/14/EC with measuring standard DIN EN ISO 3744 is:	dB(A)	98

6.1.6 Maintenance

Maintenance plan

Weekly

- Checking wear and damage at the suction mouth
 - Checking the suction mouth setting, adjusting if necessary
 - Checking the suction hose for wear and seating
 - Checking the seal between suction duct and dirt hopper
 - Checking the circulating water system
 - Checking the coarse material flap on the suction mouth
- Checking wear and damage of the sweeping unit
 - Checking the sweeping level, adjusting if necessary
 - Checking and if necessary cleaning the sieve filter and reducing piece of the fresh water system
- Checking lubricating points, see page 152
 - Cleaning the machine at the vacuum sweeping system: suction mouth, suction pipe, suction fan and circulating water system

Maintenance work



Warning

- Always bring and insert the safety strut **Fig. 156-A** of the dirt hopper into the upper position during maintenance and cleaning work under the raised dirt hopper. There is a risk of injury!
- Staying in the danger area is forbidden when raising and lowering the dirt hopper!

Inserting the safety strut

Raise the emptied dirt hopper with the button **Fig. 156-74** up into its end position.

Hinge over the safety strut **Fig. 156-B**.

Lower the dirt hopper with the button **Fig. 156-74** and insert the safety strut in the recess **Fig. 156-A**.

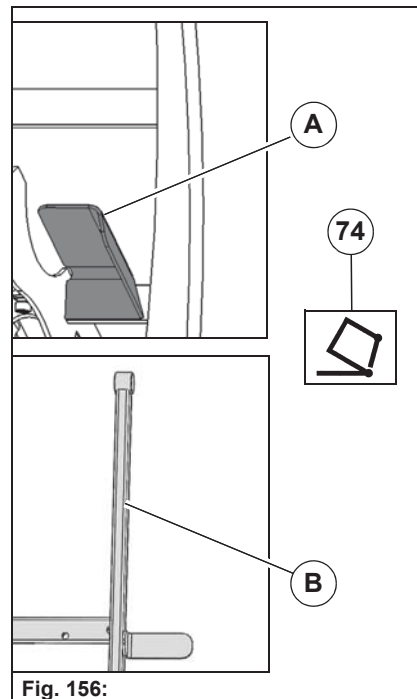

Fig. 156:

Checking the rotating brushes

Check the rotating brushes **Fig. 157-A** daily. Adjust the rotating brush pressure as required, see page 150. If the rotating brush pressure is changed, the sweeping level must be reset, see page 150.

Change worn out rotating brushes.

To do this, raise the sweeping unit with the joystick **Fig. 160-70**. Remove the caps **Fig. 157-B** and loosen the nuts located below. Turn the rotating brush counter-clockwise and push it downwards.

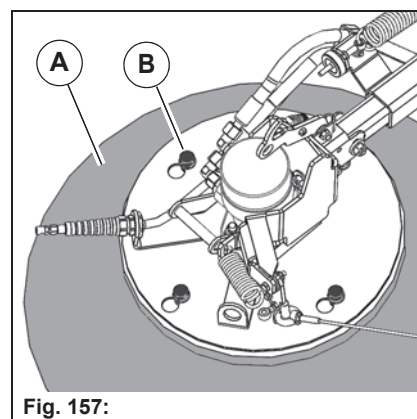

Fig. 157:

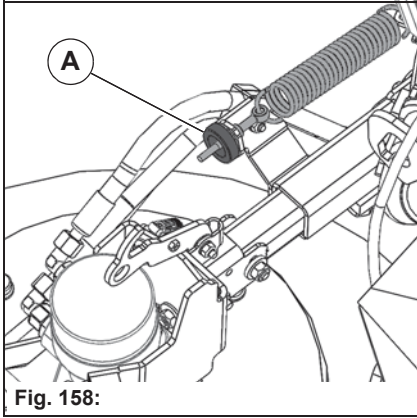

Fig. 158:

Checking the rotating brush pressure

Adjust the rotating brush pressure with the adjusting screw **Fig. 158-A**. The sweeping level must be adjusted with increasing wear.

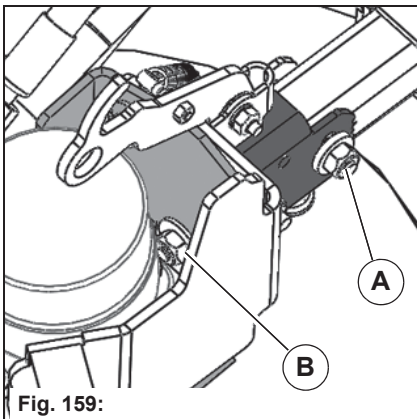

Fig. 159:

Checking the sweeping level

The sweeping level **Fig. 160-A** is adjusted in the factory with the screws **Fig. 159-A** and **Fig. 159-B**.

1. Raise the sweeping unit with the joystick **Fig. 160-70**.
2. Drive over a level surface covered with dust or chalk.
3. Lower the sweeping unit and let the rotating brushes turn for a short time.
4. With correctly adjusted sweeping level, the following pattern must result in driving direction:
 - Right rotating brush from 10 a.m. to 4 p.m.
 - Left rotating brush from 8 a.m. to 2 p.m.

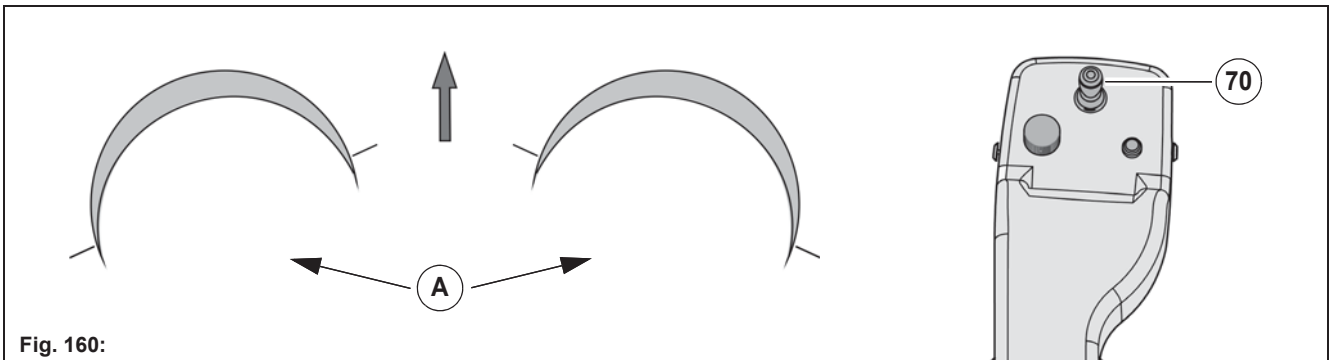

Fig. 160:

Checking the suction mouth sealing strips

Check the sealing strips **Fig. 161-A** of the suction mouth daily. Immediately replace defective seals, also on the coarse material flap, since the suction power is reduced.

The gap **Fig. 161-B1** between the side sealing strip and ground must be approx. 5 mm.

The gap **Fig. 161-B2** between the rear sealing strip and ground must be approx. 10-15 mm.

In the case of wear of the sealing strips, fasten the rollers **Fig. 161-C** in the next higher hole **Fig. 161-D**.

Make sure that the gap size is maintained!

Make sure that the rollers are again fastened in the lower hole after the sealing strips have been changed!

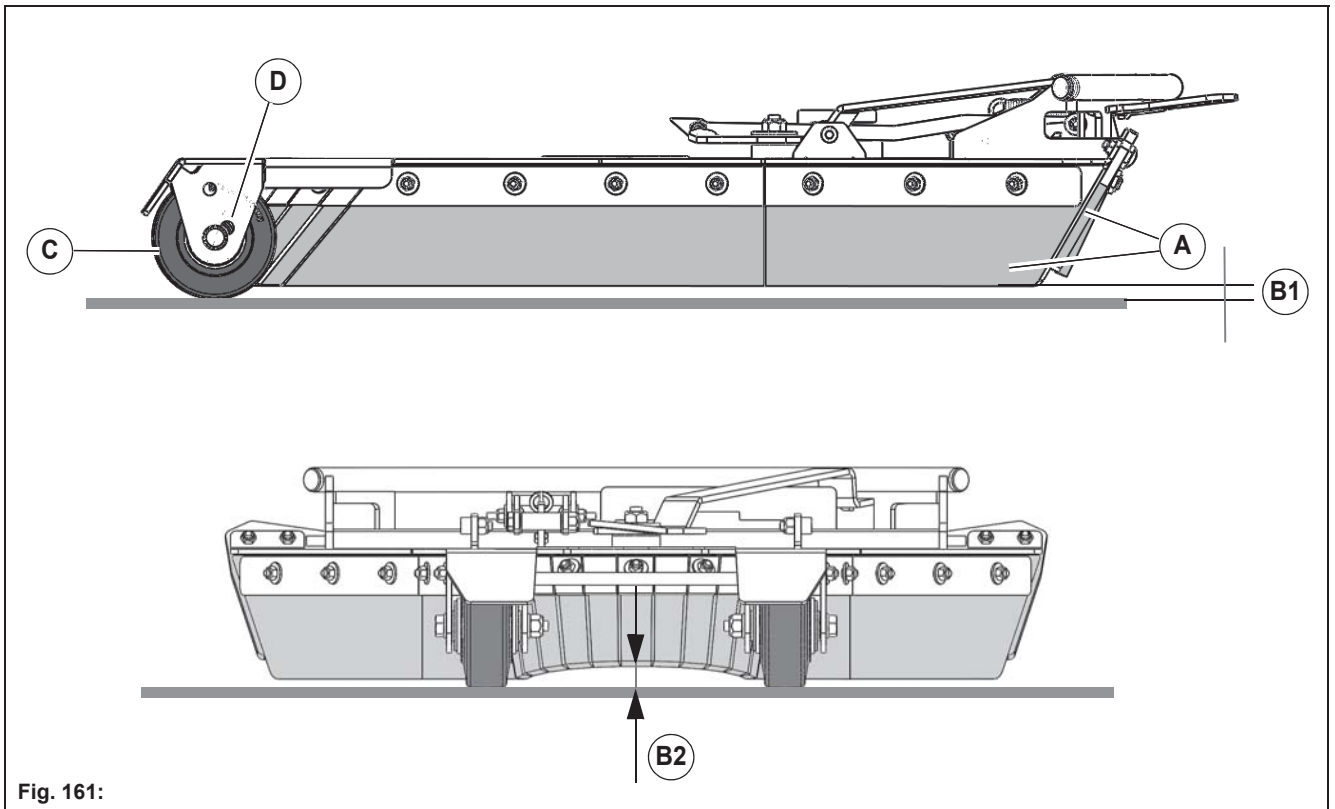

Fig. 161:

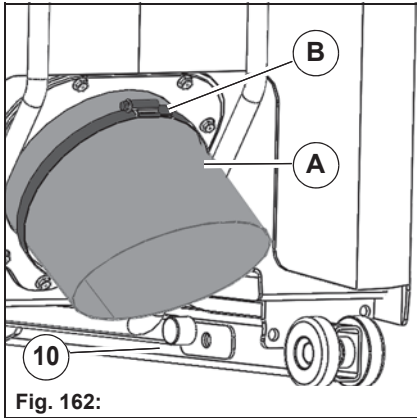

Fig. 162:

Checking the suction duct seal

Check the suction duct seal **Fig. 162-A** on the dirt hopper daily. Immediately replace a defective suction duct seal, since the suction power is reduced. To do this, loosen the clamping band **Fig. 162-B**.

Lubrication points

Check the lubrication points weekly.

Grease: Mobilgrease MP

- Horizontal brush suspension left/right (2 pcs.) **Fig. 163-A**
- Vertical brush suspension left/right (2 pcs.) **Fig. 163-B**
- Brush deflection left/right (2 pcs.) **Fig. 163-C**
- Brush swivelling device (2 pcs.) **Fig. 163-D**
- Dirt hopper bearing left/right (2 pcs.) **Fig. 156-E**
- Dirt hopper lifting cylinder left/right (4 pcs.) **Fig. 163-F**

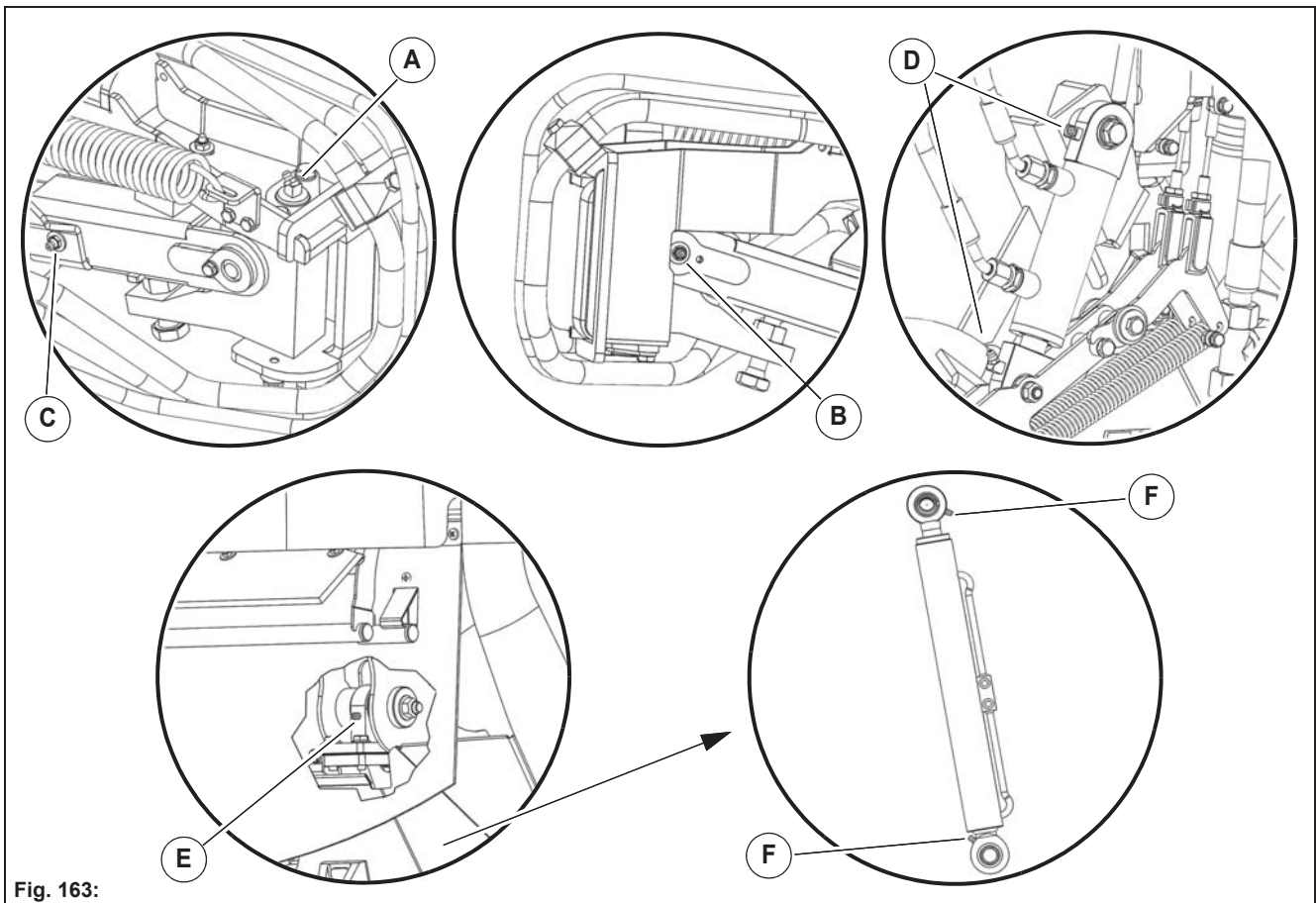

Fig. 163:

6.1.7 Troubleshooting

The fresh water supply is interrupted	Remedy	Reference
The fresh water tank is empty	Fill the fresh water tank according to the indicator	Page 133
The fresh water system is clogged	Cleaning the sieve filter and reducing piece Cleaning the spray nozzles and ball valve filter	Page 144 Page 144
The circulating water supply is interrupted	Remedy	
The circulating water system is empty	Filling the dirt hopper up to the mark	Page 133
The circulating water system is clogged	Flushing the circulating water system with water	Page 145
The sweeping power is reduced	Remedy	Reference
The coarse material flap is still open	Closing the coarse material flap	Page 137
The dirt hopper is full	Emptying the dirt hopper	Page 143
The flap of the dirt hopper is not locked	Locking the dirt hopper	Page 143
The suction fan is contaminated	Cleaning the suction fan	Page 144
The dirt hopper and sieve are contaminated	Cleaning the dirt hopper	Page 145
The circulating water system is contaminated	Cleaning the circulating water system	Page 145
The vacuum system is clogged	Cleaning the suction mouth with the auxiliary tool	Page 144
The suction mouth sealing strips are defective	Checking the suction mouth sealing strips	Page 151
The suction duct seal is defective	Checking the suction duct seal	Page 152
The sweeping level is not adjusted correctly	Checking the sweeping level	Page 150
The rotating brush pressure is not correctly set	Checking the rotating brush pressure	Page 150
The hand suction hose is not correctly set on	Setting on the hand suction hose correctly	Optional

6.1.8 Accessories

Your authorised Hako dealer is available to you at any time to answer questions on accessories for the vacuum sweeping system.

6.2 Lawn mowing system

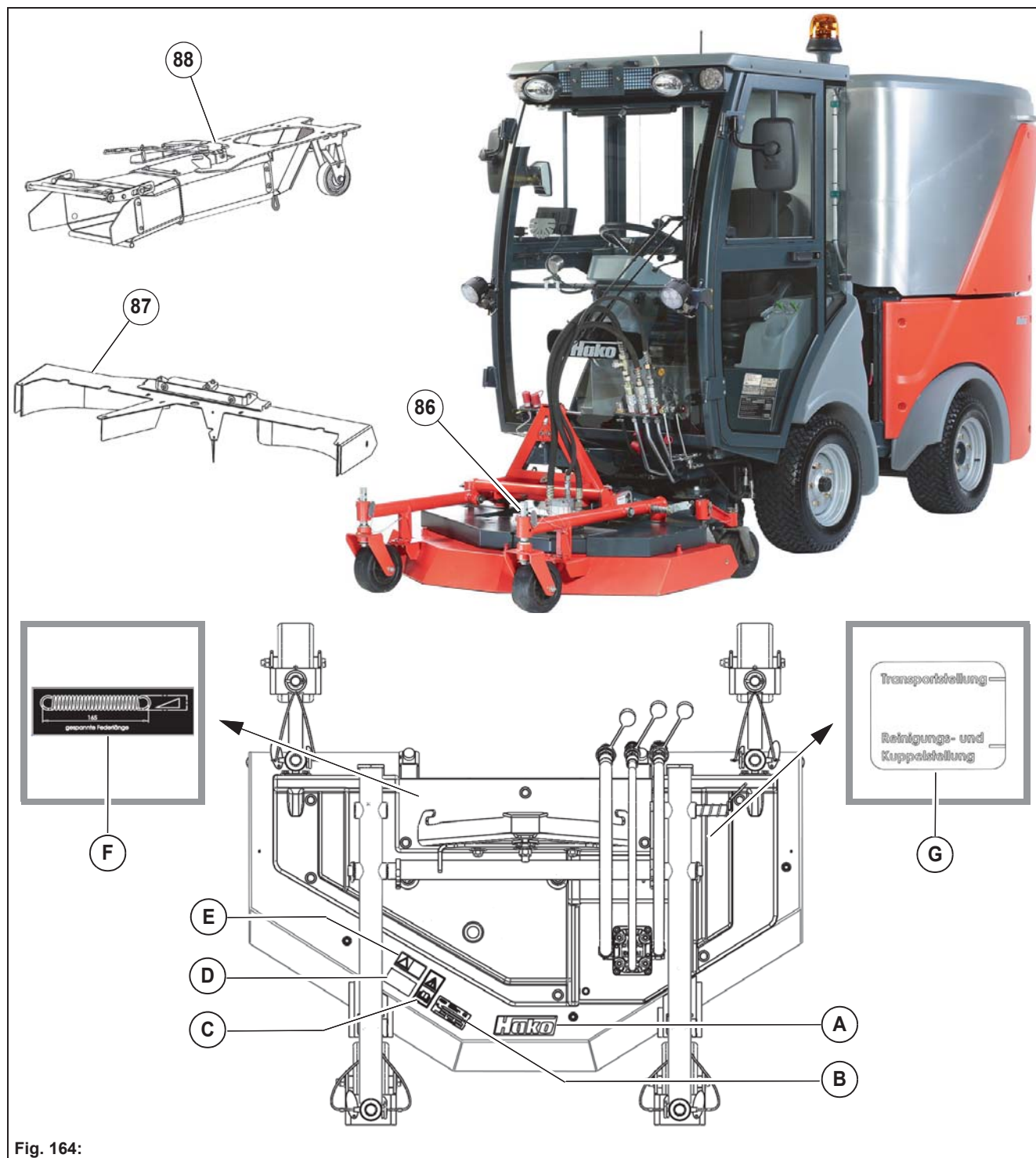

Fig. 164:

Item	Designation	Type
86	Mower	810100
87	Vacuum system	810110
88	Suction nozzles	147810

6.2.1 Labels on the unit

Hako logo

The Hako logo **Fig. 164-A** is located on the mower cover.

Type plate

The type plate **Fig. 164-B** is located on the right side of the mower.

Label – Read operating manual

The Read operating manual label **Fig. 164-C** is located on the right side of the mower.

Rotating parts label

The Rotating parts label **Fig. 164-D** is located on the right side of the mower.

Keep distance label

The Keep distance label **Fig. 164-E** is located on the right side of the mower.

Spring length label

The Spring length label **Fig. 164-F** is located on the right side of the mower under the cover.

Transport and work position

The Transport and work position label **Fig. 164-G** is located on the left side of the mower under the cover.

6.2.2 Mowing system safety instructions



Warning

- You must consult Hako before attaching other attachments not approved by Hako!
- The labels attached to the vehicle provide important information for safe operation. Renew labels that are no longer legible or present.
- Spare parts must be original spare parts to guarantee safety.
- Always wear protective gloves when changing blades! There is a risk of injury!
- Immediately renew damaged or highly unbalanced mowing blades to avoid damage to the blade bearings.
- Before reinstalling, balance the blades and check them for out of true in height.
- Adopt measures against erroneous starting and unwanted movement. Pull out the ignition key.
- The safety regulations for the Citymaster 650 must be complied with absolutely.
- The V-belt is self-tensioning by spring force. Do not hook tension springs in or out with your bare hand. Risk of crushing!
- The lawn mowing system may be operated only in connection with the Citymaster 650.
- The lawn mowing system may be put into operation only with the suction nozzle raised! Refer to mounting the mower on page 156!

6.2.3 Mounting

Mounting the mower

1. Place the vehicle on a level surface and hold it with the parking brake.
2. Fit the suction nozzle **Fig. 165-88**, see page 127.
3. Fit the suction system **Fig. 165-87** with six flat round screws **Fig. 165-L** to the lawn mower **Fig. 165-86**.
4. Unlock the locking hook **Fig. 165-A** and locking rod **Fig. 165-B** on the front tool carrier.
5. Align the mower **Fig. 165-86** centrally and in alignment with the front tool carrier.
6. Raise the front tool carrier **Fig. 165-12** with the joystick **Fig. 165-70** and attach the mower.
7. Lock the mower with locking hook and locking rod.
8. Close the valve **Fig. 165-J** for the suction mouth lift system!
9. Lock the suction nozzle **Fig. 165-88** at the suction system with the bow **Fig. 165-K**.
10. Make the connections.
 - Mower hydraulic motors – return = **Fig. 165-G**
 - Mower hydraulic motors – supply = **Fig. 165-H**
 - Leakage oil pipe = **Fig. 165-I**

Dismantling is in the reverse order.

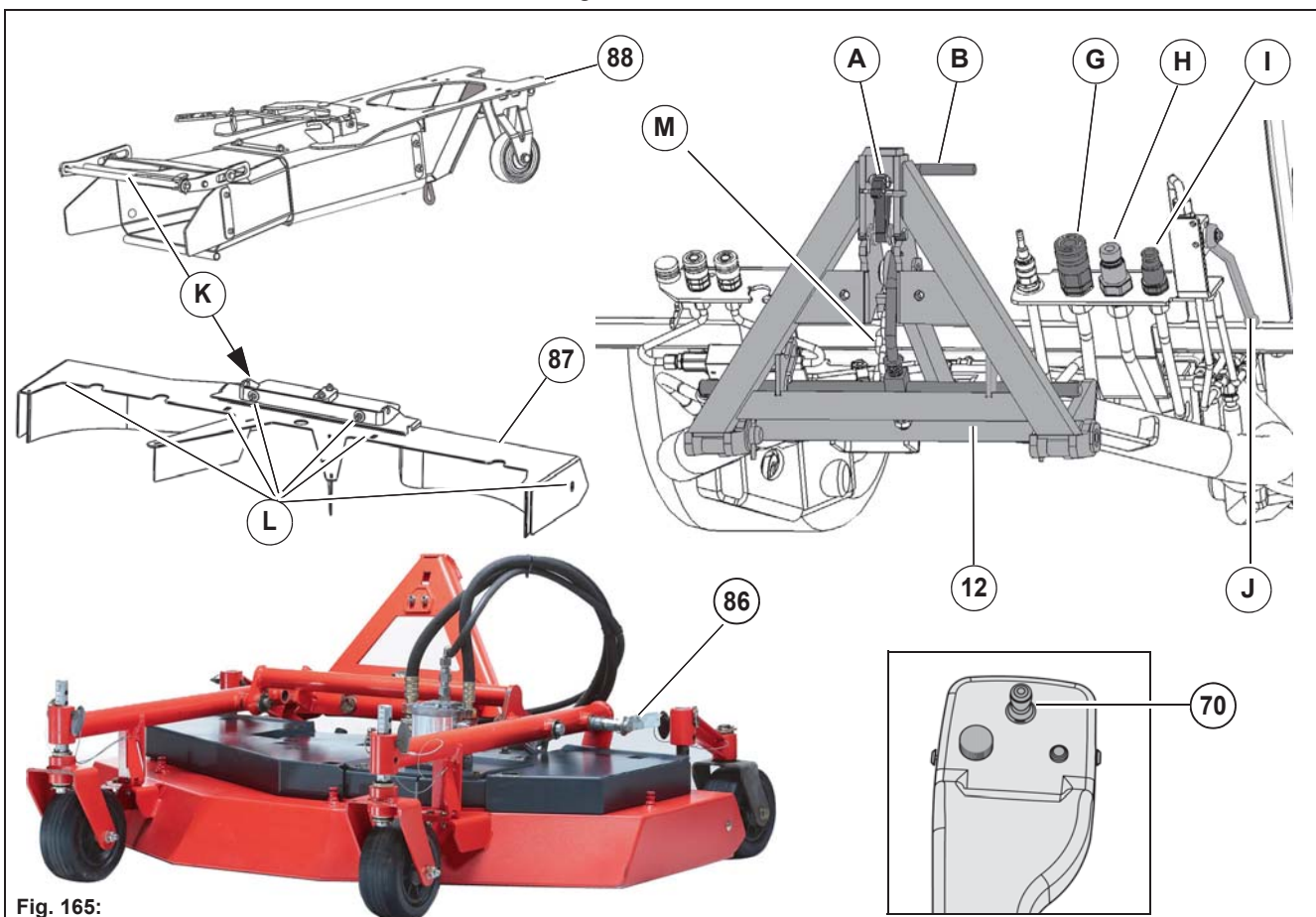

Fig. 165:

6.2.4 Operation

Check-list – Before start-up of the mowing system

No.	Description	Reference
1	Checking the suction mouth lift system	Page 134
2	Checking the front tool carrier	Page 134
3	Checking the transport protection device	Page 157
4	Adjusting the cutting height	Page 157
5	Checking and if necessary changing the mowing blades	Page 161
6	Checking and if necessary changing the V-belt	Page 161

Checking the transport protection device

The transport protection device is located on the left side of the mower. The mower is set for the relevant operation with the mounting bolt

Fig. 166-A. The following settings are possible:

- Mowing: Take the mounting bolt out from the mounting position, see the illustration (the mower must float freely).
- Transport: The mounting bolt must secure the mower in the upper position **Fig. 166-B**.
- Cleaning: The mounting bolt must secure the mower in the lower position **Fig. 166-C**.

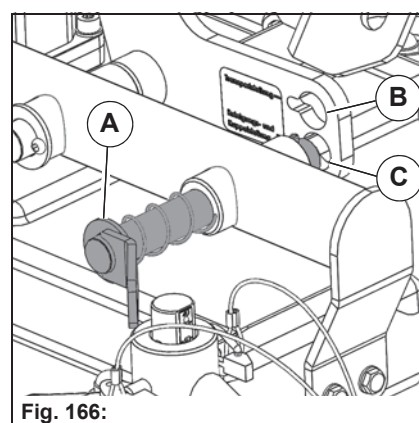

Fig. 166:

Adjusting the cutting height

1. Place the vehicle on a level surface and hold it with the parking brake. Raise the mower with the joystick **Fig. 169-70**. Switch the engine off and pull out the ignition key.
2. Pull the mounting bolt **Fig. 167-C** out and push the bolt **Fig. 167-A** of the wheel fork into the bush **Fig. 167-B** of the wheel spar until the wanted cutting height is set. You can adjust the cutting height centimetre by centimetre with the two mounting holes in the bush.
3. You can read off the cutting height on the scale **Fig. 167-D**.
4. Secure the set cutting height with the mounting bolt.

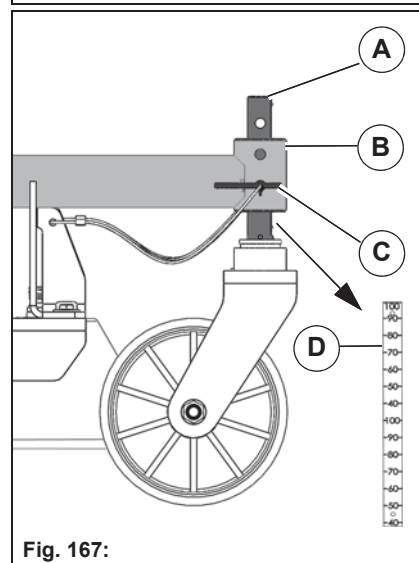

Fig. 167:



Note

The setting of the cutting height must be the same for all wheels.
If the grass is very long and wet, you are recommended firstly to cut high and then to cut low once again.

Checklist – Mowing

No.	Description	Reference
1	Driving to the work site	Page 158
2	Switching mowing on	Page 158
3	Setting the fixed engine speed	Page 159
4	Starting mowing	Page 159

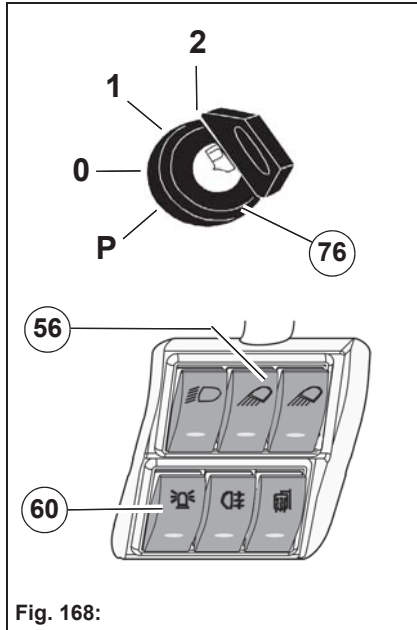

Driving to the work site

1. Bring the mower into the transport position, see page 157.
2. Start the vehicle with the ignition switch **Fig. 168-76**.
3. If required, switch on the working light **Fig. 168-56** and the rotating beacon **Fig. 168-60**.
4. Drive to the work site in the transport mode. The mower must be in the upper end position for the transport mode. Push the joystick **Fig. 169-70** back for this purpose.
5. At the work site bring the mower into its working position, see page 157.

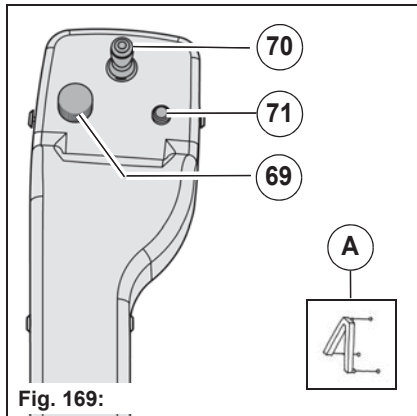

Switching the mower on

1. Switch on the work mode with the Hako button **Fig. 169-71**. The accelerator pedals must be in the neutral position. The coupling triangle work mode symbol appears in the multifunction display **Fig. 169-A**.
2. Switch on the hydraulic circuit. Switch on the hydraulic circuit I for front attachments and hydraulic circuit II for rear attachments (suction fan) with the turn-push knob **Fig. 169-69**.
3. Lower the mower with the joystick **Fig. 169-70**. The following functions are activated:
 - The mower is lowered (floating position).
 - Mowing is switched on.

Setting the fixed engine speed

The fixed engine speed is set with the switch **Fig. 170-64**. Set the speed according to the requirements.

Stage	rpm	Use
1 – ECO	1900	Not for mowing
2 – Standard	2250	For medium load
3 – Maximum	2630	For high load

The height of the speed has a direct influence on the circumferential speed of the mowing blades!

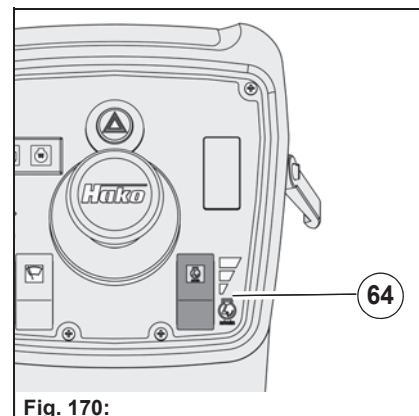

Fig. 170:

Starting mowing

The accelerator pedal **Fig. 171-36** is used for continuously changing the speed for driving forwards.

The accelerator pedal **Fig. 171-37** is used for continuously changing the speed for reversing.

Push the accelerator pedal down slowly until the vehicle starts, the speed is increased further by pressing on the pedal.

Slowing down or braking the vehicle: Slowly reduce the pressure on the accelerator pedal, the vehicle slows down or stops.

The vehicle speed in the work mode is 15/20/25 km/h according to the selected engine speed.

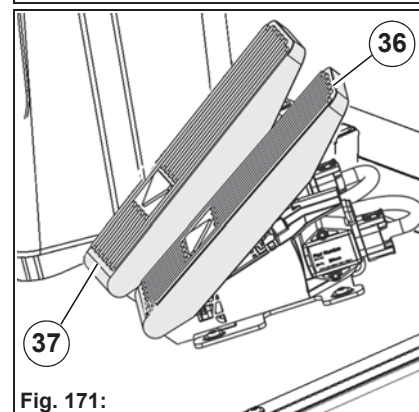

Fig. 171:



Attention

Before you leave the vehicle, the attachment must be lowered to the ground!

6.2.5 Technical data

Mower	Unit	
Length	mm	1155
Width	mm	1270
Height	mm	660
Working width	mm	1220
Weight (mower, vacuum system and suction nozzles)	kg	172
Cutting height in 10 mm steps	mm	40-100
Blade speed	rpm	3070

6.2.6 Maintenance

Maintenance plan

Daily
• Checking wear and damage to the mower
Weekly
• Checking lubrication points

Maintenance work

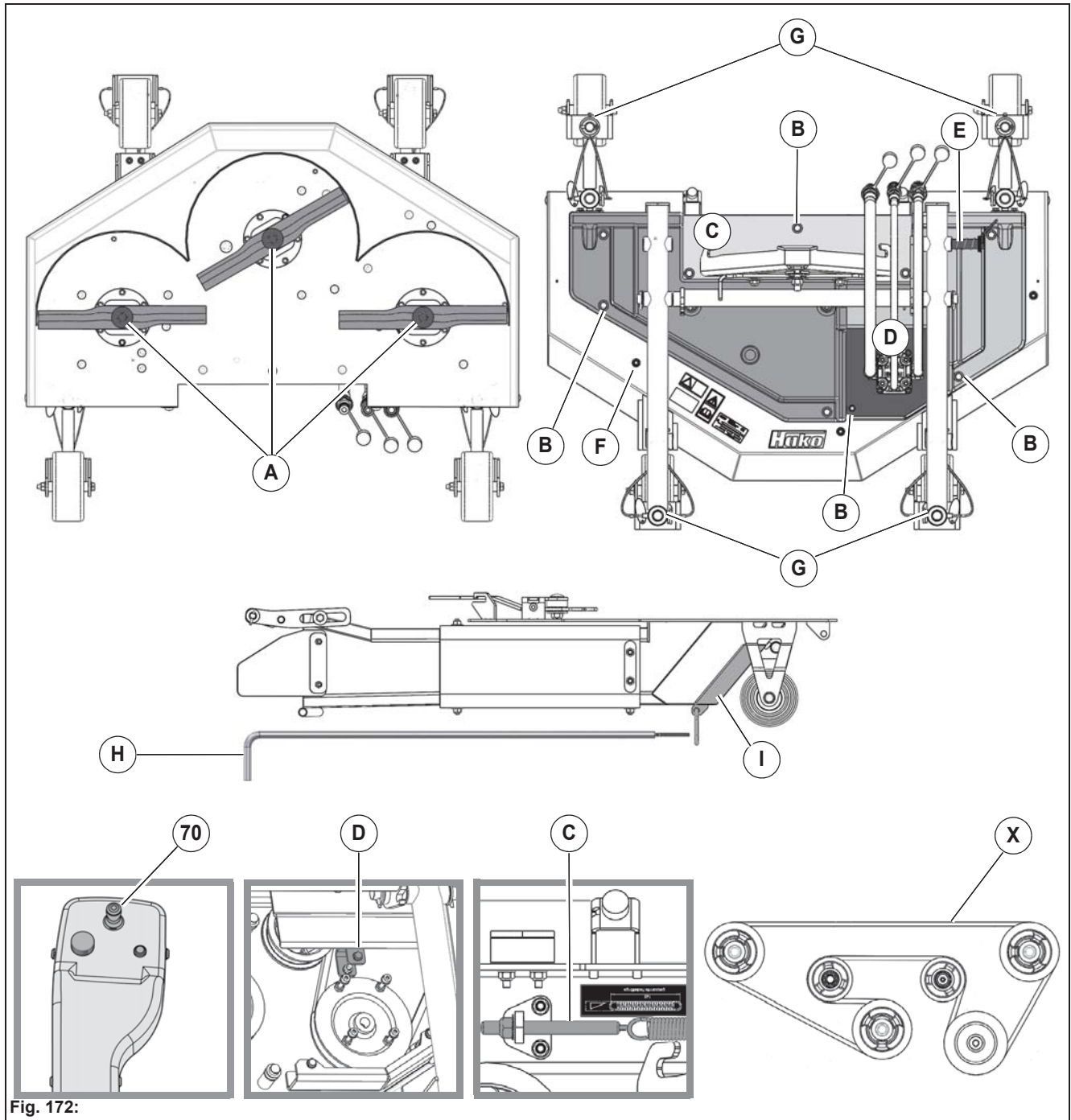

Fig. 172:

Changing mowing blades

1. Place the vehicle on a level surface and hold it with the parking brake. Raise the mower with the joystick **Fig. 172-70**. Switch the engine off and pull out the ignition key.
2. Loosen the screw **Fig. 172-A** and take off the disk and mowing blade.
3. Fit new mowing blade with disk and screw.



Note

Tightening torque of the mowing blades: 120 Nm

Changing the V-belt

1. Place the vehicle on a level surface and hold it with the parking brake. Raise the mower with the joystick **Fig. 172-70**. Switch the engine off and pull out the ignition key.
2. Loosen the screws on the covers **Fig. 172-B** and remove the covers.
3. Relax the tension spring with the screw **Fig. 172-C** and unhook it.
4. Remove the screws of the gearbox holder **Fig. 172-D** and remove the defective V-belt.
5. Insert the new V-belt corresponding to **Fig. 172-X**.
6. Fasten the screws on the gearbox holder.
7. Adjust the clamping screw again corresponding to the clamping length of the label (165 mm).
8. Refit the covers correctly.

Cleaning the mower

1. Place the vehicle on a level surface and hold it with the parking brake. Raise the mower with the joystick **Fig. 172-70**. Switch the engine off and pull out the ignition key.
2. Bring the mower into the cleaning position with the mounting bolt **Fig. 172-E**.
3. Clean the mower from the outside with a water hose or a high-pressure cleaner.
4. Plug the water hose onto the three hose couplings **Fig. 172-F** one after the other and clean with a water hose. Let the mower run for one to two minutes for this.

Cleaning the suction nozzle

1. Place the vehicle on a level surface and hold it with the parking brake. Raise the mower with the joystick **Fig. 172-70**. Switch the engine off and pull out the ignition key.
2. Turn the steering wheel as far as possible to the right.
3. Open the flap **Fig. 172-I** with the lance **Fig. 172-H**. Let the suction fan run for one to two minutes.
4. Lock the flap again with the lance.

Lubrication points

Check the lubrication points weekly.

Grease: Mobilgrease MP

- Bushes of the wheel holders **Fig. 172-G** (4 pieces)

6.2.7 Troubleshooting

Grass remains lying	Remedy	Reference
Outlet clogged	Cleaning the mower	Page 161
Suction nozzle clogged	Cleaning the suction pipe	Page 161
Grass too high or wet	Changing the fixed engine speed Changing the cutting height	Page 159 Page 157
Blades blunt	Grinding the blades	Page 161
Blades do not rotate	Remedy	Reference
V-belt defective	Changing the V-belt	Page 161
Ground irregularities are not compensated for	Remedy	Reference
Mounting plug not fitted as specified	Checking the transport protection device	Page 157
Wheels do not turn	Remedy	Reference
Wheels dirty	Cleaning wheels and hubs	Page 161
Mower runs loud and sounds hard	Remedy	Reference
Checking the blade bearings	Balancing the blades	
Gearbox defective or without oil	Checking the gearbox	

6.2.8 Accessories

Your authorised Hako dealer is available to you at any time to answer questions on accessories for the lawn mowing system.

6.3 Sweeping system

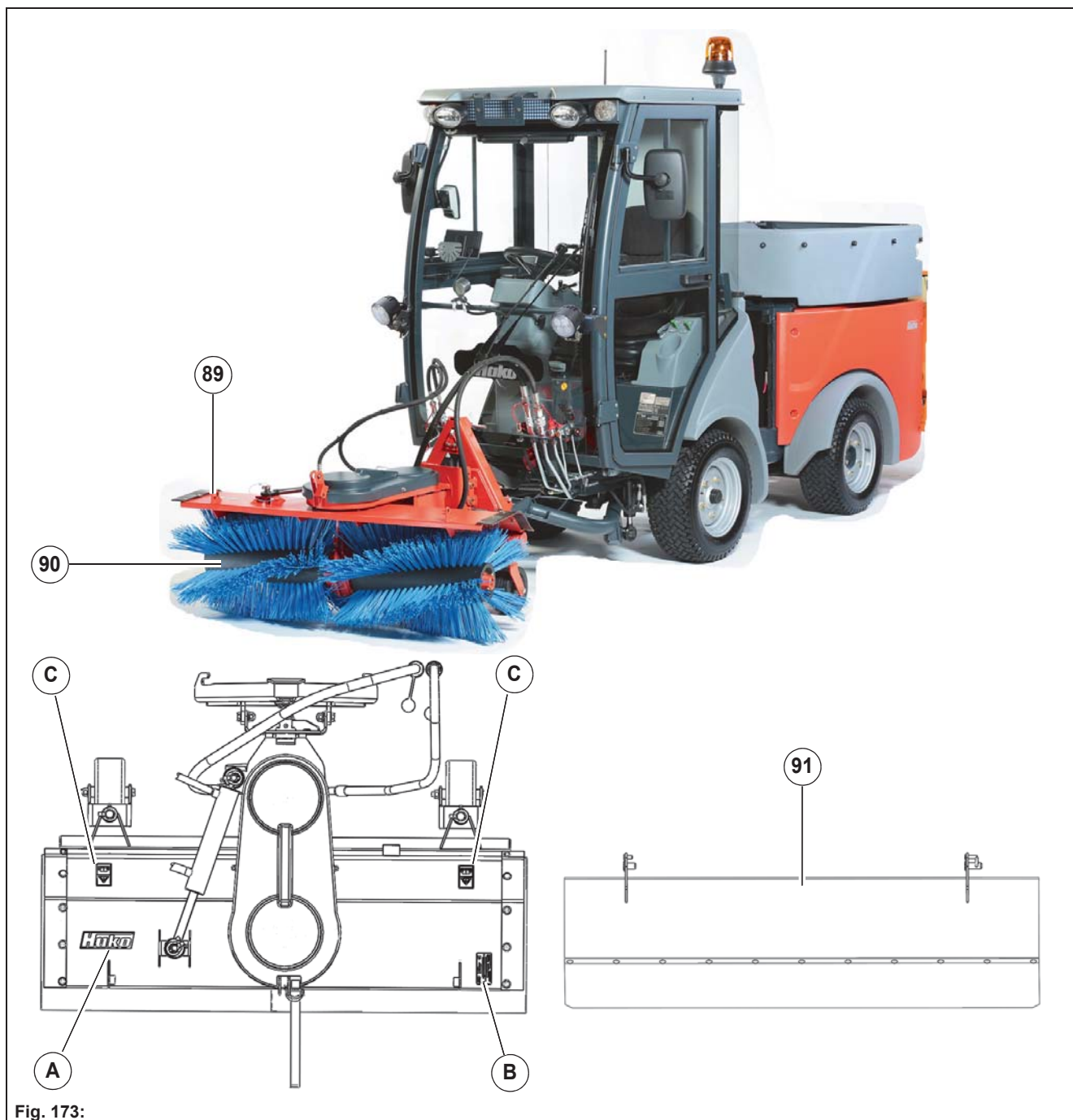

Fig. 173:

Item	Designation	Type
89	Front sweeping machine 130 cm	590110
90	Sweeping roller	5902
91	Spray shield	590210

6.3.1 Labels on the unit

Hako logo

The Hako logo **Fig. 173-A** is located on the right side of the front sweeping machine.

Type plate

The type plate **Fig. 173-B** is located on the left side of the front sweeping machine.

Label – Read operating manual

The Read operating manual label **Fig. 173-C** is located on the left and right side of the front sweeping machine.

6.3.2 Sweeping system safety instructions



Warning

- You must consult Hako before attaching other attachments not approved by Hako!
- The labels attached to the vehicle provide important information for safe operation. Renew labels that are no longer legible or present.
- Spare parts must be original spare parts to guarantee safety.
- Adopt measures against erroneous starting and unwanted movement. Pull out the ignition key.
- Thorough and frequent cleaning is especially important after sweeping material containing salt during snow clearing.
- When sweeping with the front sweeping machine, small stones or other parts in the snow can be thrown out by the rotating brushes. Check the secure seating of the sweeping brushes before every sweeping operation. Secure the front sweeping machine against rolling away when mounting it.
- Check the secure seating of the sweeping brushes before every sweeping operation.
- Modifying the safety equipment is not permitted!
- Secure the front sweeping machine against rolling away when mounting it.

Environmental protection

- Ensure safe and environment-conserving disposal of operating and auxiliary materials. Take up escaping or spilled operating materials in suitable containers and dispose of them in an environmentally friendly manner.

6.3.3 Mounting

Mounting the front sweeping machine

1. Place the vehicle on a level surface and hold it with the parking brake.
2. Unlock the locking hook **Fig. 174-A** and locking rod **Fig. 174-B** on the coupling triangle.
3. Align the front sweeping machine **Fig. 174-92** centrally and in alignment with the coupling triangle.
4. Raise the front tool carrier **Fig. 174-12** with the joystick **Fig. 174-70** and attach the front sweeping machine.
5. Lock the front sweeping machine with locking hook and locking rod.
6. Close the valve **Fig. 174-J** for the suction mouth lift system.
7. Make the connections.
 - Front sweeping machine hydraulic motors – return = **Fig. 174-H**
 - Front sweeping machine hydraulic motors – supply = **Fig. 174-I**
 - Swivelling front sweeping machine – supply = **Fig. 174-D**
 - Swivelling front sweeping machine – return = **Fig. 174-E**
 - Coding plug X 63 = **Fig. 174-K**

Dismantling is in the reverse order.

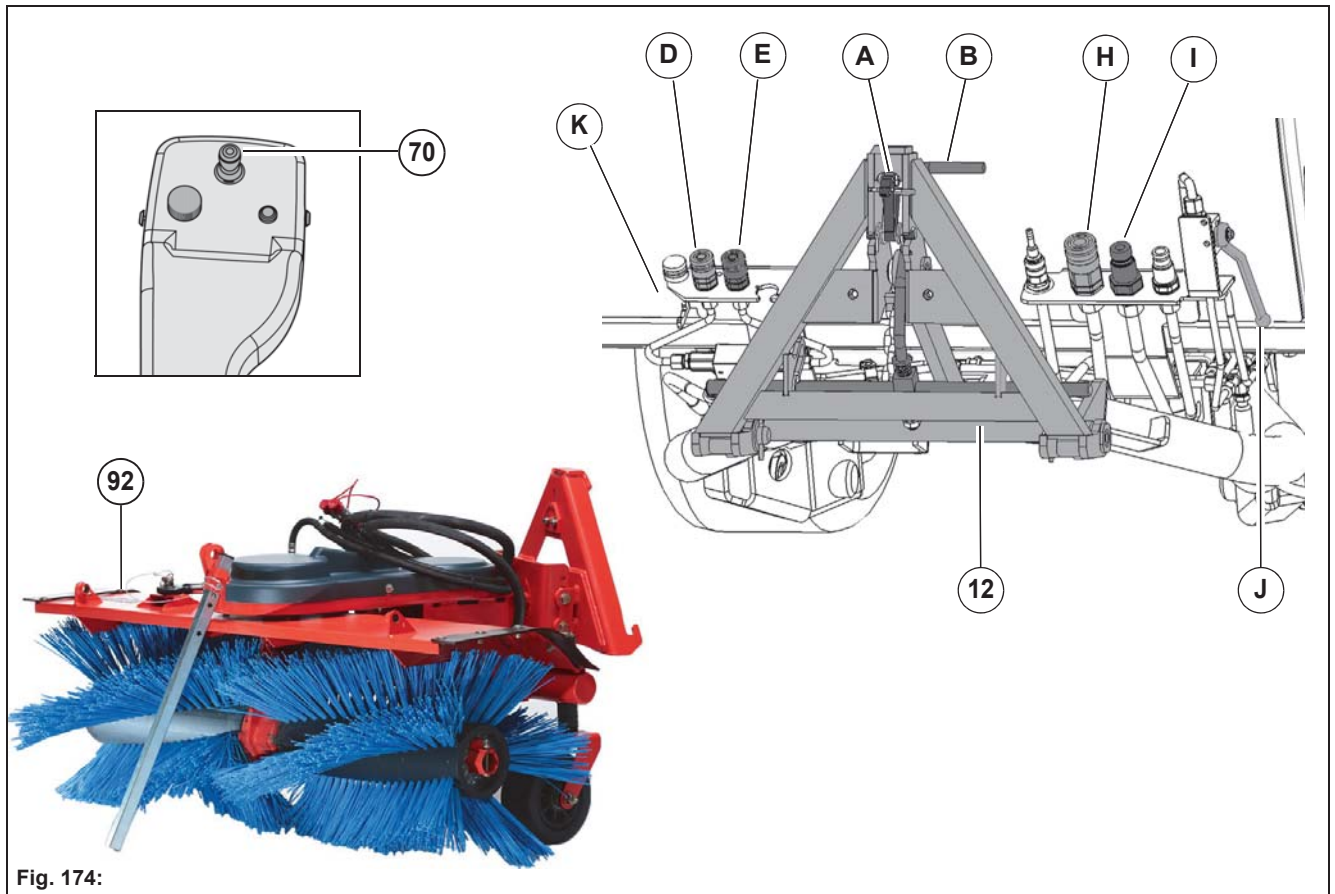

Fig. 174:

6.3.4 Operation

Check-list – Before start-up of the sweeping system

No.	Description	Reference
1	Checking the suction mouth lift system	Page 134
2	Checking the front tool carrier	Page 134
3	Checking the sweeping level	Page 169
4	Mounting the spray shield (summer operation)	Page 166
5	Setting the speed	Page 166
6	Adjusting the sweeping direction	Page 166

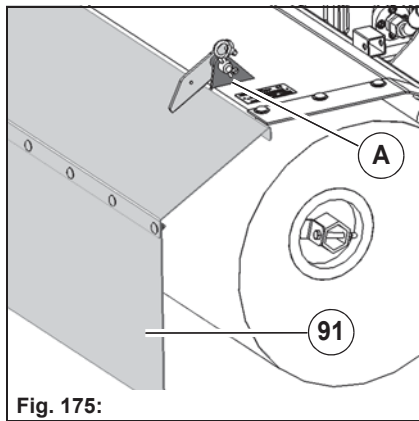

Fig. 175:

Mounting the spray shield

For summer operation set the spray shield **Fig. 175-91** on the holders **Fig. 175-A** of the front sweeping machine and secure with bolts and split-pins.

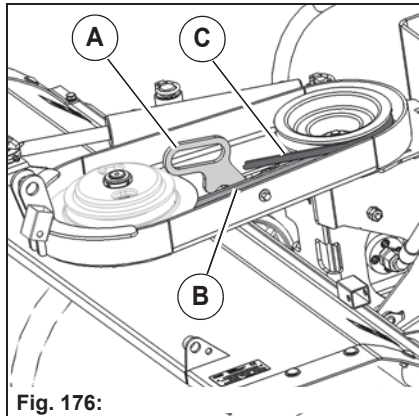

Fig. 176:

Setting the speed

The brush speed of the front sweeping machine can be adapted to the working conditions with the two-stage belt drive. The V-belt can be loosened by moving the handle **Fig. 176-A** so that it can be placed effortlessly in another stage. The speed can be further adapted with the switch for the fixed engine speed, see page 168.

- Summer operation: Stage **Fig. 176-B** (low speed)
- Winter operation: Stage **Fig. 176-C** (high speed)

Use a snow blade or a rotary snow plough in greater depths of snow.

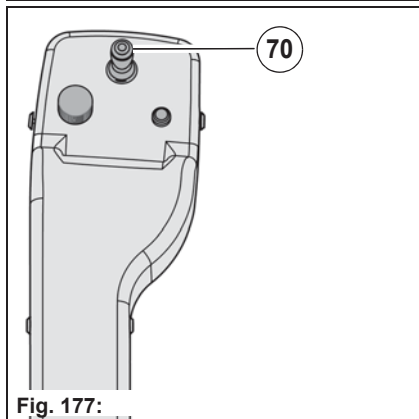

Fig. 177:

Adjusting the sweeping direction

Set the sweeping direction of the front sweeping machine with the joystick **Fig. 177-70**.

- Joystick to the left: The front sweeping machine swivels to the left.
- Joystick to the right: The front sweeping machine swivels to the right.

Checklist – Sweeping

No.	Description	Reference
1	Driving to the work site	Page 167
2	Switching sweeping on	Page 167
3	Setting the fixed engine speed	Page 168
4	Starting sweeping	Page 168

Driving to the work site

1. Bring the front sweeping machine into the transport position, see page 157.
2. Start the vehicle with the ignition switch **Fig. 178-76**.
3. As required, switch on the dipped headlights **Fig. 178-55**, working light **Fig. 178-56** and rotating beacon **Fig. 178-60**.
4. Drive to the work site in the transport mode. The front sweeping machine must be in the upper end position for the transport mode. Push the joystick **Fig. 179-70** back for this purpose.

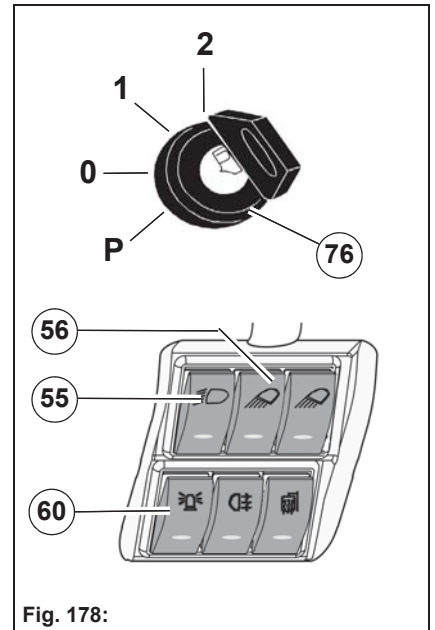

Fig. 178:

Switching sweeping on

1. Switch on the work mode with the Hako button **Fig. 179-71**. The accelerator pedals must be in the neutral position. The coupling triangle work mode symbol appears in the multifunction display **Fig. 179-A**.
2. Switch on the hydraulic circuit. Switch the hydraulic oil circuit I for front attachments on with the turn-push knob **Fig. 179-69**.
3. Lower the front sweeping machine with the joystick **Fig. 179-70**. The following functions are activated:
 - The front sweeping machine is lowered (floating position).
 - The sweeping drive is switched on.
 - The sweeping roller speed is activated.

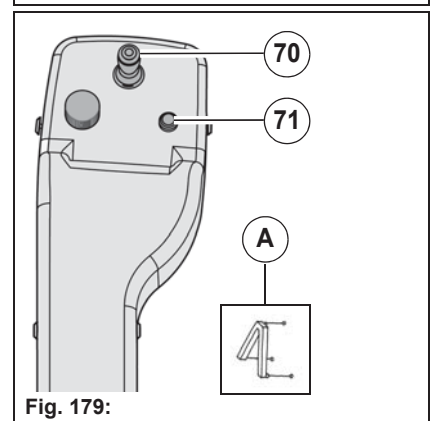

Fig. 179:

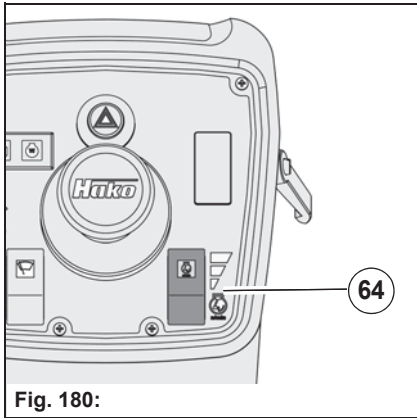

Fig. 180:

Setting the fixed engine speed

The fixed engine speed is set with the switch **Fig. 180-64**. Set the speed according to the requirements.

The speed must be set so that a centrifuging effect is achieved.

Stage	rpm	Use
1 – ECO	1900	At low load
2 – Standard	2250	For medium load
3 – Maximum	2630	For high load

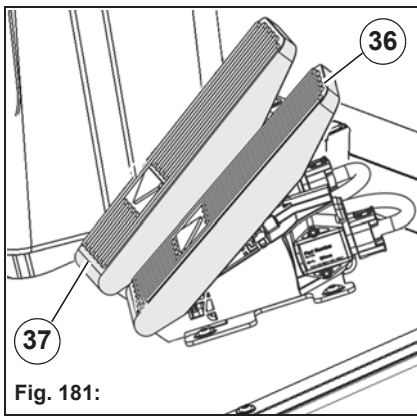

Fig. 181:

Starting sweeping

The accelerator pedal **Fig. 181-36** is used for continuously changing the speed for driving forwards.

The accelerator pedal **Fig. 181-37** is used for continuously changing the speed for reversing.

Push the accelerator pedal down slowly until the vehicle starts, the speed is increased further by pressing on the pedal.

Slowing down or braking the vehicle: Slowly reduce the pressure on the accelerator pedal, the vehicle slows down or stops.

The vehicle speed in the:

- transport mode is 0 to 25 km/h,
- work mode 15/20/25 km/h according to selected engine speed.

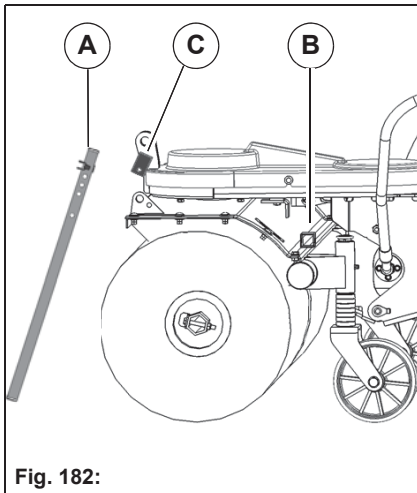

Fig. 182:

Setting down the front sweeping machine

Set the front sweeping machine so that the bristles of the sweeping roller do not touch the ground.

1. Loosen the support **Fig. 182-A** from the rear holder **Fig. 182-B** of the front sweeping machine by removing the bolt and split-pin.
2. Insert the support in the front holder **Fig. 182-C**.
3. Secure with bolt and split pin when the required supporting height is reached.

6.3.5 Technical data

Front sweeping machine	Unit	
Length	mm	900
Width	mm	1300/1500
Height	mm	673
Sweeping width	mm	1300/1500
Weight	kg	109
Sweeping roller diameter	mm	420

6.3.6 Maintenance

Maintenance plan

Daily
<ul style="list-style-type: none"> • Checking wear and damage to the front sweeping machine
Weekly
<ul style="list-style-type: none"> • Checking lubrication points

Maintenance work

Changing the sweeping roller

1. Place the vehicle on a level surface and hold it with the parking brake. Raise the front sweeping machine with the joystick **Fig. 179-70**. Switch the engine off and pull out the ignition key.
 2. The sweeping rollers are fastened to the support tube **Fig. 183-A** with screw **Fig. 183-B**, washer and angle plate **Fig. 183-C**. Loosen the screw and take everything off.
 3. Fit a new sweeping roller with screw, washer and angle plate.
- You must readjust the sweeping level after changing the sweeping rollers.

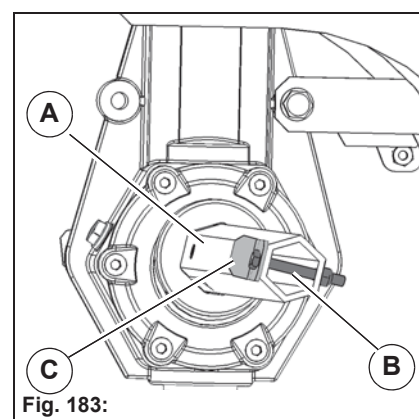

Checking the sweeping level

Check the sweeping rollers daily. Change worn sweeping rollers.

1. Place the vehicle on a level surface and hold it with the parking brake. Raise the front sweeping machine with the joystick **Fig. 179-70**.
2. Remove the split-pin **Fig. 184-A** from the bolt of the wheel fork and withdraw the supporting wheels **Fig. 184-B** downwards.
3. Adjust the sweeping level with the washers **Fig. 184-C** on both supporting wheels. For optimum sweeping effect the bristles should press over the ground approx. 20 cm.
4. Reattach the supporting wheels and secure them with split-pins.
5. Check the sweeping level on dust and chalk.

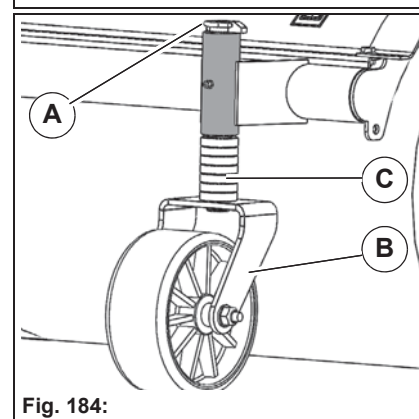

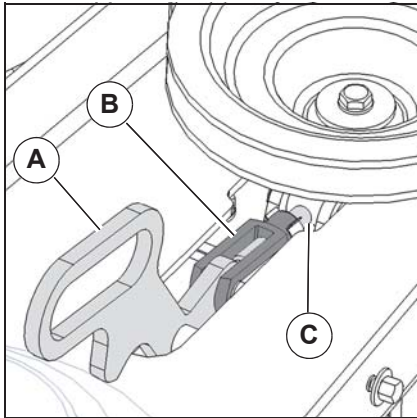

Checking the V-belt tension

1. Loosen the screws and remove the cover.
2. Pull up the handle **Fig. 186-A** for adjusting the V-belt.
3. Open the locking clamp and unhook the fork head **Fig. 186-B**.
4. Adjust the V-belt tension with the bolt **Fig. 186-C**.
5. Hook in the fork head, close the locking clamp and push the handle back down.

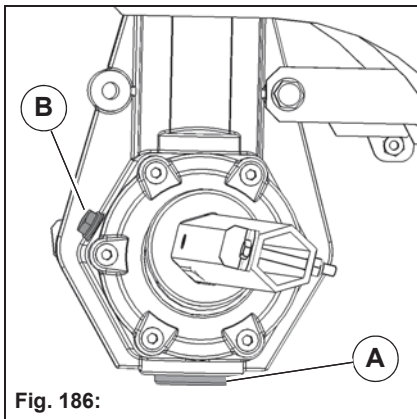

Fig. 186:

Changing the gearbox oil

Check and if necessary top up the oil level in the gearbox. An oil change is necessary after 500 operating hours (at the latest after two years).

1. Place a suitable collecting pan under the drain screw **Fig. 186-A**.
2. Unscrew the drain screw and drain off the gearbox oil completely.
3. Insert the drain screw with new seal.
4. Unscrew the filling screw **Fig. 186-B** and fill with SAE 80W90 gearbox oil. Filling volume = 0.4 litres.
5. Insert the filling screw with new seal.

Lubrication points

Check the lubrication points weekly.

Grease: Mobilgrease MP

- Left/right supporting wheels (2 pcs.) **Fig. 187-A**
- Supporting tube on the coupling triangle (1 pc.) **Fig. 187-B**
- Rod eyes on the hydraulic cylinder (2 pcs.) **Fig. 187-C**
- Central drive shaft (2 pcs.) **Fig. 187-D**

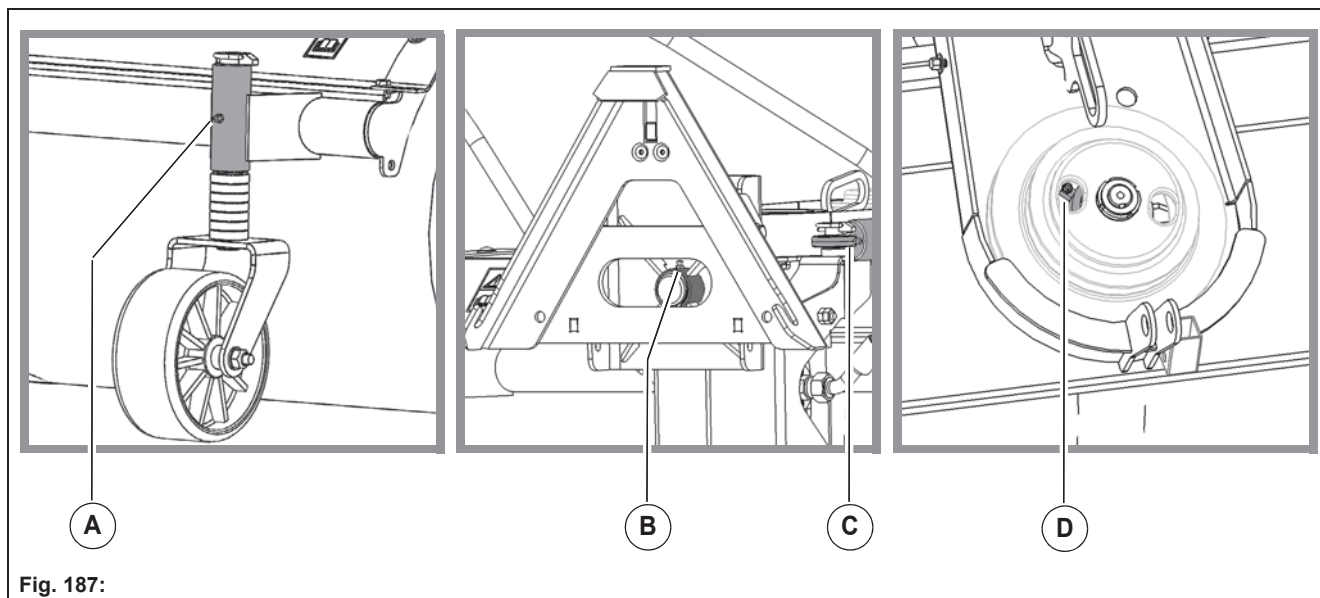

6.3.7 Troubleshooting

Sweeping performance is bad	Remedy	Reference
Speed of the sweeping brush too low	Increasing the fixed engine speed	Page 168
Sweeping level out of adjustment	Adjusting the sweeping level	Page 169
V-belt slips	Tensioning the V-belt	Page 170
Sweeping roller worn	Changing the sweeping roller	Page 169

6.3.8 Accessories

Your authorised Hako dealer is available to you at any time to answer questions on accessories for the sweeping system.

6.4 Snow clearing system



Fig. 188:

Item	Designation	Type
92	Snow blade 135 cm	570130
93	Loading platform	143810
94	Spreader	577600

6.4.1 Labels on the unit

Hako logo

A Hako logo **Fig. 188-A** is located on the snow blade, the loading platform and the spreader.

Type plate

A type plate **Fig. 188-B** is located on the snow blade, the loading platform and the spreader.

Label – Read operating manual

The Read operating manual label **Fig. 188-C** is located on the snow blade, the loading platform and the spreader.

6.4.2 Snow clearing system safety instructions



Warning

- You must consult Hako before attaching other attachments not approved by Hako!
- The labels attached to the vehicle provide important information for safe operation. Renew labels that are no longer legible or present.
- Spare parts must be original spare parts to guarantee safety.
- Adopt measures against erroneous starting and unwanted movement. Pull out the ignition key.
- Thorough and frequent cleaning is especially important after sweeping material containing salt.
- Modifying the safety equipment is not permitted!
- Use winter operation only in connection with an uncoded attachment. In winter operation the front lift system is not limited downwards. There is a risk of an accident on unintended lowering of the attachment.

6.4.3 Mounting

Mounting the snow blade

1. Place the vehicle on a level surface and hold it with the parking brake. Switch the engine off and pull out the ignition key.
 2. Unlock the locking hook **Fig. 189-A** and locking rod **Fig. 189-B** on the front tool carrier **Fig. 189-12**.
 3. Align the snow blade **Fig. 189-92** centrally and in alignment with the front tool carrier.
 4. Raise the snow blade with the joystick **Fig. 189-70** up into the end position.
 5. Lock the snow blade with the locking hook and locking rod.
 6. Close the valve **Fig. 189-C** for the suction mouth lift system.
 7. Make the connections.
 - Swivel snow blade – supply = **Fig. 189-D**
 - Swivel snow blade – return = **Fig. 189-E**
 - Coding plug X 63 = **Fig. 189-F**
- Dismantling is in the reverse order.

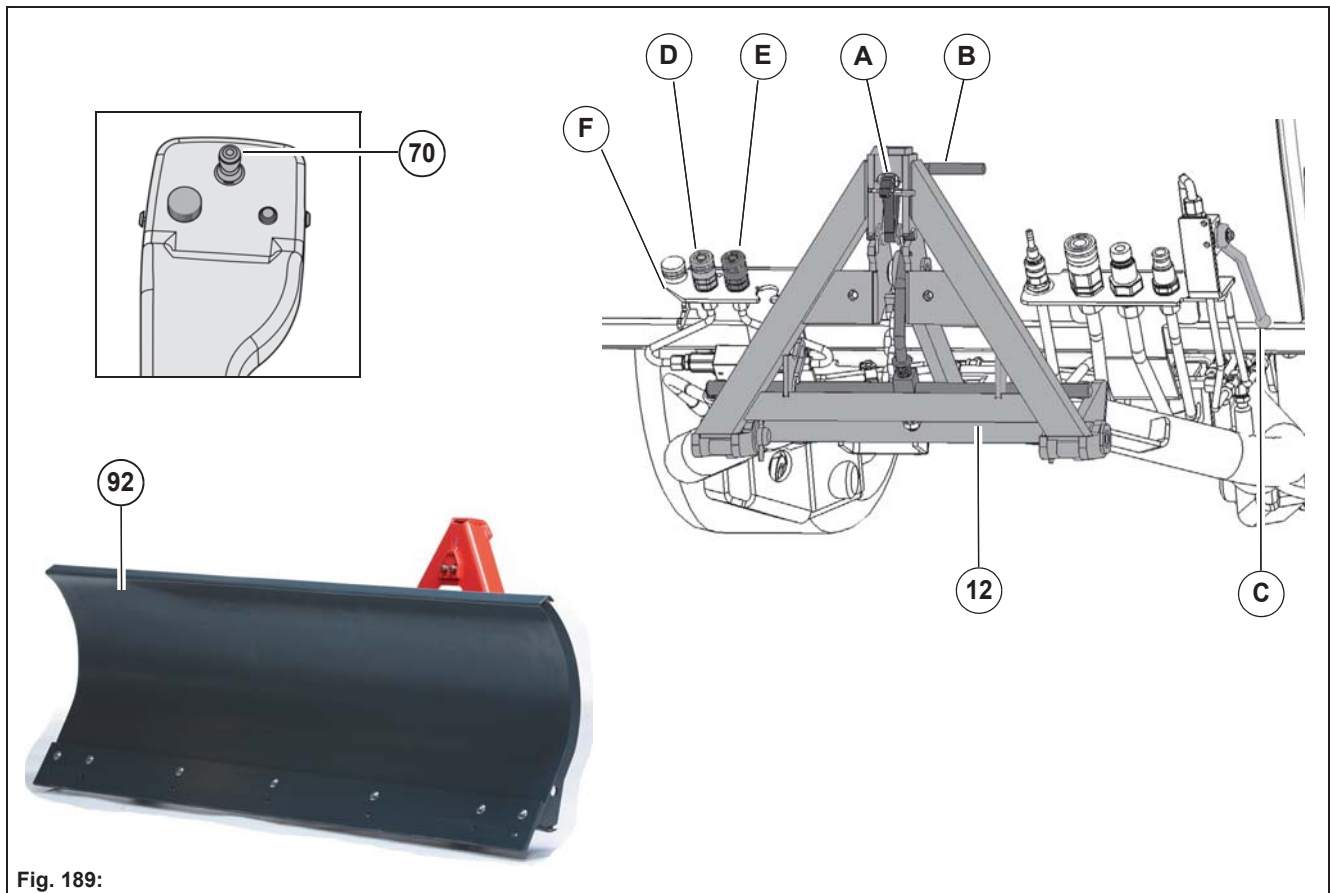



Fig. 189:

Mounting the loading platform

1. Place the vehicle on a level surface and hold it with the parking brake.
2. Unlock the lever **Fig. 190-A** of the trolley **Fig. 190-97** and swing it into the upper position.
3. Hold the lever **Fig. 190-A** in the upper position with one hand. With your other hand plug the mounting bolt **Fig. 190-B** on the Citymaster 650.

	<p>Danger Risk of injury! The lever Fig. 190-A can swing over.</p>
---	--

4. Unlock the sledge **Fig. 190-C** with the lever and push it into the front position.

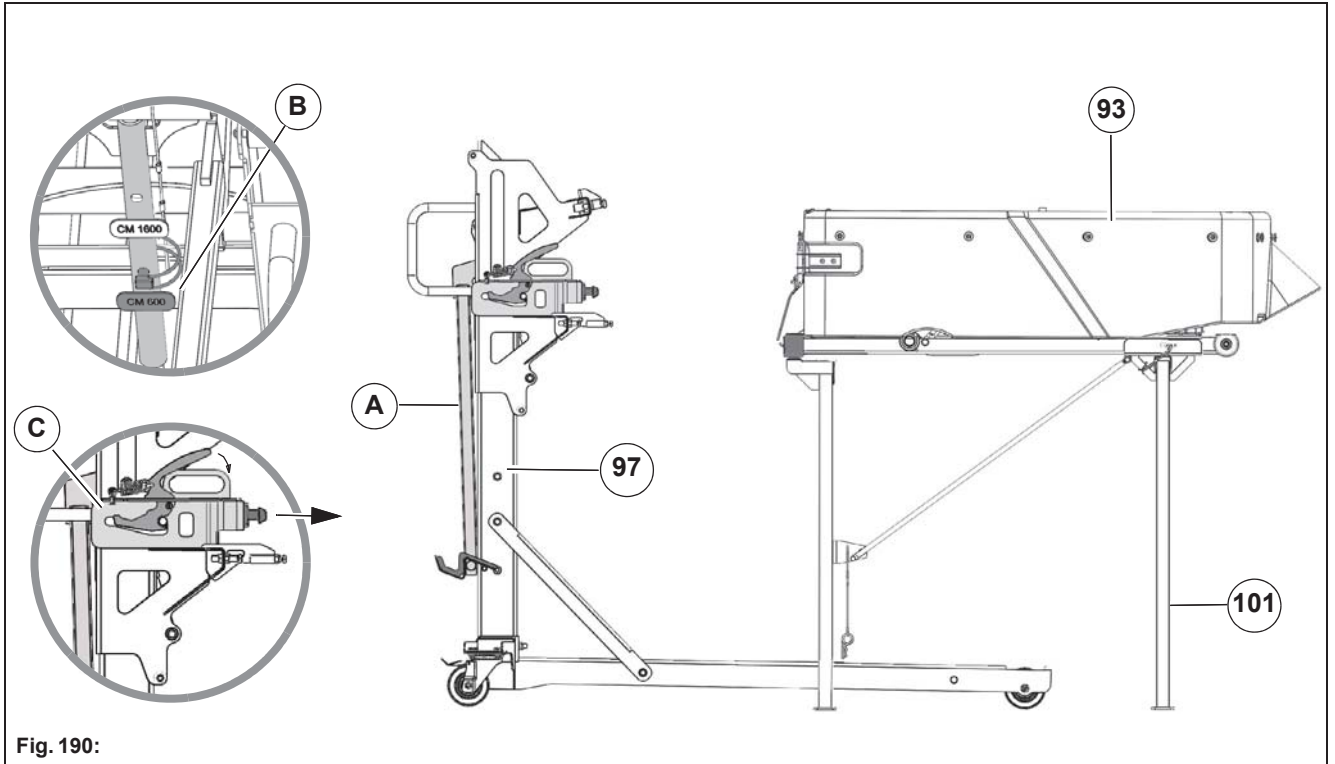



Fig. 190:

Continued – Mounting the loading platform

	<p>Danger Risk of injury due to tilting over! Make sure that the cross strut Fig. 191-G has been inserted when transporting the loading platform on the supports Fig. 191-101. Secure the supports with bolts and splints.</p>
---	---

5. Push the trolley with the lower positioning aid **Fig. 191-B** against the fixed bearings **Fig. 191-D** of the loading platform. The screw **Fig. 191-C** must be adjusted to 26 mm!
6. Carefully lower the lever **Fig. 191-A** of the trolley and make sure that the locking pins **Fig. 191-E** sit in the holders **Fig. 191-F** of the loading platform. Lock the lever **Fig. 191-A**.
7. Remove the supports **Fig. 191-101**. To do this, pull out the split pins and the bolts.

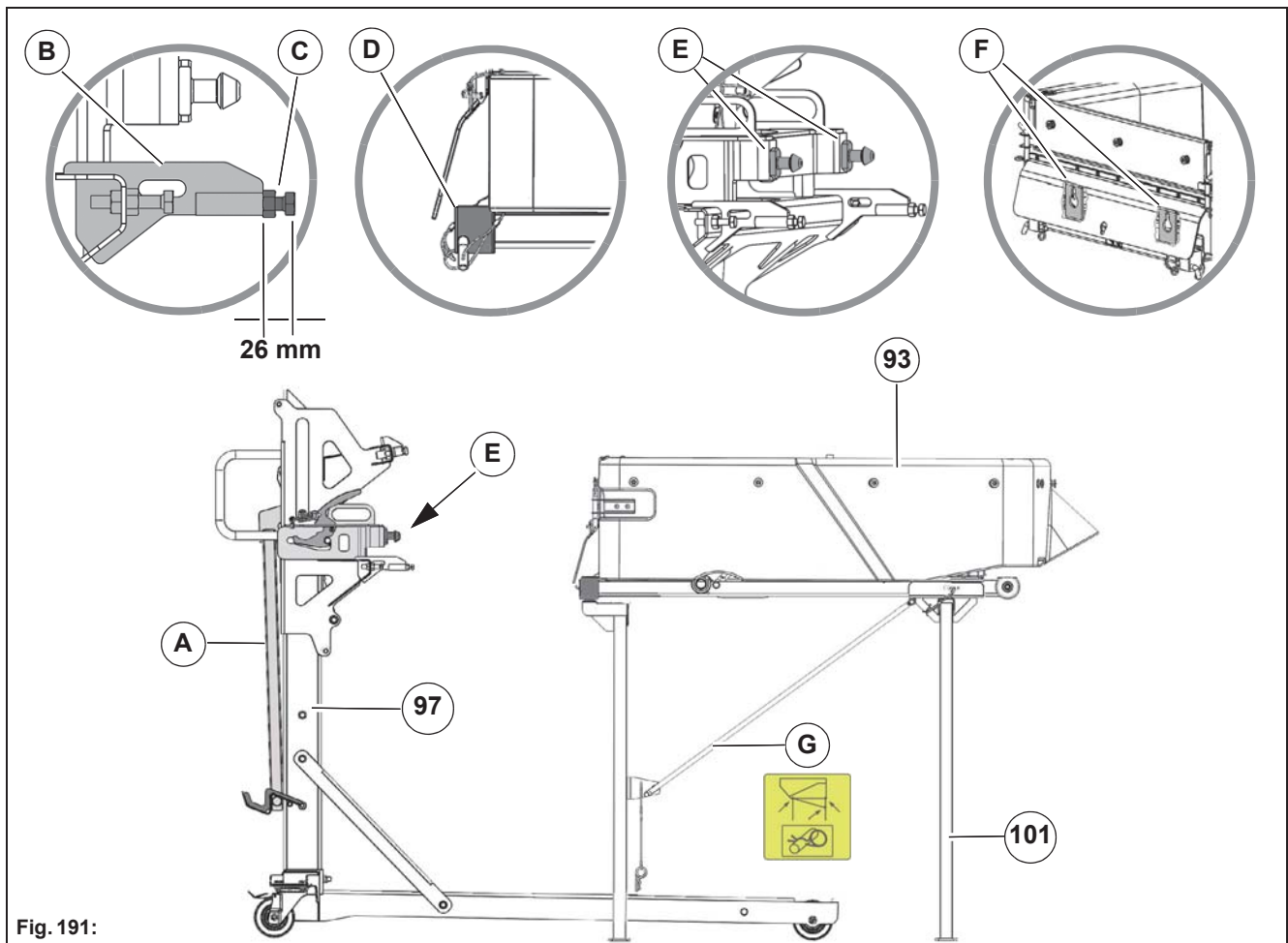

Fig. 191:

Continued – Mounting the loading platform

8. Align the loading platform to the rear wagon:

Procedure:

- Position the loading platform over the rear wagon and check the gap size **Fig. 192-X** with 5-10 mm. If necessary, correct with the adjusting screw **Fig. 192-A**.
- Push the rollers of the loading platform up into the pockets **Fig. 192-B** of the rear wagon.
- The holders **Fig. 192-C** of the loading platform and the holders **Fig. 192-D** of the rear wagon must be in alignment.

9. Unlock the lever **Fig. 192-E** of the trolley and lift the trolley carefully. Let the loading platform down slowly! Withdraw the trolley.

10. Secure the loading platform with bolts and splints.

11. Make the connections.

- Loading platform raising/lowering – supply = **Fig. 192-F**
- Loading platform raising/lowering – return = **Fig. 192-G**

Dismantling is in the reverse order.

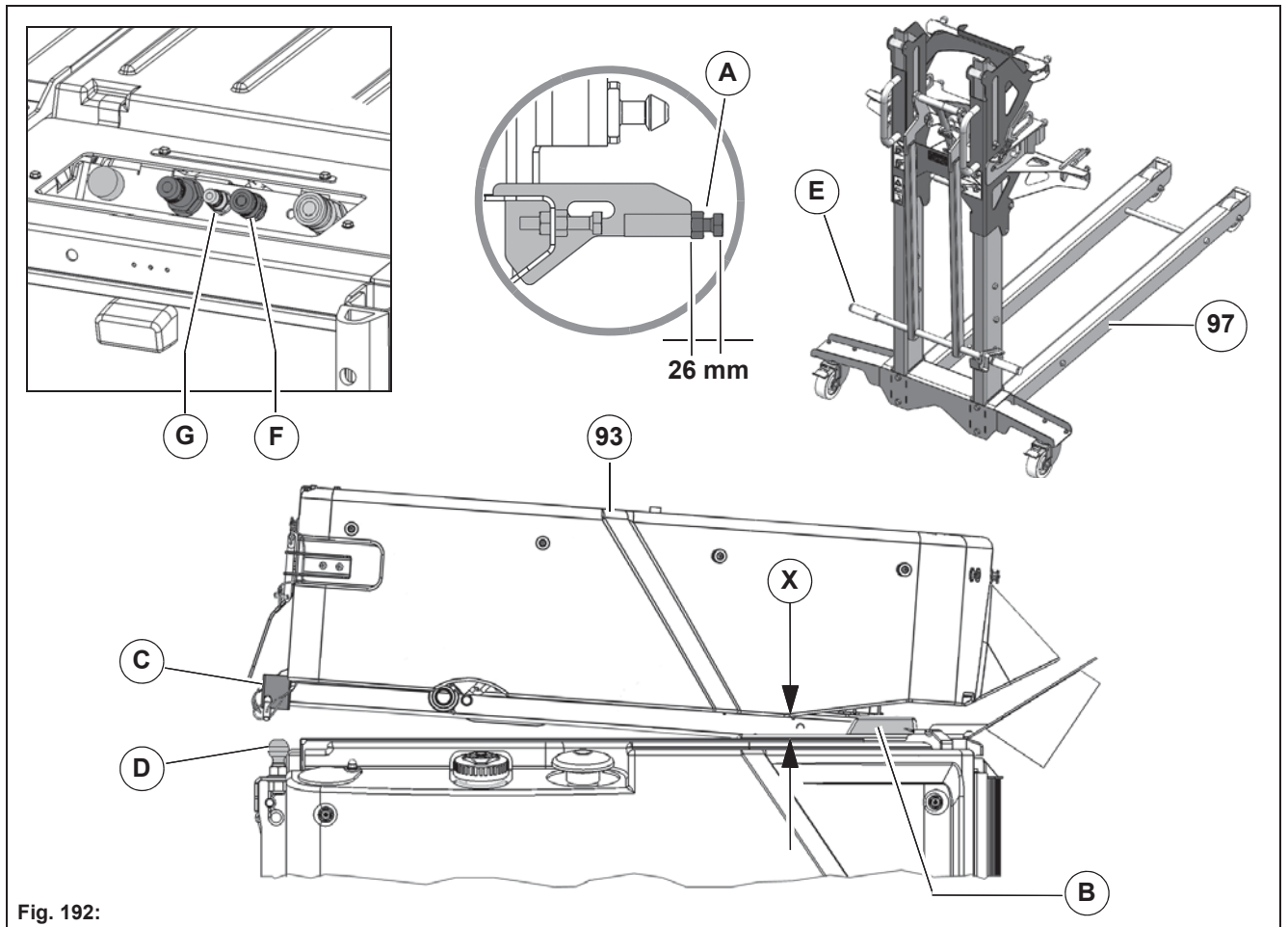

Fig. 192:

Mounting the spreader

1. Place the vehicle on a level surface and hold it with the parking brake. Switch the engine off and pull out the ignition key.
 2. Move the spreader with mounting wagon carefully to the tail of the vehicle and align it.
 3. Make the connections.
 - Spreader roller hydraulic motor – supply **Fig. 193-B**
 - Spreader roller hydraulic motor – return **Fig. 193-E**
 - Spreading disk hydraulic motor – supply **Fig. 193-C**
 - Spreading disk hydraulic motor – return **Fig. 193-D**
 - X65 – 7-pin socket for lighting **Fig. 193-G**
 - X67 – 7-pin socket for spreader **Fig. 193-H**
 - X68 – 7-pin socket for spreader **Fig. 193-I**
 4. With both cranks **Fig. 193-J** of the trolley lower the spreader evenly onto the holding points **Fig. 193-F** of the vehicle tail end and secure with bolts.
 5. Remove the trolley.
- Dismantling is in the reverse order.
 An optional control cable is required for the socket X68.
 The optional odometer is required for the distance-dependent spreading function.

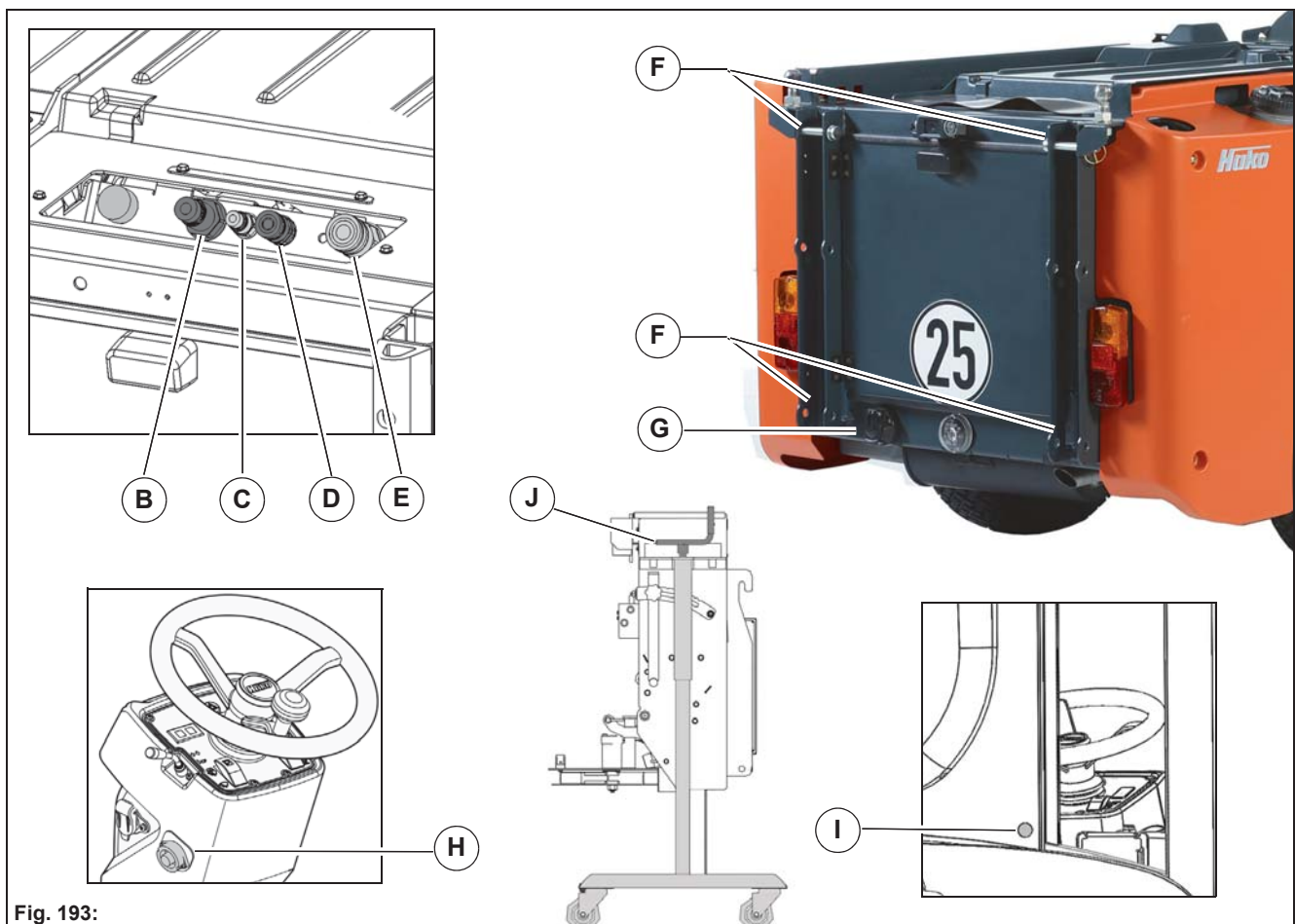

Fig. 193:

6.4.4 Operation

Checklist – Before start-up of the snow clearing system

No.	Description	Reference
1	Checking the suction mouth lift system	Page 134
2	Checking the front tool carrier	Page 134
3	Switching winter operation on	Page 179
4	Adjusting the attack angle	Page 179
5	Loading the loading platform and spreader	Page 179
6	Adjusting the spreading volume	Page 179
7	Adjusting the spreading width	Page 179

Switching winter operation on

Select the C menu in the multifunction display with the turn-push knob **Fig. 194-69** and activate winter operation in the menu item E, see page 42. The Winter service information symbol **Fig. 194-A** appears in the multifunction display.



Warning

Use winter operation only in connection with an uncoded attachment. In winter operation the front lift system is not limited downwards. There is a risk of an accident on unintended lowering of the attachment.

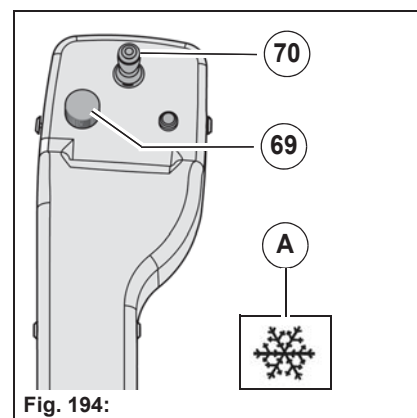

Fig. 194:

Adjusting the attack angle

Adjust the attack angle with the joystick **Fig. 194-70**.

- Joystick to the left: The front attachment swivels to the left
- Joystick to the right: The front attachment swivels to the right

Loading the loading platform

Note when loading the loading platform:

- Load on the loading platform (bulk goods) with spreader attached maximum 150 kg
- Load on the loading platform (bulk goods) with spreader not attached maximum 400 kg
- Load on the loading platform (piece goods) with spreader attached: maximum 100 kg

Filling height of the loading platform, see mark **Fig. 195-A**. Load capacity of the tie-down eyes **Fig. 195-B**: maximum 100 daN. You can use the separating board **Fig. 195-C** for different materials.

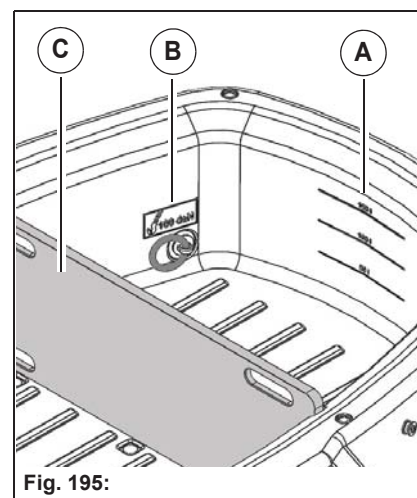

Fig. 195:

Loading the spreader

Different specific weights arise according to the condition of the spread material (wet or dry). Check the specific weight of the spread material before filling.

Payload of the spreader, see operating manual of the spreader.

Adjusting the spread volume

Adjusting the spread volume, see operating manual of the spreader.

Adjusting the spreading width

The spreading width depends on the condition of the spread material and the speed of the spreading disk. The more coarse grained the spread material is, the larger is the possible spreading width.

Adjusting the spreading width, see operating manual of the spreader.

Check-list – Snow clearing

No.	Description	Reference
1	Driving to the work site	Page 180
2	Switching snow clearing on	Page 180
3	Setting the fixed engine speed	Page 181
4	Starting snow clearing	Page 181

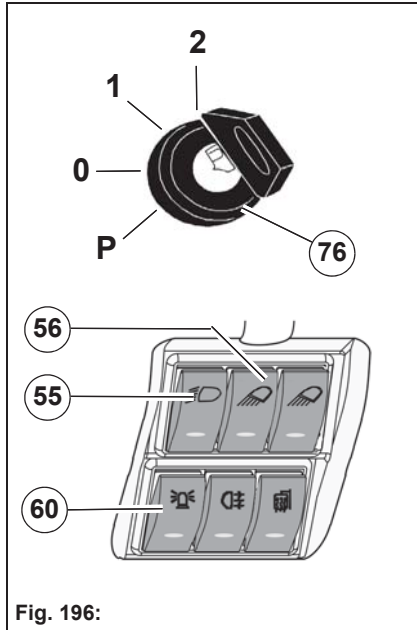

Driving to the work site

1. Bring the snow blade into the transport position, see page 157.
2. Start the vehicle with the ignition switch **Fig. 196-76**.
3. As required, switch on the dipped headlights **Fig. 196-55**, working light **Fig. 196-56** and rotating beacon **Fig. 196-60**.
4. Drive to the work site in the transport mode. The front attachment must be in the upper end position for the transport mode. Push the joystick **Fig. 197-70** back for this purpose.

Switching snow clearing on

1. With the joystick **Fig. 197-70** lower the snow blade into the floating position.
2. Start snow clearing in the transport mode.



Note

For snow clearing with the front sweeping machine, the procedure is similar to that described on page 163.

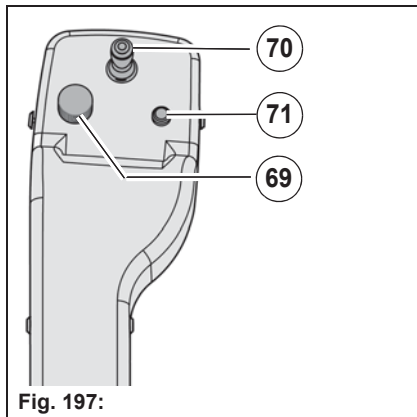

Switching spreading on

1. Switch the hydraulic oil circuit II for rear attachments on with the turn-push knob **Fig. 197-69**.
2. Start spreading in the transport mode.



Note

Switch the spreader off with a time delay:
 The spreading run-on time can be set between 0 and 4 seconds in the C menu in menu item E (winter operation).
 Spreader fast emptying:
 Spreader fast emptying can be switched on and off in the C menu in menu item E (winter operation).

Setting the fixed engine speed

The fixed engine speed is set with the switch **Fig. 198-64**. Set the speed according to the requirements.

Stage	rpm	Use
1 – ECO	1900	At low load
2 – Standard	2250	For medium load
3 – Maximum	2630	For high load

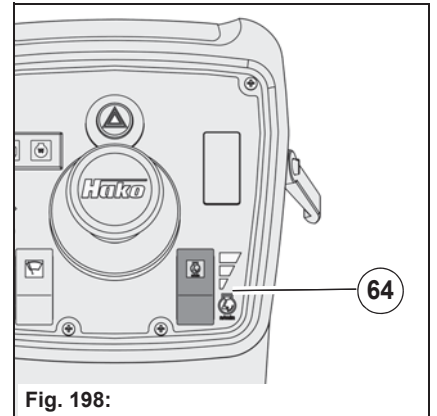

Fig. 198:

Starting snow clearing

The accelerator pedal **Fig. 199-36** is used for continuously changing the speed for driving forwards.

The accelerator pedal **Fig. 199-37** is used for continuously changing the speed for reversing.

Push the accelerator pedal down slowly until the vehicle starts, the speed is increased further by pressing on the pedal.

Slowing down or braking the vehicle: Slowly reduce the pressure on the accelerator pedal, the vehicle slows down or stops.

The vehicle speed in the:

- transport mode is 0 to 25 km/h,
- work mode 15/20/25 km/h according to selected engine speed.

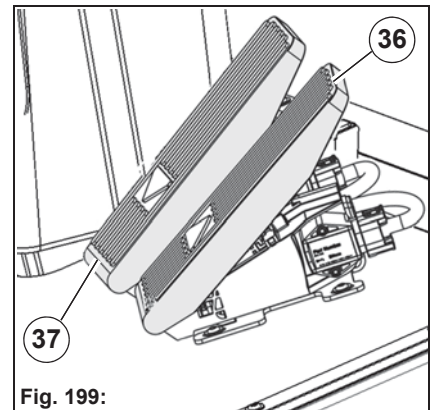

Fig. 199:



Attention

Before you leave the vehicle, the attachment must be lowered to the ground!

6.4.5 Technical data

Snow blade	Unit	
Working width	mm	1350
Share height	mm	450

Loading platform	Unit	
Load on the loading platform (bulk goods) with attached spreader	kg	max. 150
Load on the loading platform (bulk goods) with not attached spreader	kg	max. 400
Load on the loading platform (piece goods) with not attached spreader	kg	max. 100

You will find information on technical data in the operating manual of the spreader.

6.4.6 Maintenance

You will find information about the maintenance plan and maintenance work in the operating manual of the snow blade.

6.4.7 Accessories

Your authorised Hako dealer is available to you at any time to answer questions on accessories for the transport system.

6.5 Transport system



Fig. 200:

Item	Designation	Type
95	Trailer	2516

6.5.1 Labels on the unit

Labels on the unit, see operating manual of the trailer.

6.5.2 Safety instructions

	<p>Danger</p> <ul style="list-style-type: none">• Danger to life in the danger area of the vehicle! Special caution is required in the vicinity of the articulated steering, beneath the raised tipper and in the area between the vehicle and the trailer.• Danger to life due to inadequately secured load! The load must be correctly distributed and fastened on the loading surface.• Risk of injury! Modifying the safety equipment is not permitted!• Risk of accident! Adopt measures against erroneous starting and unwanted movement. Switch the engine off and pull out the ignition key.• Risk of accident! You must consult Hako before attaching other attachments not approved by Hako! <p>Warning</p> <ul style="list-style-type: none">• The transport system may be operated only in connection with the Citymaster 650. The safety regulations for the Citymaster 650 must be complied with absolutely. <p>Caution</p> <ul style="list-style-type: none">• The labels attached to the vehicle provide important information for safe operation. Renew labels that are no longer legible or present.• Spare parts must be original spare parts to guarantee safety.
---	---

6.5.3 Mounting

Mounting the trailer hitch plate (optional)

The trailer hitch plate **Fig. 201-A** is mounted without tools to the tail of the vehicle.

1. Remove the locking pins **Fig. 201-B** of the four bolts **Fig. 201-C** of the trailer hitch plate and withdraw the bolts.
2. Position the trailer hitch plate on the vehicle.
3. Secure the trailer hitch plate with bolts and locking pins to the holding points **Fig. 201-D** of the vehicle tail.

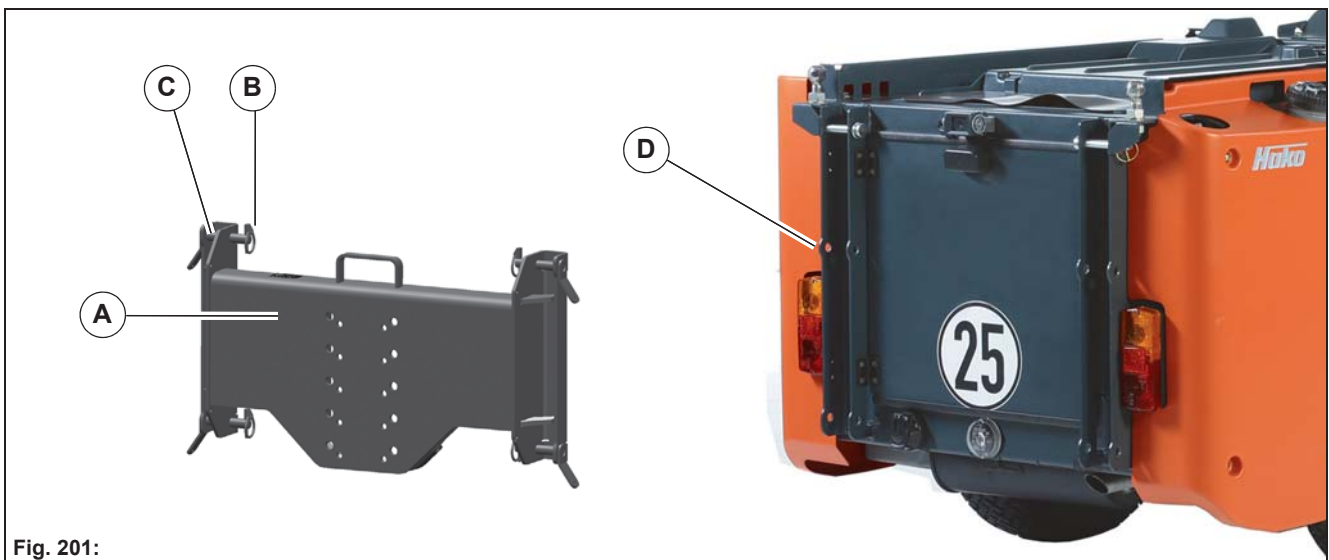



Fig. 201:

Mounting the jaw coupling (optional)

	<p>Note The trailer hitch plate option is required for mounting the jaw coupling.</p>
---	--

Mount the jaw coupling **Fig. 202-A** with the bolts, washers and nuts to the optional trailer hitch plate **Fig. 202-B** in the wanted height. Four setting heights are available.

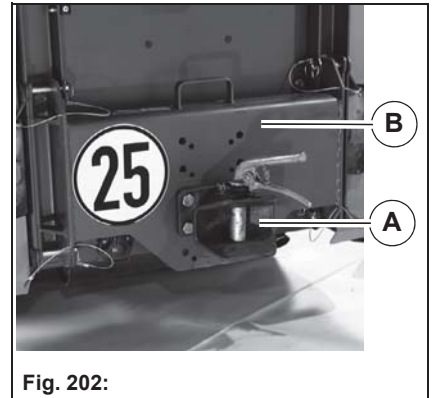



Fig. 202:

Mounting the ball head coupling (optional)

	<p>Note The trailer hitch plate option is required for mounting the ball head coupling.</p>
---	--

Mount the ball head coupling **Fig. 203-A** with the bolts, washers and nuts to the optional trailer hitch plate **Fig. 203-B** in the wanted height. Four setting heights are available.

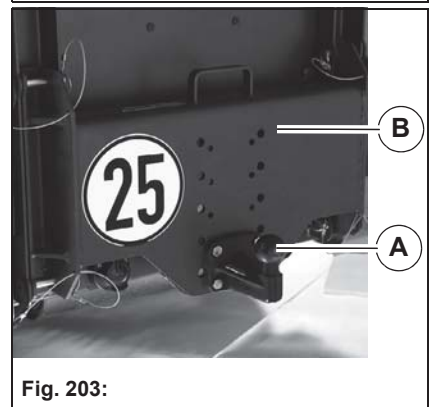



Fig. 203:

Mounting the loading platform

Mounting the loading platform, see page 175.

6.5.4 Operation

	<p>Warning</p> <ul style="list-style-type: none"> • Only put the attachment into service if all instructions stipulated in the operating manual of the attachment manufacturer have been observed. • There is a risk of being crushed at the drawbar. Make sure your hands do not reach into the crushing zone. • Before driving with the vehicle, fully raise and secure the support wheel. The support wheel may be torn off and fly off when driving! • Drive with extreme caution when towing a trailer, since the braking distance is longer than usual! <p>Caution</p> <ul style="list-style-type: none"> • Pay attention to the maximum support load of the trailer coupling. • Also secure trailer with wheel chocks when parking the vehicle on a slope! • Also load the loading surface of the towing vehicle in order to increase traction, reduce the slip between the tyres and the road surface and also reduce tyre wear, and increase general driving safety.
---	--

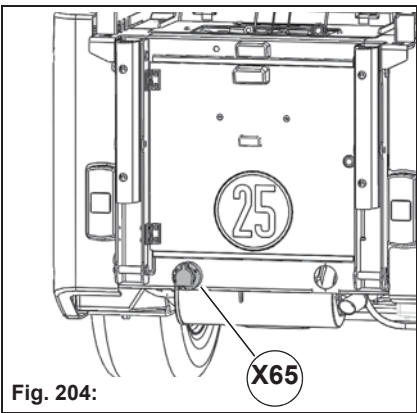

Fig. 204:

Coupling the trailer

1. Apply the parking brake of the trailer.
2. Set the trailer drawbar to the height of the coupling on the towing vehicle.
3. Attach the trailer to the jaw coupling or the ball head coupling.
4. Check the locking of the coupling.
5. Release the height setting of the drawbar or remove the support.
6. Hitch the arrester cable on trailers with overrun brakes.
7. Establish connections and check functioning.
8. Remove the wheel chocks and release the parking brake of the trailer.
9. Check the brakes after moving the vehicle.

Uncoupling the trailer

1. Stop the vehicle and apply the parking brake of the towing vehicle.
2. Apply the parking brake of the trailer.
3. Undo connections.
4. Secure towing drawbar to prevent it from falling down.
5. Open coupling and slowly drive towing vehicle away.

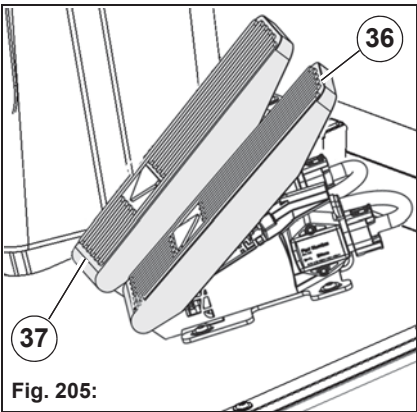

Fig. 205:

Starting transport

The accelerator pedal **Fig. 205-36** is used for continuously changing the speed for driving forwards.

The accelerator pedal **Fig. 205-37** is used for continuously changing the speed for reversing.

Push the accelerator pedal down slowly until the vehicle starts, the speed is increased further by pressing on the pedal.

Slowing down or braking the vehicle: Slowly reduce the pressure on the accelerator pedal, the vehicle slows down or stops.

The vehicle speed in the:

- transport mode is 0 to 25 km/h,
- work mode 15/20/25 km/h according to selected engine speed.

6.5.5 Technical data

Single-axle trailer	Unit	
Length	mm	1800
Width	mm	1000
Height	mm	300
Payload	kg	800
Trailer hitch plate	Unit	
Trailer load braked	kg	1750
Trailer load unbraked	kg	750
Support load	kg	max. 150

Technical data of the loading platform, see page 182.

6.5.6 Maintenance

You will find information about the maintenance plan and maintenance work in the operating manual of the trailer.

6.5.7 Accessories

Your authorised Hako dealer is available to you at any time to answer questions on accessories for the transport system.

6.6 Options

Item	Designation	Type
96	Trolley for sweeping unit	148610
97	Trolley for dirt hopper and loading platform	148602
98	Hand suction hose	144510
99	High-pressure cleaner	113910
100	Trailer hitch plate	350402
101	Supports	148620
102	Hydrant kit	113410
103	Reversing camera	144610
104	Dirt hopper vacuum indicator	843500
105	7-pin control cable	262200
106	Odometer	261910
107	Preparation for radio	261310
108	Lawn tyres	301600
109	Mudguard extension	307110
110	Additional working lights above	261800
111	Reversing light and signal generator	144710
112	Comfort driver's seat	844702
113	Heatable outside mirror	843130
114	Battery isolating switch	261410
115	Cab roof repeat lighting for driving on the right	261810
116	Cab roof repeat lighting for driving on the left	261812
117	Sound insulation package	147300
118	Additional camera	144611
119	Dirt hopper comfort and safety package	147510
120	Adjustable upper link	351200
121	Rear attachment weight holder	344110
122	Ballast weight 17 kg	343900
123	Hydraulic hand pump	147520
124	Front attachment weight holder	344000
125	Path-dependent roller spreader control	577620

**Hako GmbH
Hamburger Str. 209-239
23843 Bad Oldesloe, Germany**

declare in sole responsibility that the following products

**Front sweeping machine – Citymaster 650 Type: 5901
Snow blade – Citymaster 650 Type: 5701
Loading platform – Citymaster 650 Type: 1438
Dirt hopper – Citymaster 650 Type: 1475
Sweeping unit – Citymaster 650 Type: 1476
Fast-changing trolley – Citymaster 650 Type: 1486
Front mower – Citymaster 650 Type: 8101**

on which this declaration is based correspond with the relevant basic safety and health requirements of the EC Directive 2006/42/EC as well as the requirements according to 2014/30/EC.

The following standard(s) and technical specifications was/were referred to for the correct implementation of the safety and health requirements named in the EC Directive:

**EN 12100 for front sweeping machine – Citymaster 650 Type: 5901
EN 12100 for snow blade – Citymaster 650 Type: 5701
EN 12100 for loading platform – Citymaster 650 Type: 1438
EN 13019 for dirt hopper – Citymaster 650 Type: 1475
EN 13019 for sweeping unit – Citymaster 650 Type: 1476
EN 13019 for fast-changing trolley – Citymaster 650 Type: 1486
DIN EN ISO 5395 for front mower – Citymaster 650 Type: 8101**

Name of the authorised person who compiles the technical documents for Hako:
Ludger Lüttel

Bad Oldesloe, 23.01.2018

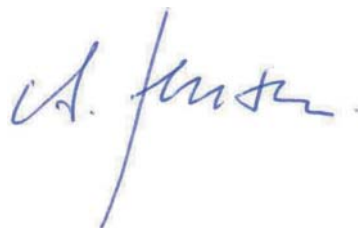

Axel Jensen
Product line manager
Municipal technology

Hako: environmentally friendly from the start

We want to leave a clean earth behind. Protecting resources, the environment and the climate therefore governs all our activities. Independent institutes have confirmed this.

Everywhere and always in your vicinity

Our efficient distribution and service network guarantees short journeys and fast help.

Purchasing, leasing, renting

We offer you a multitude of individual and attractive financing and procurement possibilities.

We are here for you day and night

The Hako stand-by and spare parts express service guarantees the highest availability.



Cleanliness combined with safety
Our machines meet the highest demands.



Blue Competence is an initiative of the VDMA (www.vdma.org). By using the trademark "Blue Competence", we commit ourselves to these twelve Sustainability Guidelines of the Mechanical Engineering Industry: www.bluecompetence.net/about

Hako GmbH
Head Office
Hamburger Str. 209-239
23843 Bad Oldesloe
Germany
Tel. +49(0) 4531-806 0
info@hako.com
www.hako.com